

Axial piston variable pump A15VSO, A15VLO Series 11



- ▶ Sizes 110 to 280
- ▶ Nominal pressure 350bar
- ▶ Maximum pressure 420bar
- ▶ Open circuit

Features

- ▶ Variable pump with axial piston rotary group in swashplate design for hydrostatic drives in open circuit.
- ▶ For use particularly in industrial application areas
- ▶ Flow is proportional to the drive speed and displacement.
- ▶ Flow can be infinitely varied by controlling the swashplate angle.
- ▶ The pump can work either self-priming or with a charge pump.
- ▶ Special control device program for industrial applications, with different control and regulation functions.
- ▶ The universal through drive is suitable for adding gear wheel pumps and axial piston pumps of up to the same size, i.e. 100% through drive.
- ▶ Compact design
- ▶ High efficiency
- ▶ High power density
- ▶ Low noise level

Contents

Type code	2
Hydraulic fluids	6
Charge pump (impeller)	7
Working pressure range	8
Technical data	9
Power controller	13
Stroke control	17
Pressure controller	24
Dimensions, size 110	31
Dimensions, size 145	35
Dimensions, size 175	40
Dimensions, size 210	45
Dimensions, size 280	50
Dimensions, through drive	55
Overview of mounting options	61
Combination pumps A15V... + A15V...	62
Connector for solenoids	63
Installation instructions	64
Project planning notes	66
Safety instructions	67

Type code

01	02	03	04	05	06	07	08	09	10	11	12	13	14	15	16	17	18	19	20	
									/	11			V					0	-	

Axial piston unit

01	Variable swashplate design, nominal pressure 350bar, maximum pressure 420bar	unpainted	A15V
		painting	LA15V

Operating mode¹⁾

		110	145	175	210	280	
02	Pump, open circuit						
	without charge pump	•	•	•	•	•	SO
	with charge pump	-	•	•	•	•	LO

Size (NG)

03	Geometric displacement, see table of values on page 9	110	145	175	210	280
----	---	------------	------------	------------	------------	------------

Swiveling range

		110	145	175	210	280	
04	One-sided swiveling						
	$V_{g \max}$: + 50% to + 100% ³⁾	•	•	•	•	•	
	$V_{g \min}$: - 5% to + 30%						
	Two-sided swiveling ²⁾						
	$V_{g \max}$: + 50% to + 100% ³⁾	•	•	•	•	•	M
	$V_{g \min}$: - 100% to - 50% ⁴⁾						

Position 05, 06, 07 with the relevant control axis combination option, controller group a) to e) is described below

Type code position	05	06	07
Combination options	a) Power controller Not for swiveling range "M"	No other controller, without code	
		b) Pressure controller	No other controller, without code
			c) Stroke control
			d) Load-sensing
			e) Override DG
		c) Stroke control	No other controller, without code
		d) Load-sensing	
		d) Load-sensing	No other controller, without code
	b) Pressure controller	No other controller, without code	
		b) Pressure controller ⁵⁾	No other controller, without code
			e) Override DG
		d) Load-sensing	No other controller, without code
e) Override DG		No other controller, without code	
e) Override DG		No other controller, without code	
c) Stroke control Not for swiveling range "M"	No other controller, without code		
	b) Pressure controller	No other controller, without code	
		e) Override DG	
	d) Load-sensing	No other controller, without code	

• = Available ◦ = On request - = Not available

1) Note the selection option depending on the rotary group version.

2) Not possible with charge pump (VLO).

3) Values deviating at NG 145: $V_{g \max}$: + 75% to + 100%

4) Values deviating at NG 145: $V_{g \min}$: - 75% to - 100%

5) Cannot be combined with the same pressure controller

01	02	03	04	05	06	07	08	09	10	/	11	12	13	14	15	16	17	18	19	20	
														V					0	-	

Control device: Controller group a) **110 145 175 210 280**

a)	Power controller	fixed setting			●	●	●	●	●		
		Override electric-proportional	negative control	$U = 24\text{ V}$	●	●	●	●	●	●	●
	Summation power controller	Override	negative control	with stop	●	●	●	●	●	●	●
		hydraulic-proportional, high pressure		without stop	●	●	●	●	●	●	●

Controller group b) **110 145 175 210 280**

b)	Without additional controller (without symbol)										●	●	●	●	●			
	Pressure controller with one-side swiveling	fixed setting										●	●	●	●	●	●	DR
		remote controlled hydraulically					positive control					●	●	●	●	●	●	DG
		for parallel operation					positive control					●	●	●	●	●	●	DP ¹⁾

Controller group c) **110 145 175 210 280**

c)	Without additional controller (without symbol)										●	●	●	●	●			
	Stroke control	electric-proportional					positive control					$U = 24\text{ V}$	●	●	●	●	●	E2
		electric, two-point					positive control					$U = 24\text{ V}$	●	●	●	●	●	E6
		hydraulic-proportional, Pilot pressure					negative control					●	●	●	●	●	●	H3
							positive control					●	●	●	●	●	●	●
							negative control					●	●	●	●	●	●	H5
							positive control					●	●	●	●	●	●	●

Controller group d) **110 145 175 210 280**

d)	Without additional controller (without symbol)										●	●	●	●	●			
	Load-sensing, pump pressure internal	fixed setting										●	●	●	●	●	●	S0
		Pressure controller	remote controlled hydraulically					positive control					●	●	●	●	●	●

Controller group e) **110 145 175 210 280**

e)	Without additional controller (without symbol)										●	●	●	●	●			
	Electric directional valve and pressure relief valve mounted	only in combination with DG					De-energized standby					$U = 24\text{ V}$	●	●	●	●	●	V2
		Override DG with integrated pilot control valve and only in combination with DG					positive control					$U = 24\text{ V}$	●	●	●	●	●	●
	negative control						$U = 24\text{ V}$	●	●	●	●	●	●	●	●	T8		

● = Available ○ = On request - = Not available

1) Cannot be combined with additional control: stroke control

4 **A15VSO, A15VLO Series 11** | Axial piston variable pump
Type code

01	02	03	04	05	06	07	08	09	10	11	12	13	14	15	16	17	18	19	20	
									/	11			V					0	-	

		110	145	175	210	280
08	Basic position maximum swivel angle ($V_{g\max}$)					
	Without external control pressure supply (standard for power and pressure controllers)	•	•	•	•	A
	With external control pressure supply (integrated shuttle valve, standard for negative stroke control)	•	•	•	•	B
	Basic position minimum swivel angle ($V_{g\min}$)					
	With external control pressure supply (integrated shuttle valve, standard for positive stroke control)	•	•	•	•	C

		110	145	175	210	280
09	Without connector (without solenoid, only for hydraulic control)	•	•	•	•	0
	HIRSCHMANN connector	•	•	•	•	H

		110	145	175	210	280
10	Without swivel angle sensor (only for A15VLO)	•	•	•	•	0
	Optical swivel angle indicator (only for A15VSO)	•	•	•	•	V
	With electrical swivel angle sensor ⁸⁾ (as per data sheet 95150)					
	Power supply 5V DC	•	•	•	•	B
	Power supply 8V – 32V DC	•	•	•	•	K

Series		11
11	Series 1, index 1	11

Version of port and fastening threads		M
12	Metric, all fastening threads according to DIN 13, all port threads with O-ring seal according to ISO 6149	M

		110	145	175	210	280
13	Viewed on drive shaft	clockwise	•	•	•	R
		counter-clockwise	•	•	•	L

		110	145	175	210	280
14	FKM (fluoroelastomer)	•	•	•	•	V

		110	145	175	210	280
15	SAE J744	152-4	•	•	-	D4
		165-4	-	-	•	E4

		110	145	175	210	280	
16	Splined shaft DIN 5480	W45x2x21x9g	•	-	-	A1	
		W50x2x24x9g	-	•	•	A2	
		W60x2x28x9g	-	-	-	•	A4
	Parallel keyed shaft DIN 6885 (not for A15VLO)	ø45	•	-	-	-	B1
		ø50	-	•	•	•	B2
		ø60	-	-	-	•	B4

		110	145	175	210	280
17	Standard version without charge pump	•	-	-	-	E
	Efficiency and speed optimized (version with and without charge pump)	-	•	•	•	P

• = Available ◦ = On request - = Not available

6) For description, see "Control device".
Tables from page 12

7) Connectors for other electric components may deviate

8) Please contact us if the swivel angle sensor is used for control

Hydraulic fluids

The A15VSO, A15VLO variable pump is designed for operation with HLP mineral oil according to DIN 51524. See the following data sheets for application instructions and requirements for hydraulic fluids before the start of project planning:

- ▶ 90220: Hydraulic fluids based on mineral oils and related hydrocarbons
- ▶ 90221: Environmentally acceptable hydraulic fluids
- ▶ 90222: Fire-resistant, water-free hydraulic fluids (HFDR/HFDU)

Selection of hydraulic fluid

Bosch Rexroth evaluates hydraulic fluids on the basis of the Fluid Rating according to the technical data sheet 90235. Hydraulic fluids with positive evaluation in the Fluid Rating are provided in the following technical data sheet: 90245: Bosch Rexroth Fluid Rating List for Rexroth hydraulic components (pumps and motors)

Selection of hydraulic fluid shall make sure that the operating viscosity in the operating temperature range is within the optimum range (v_{opt} ; see selection diagram).

Viscosity and temperature of hydraulic fluids

	Viscosity	Shaft seal	Temperature ³⁾	Comment
Cold start	$v_{max} \leq 1600 \text{mm}^2/\text{s}$	NBR ²⁾	$\theta_{St} \geq -40^\circ\text{C}$	$t \leq 3 \text{min}$, without load ($p \leq 50 \text{bar}$), $n \leq 1000 \text{rpm}$ Permissible temperature difference between axial piston unit and hydraulic fluid in the system maximum 25 K
		FKM	$\theta_{St} \geq -25^\circ\text{C}$	
Warm-up phase	$v = 1600 \dots 400 \text{mm}^2/\text{s}$			$t \leq 15 \text{min}$, $p \leq 0.7 \times p_{nom}$ and $n \leq 0.5 \times n_{nom}$
Continuous operation	$v = 400 \dots 10 \text{mm}^2/\text{s}^{1)}$	NBR ²⁾	$\theta \leq +85^\circ\text{C}$	measured at port T
		FKM	$\theta \leq +110^\circ\text{C}$	
	$v_{opt} = 36 \dots 16 \text{mm}^2/\text{s}$			optimal operating viscosity and efficiency range
Short-term operation	$v_{min} = 10 \dots 7 \text{mm}^2/\text{s}$	NBR ²⁾	$\theta \leq +85^\circ\text{C}$	$t \leq 3 \text{min}$, $p \leq 0.3 \times p_{nom}$, measured at port T
		FKM	$\theta \leq +110^\circ\text{C}$	

▼ Selection diagram

Maximum permissible viscosity on cold start

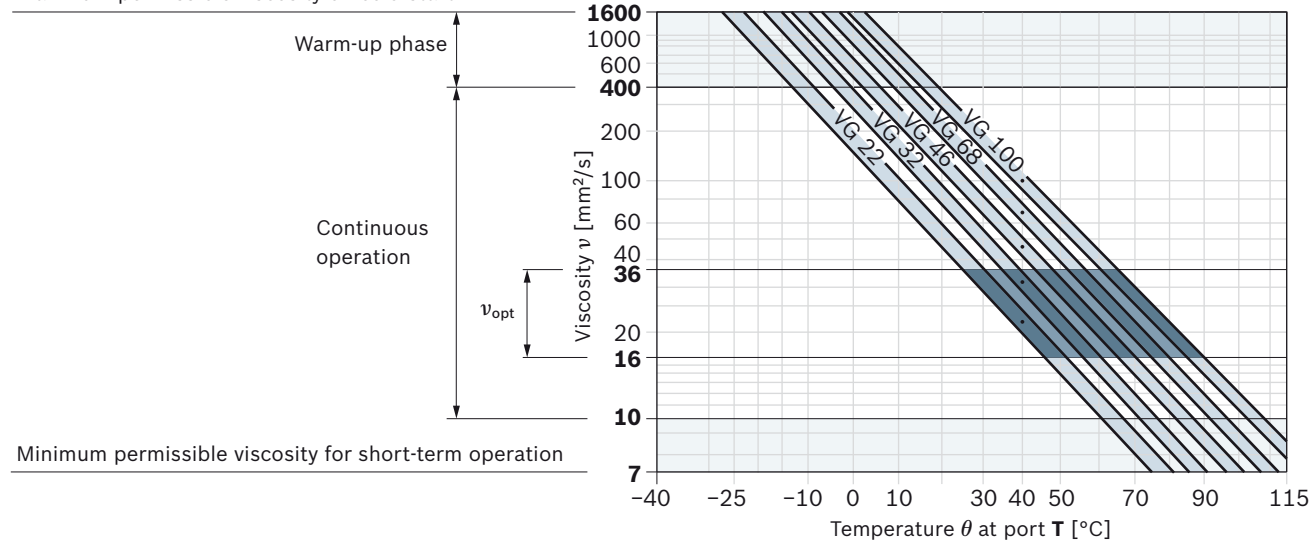

1) This corresponds, for example on the VG 46, to a temperature range of +4°C to +85°C (see selection diagram)

2) Special version, please contact us

3) If the temperature at extreme operating parameters cannot be adhered to, please contact us.

Working pressure range

Pressure at working port A		Definition
Nominal pressure p_{nom}	350bar	The nominal pressure corresponds to the maximum design pressure.
Maximum pressure p_{max}	420bar	The maximum pressure corresponds to the maximum working pressure within a single operating period. The sum of the single operating periods must not exceed the total operating period (maximum number of cycles: approx. 1 million).
Single operating period	1 s	
Total operating period	300h	
Minimum pressure $p_{A abs}$ (High-pressure side)	15bar ¹⁾²⁾	Minimum pressure at the high-pressure side (A) which is required in order to prevent damage to the axial piston unit. The minimum pressure depends on the rotational speed and the swivel angle.
Rate of pressure change $R_{A max}$	16000bar/s	Maximum permissible pressure build-up and reduction speed during a pressure change across the entire pressure range.
Pressure at suction port S (inlet)		
Version without charge pump (A15VSO)		Minimum pressure at suction port S (inlet) which is required to prevent damage to the axial piston unit. The minimum pressure depends on the rotational speed and displacement volume of the axial piston unit (see diagram on page 11 and footnote ⁴⁾ Technical data on page 9 and 10).
Minimum pressure $p_{S min}$	$\geq 0.8\text{bar abs.}$	
Maximum pressure $p_{S max}$	$\leq 30\text{bar}$	
Version with charge pump (A15VLO)		
Minimum pressure $p_{S min}$	$\geq 0.7\text{bar abs.}$	
Maximum pressure $p_{S max}$	$\leq 2\text{bar abs.}$	
Case pressure at port T ₁ , T ₂ , T ₃		
Max. static pressure $p_{L max}$	3bar	Maximum 1.2bar higher than inlet pressure at port S, but not higher than $p_{L max}$. A drain line to the reservoir is required.
Pressure peaks $p_{L peak}$	6bar	$t < 0.1\text{s}$

▼ Pressure definition

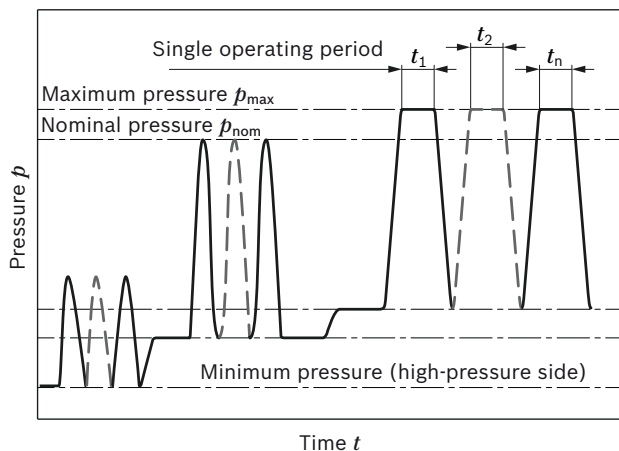

$$\text{Total operating period} = t_1 + t_2 + \dots + t_n$$

1) Lower values on request
2) See also footnote 4 on page 9 and 10

Notice

Working pressure range applies when using hydraulic fluids based on mineral oils. Please contact us for values for other hydraulic fluids.

Technical data

Engine version E and P without charge pump (A15VSO)

Size			NG	110	145	175	210	280	
Geometric displacement, per revolution			$V_{g \max}$	cm ³	110.0	145.0	175.0	210.0	280.0
			$V_{g \min}$	cm ³	0	0	0	0	0
Maximum rotational speed ¹⁾	at $V_{g \max}$ ²⁾ Version E		n_{nom}	rpm	2400	–	–	–	–
	at $V_{g \max}$ ²⁾ Version P				–	2300	2150	2100	1800
	at $V_g \leq V_{g \max}$ ³⁾ Version E		n_{max}	rpm	2400	–	–	–	–
	at $V_g \leq V_{g \max}$ ³⁾ Version P				–	2600	2500	2350 ⁴⁾	2150 ⁴⁾
Flow	at n_{nom} and $V_{g \max}$		q_v	l/min	264	334	376	441	504
Power	at n_{nom} , $V_{g \max}$ and $\Delta p = 350\text{bar}$		P	kW	154	195	219	257	294
Torque	at $V_{g \max}$ and $\Delta p = 350\text{bar}^2)$		M	Nm	613	808	975	1170	1560
Rotary stiffness Drive shaft	W45x2x21x9g	A1	c	kNm/rad	242	–	–	–	–
	W50x2x24x9g	A2	c	kNm/rad	–	334	357	381	–
	W60x2x28x9g	A4	c	kNm/rad	–	–	–	–	645
	∅45	B1	c	kNm/rad	236	–	–	–	–
	∅50	B2	c	kNm/rad	–	337	349	372	–
	∅60	B4	c	kNm/rad	–	–	–	–	620
Moment of inertia of the rotary group	Version E		J_{TW}	kgm ²	0.022	–	–	–	–
	Version P		J_{TW}	kgm ²	–	0.035	0.045	0.06	0.097
Maximum angular acceleration ⁵⁾	Version E		α	rad/s ²	7465	–	–	–	–
	Version P		α	rad/s ²	–	6298	5609	5014	4200
Case volume			V	l	2.2	2.7	3.6	4	6.5
Weight (without through drive) approx.			m	Kg	64	79	97	111	143

Notes

- ▶ Theoretical values, without efficiency and tolerances; values rounded
- ▶ Operation above the maximum values or below the minimum values may result in a loss of function, a reduced service life or in the destruction of the axial piston unit. We recommend checking loads through tests or calculation/simulation and comparing them with the permissible values.
- ▶ Special requirements apply in the case of belt drives. Please contact us.

- The values are applicable:
 - for the optimum viscosity range from $\nu_{\text{opt}} = 36$ to $16\text{mm}^2/\text{s}$
 - with hydraulic fluid based on mineral oils
- The values apply at absolute pressure $p_{\text{abs}} = 1\text{bar}$ at suction port **S**.
- Maximum rotational speed (speed limit) for increased inlet pressure p_{abs} at suction port **S** and $V_g < V_{g \max}$, see diagram page 11.
- The rotational speed can be increased under the following conditions:

NG	Rotational speed [rpm]	Pressure on port A $p_{A \text{ abs}}$ [bar]	Swivel angle [%]
280	2300	at least 35	at least 10
210	2500	at least 35	at least 10

Determining the operating characteristics

Flow	$q_v = \frac{V_g \times n \times \eta_v}{1000}$	[l/min]
Torque	$M = \frac{V_g \times \Delta p}{20 \times \pi \times \eta_{\text{hm}}}$	[Nm]
Power	$P = \frac{2 \pi \times M \times n}{60000} = \frac{q_v \times \Delta p}{600 \times \eta_t}$	[kW]
Key		
V_g	=	Displacement per revolution [cm ³]
Δp	=	Differential pressure [bar]
n	=	Rotational speed [rpm]
η_v	=	Volumetric efficiency
η_{hm}	=	Hydraulic-mechanical efficiency
η_t	=	Total efficiency ($\eta_t = \eta_v \times \eta_{\text{hm}}$)

- The data are valid for values between the minimum required and maximum permissible rotational speed. Valid for external excitation (e.g. diesel engine 2 to 8 times rotary frequency; cardan shaft twice the rotary frequency). The limit value is only valid for a single pump. The load capacity of the connection parts must be considered.

Technical data

With charge pump (A15VLO) Rotary group version P

Geometric displacement, per revolution		$V_{g \max}$	cm ³	145.0	175.0	210.0	280.0
		$V_{g \min}$	cm ³	0	0	0	0
Maximum rotational speed ¹⁾	at $V_{g \max}$ ²⁾	n_{nom}	rpm	2600	2500	2350 ⁴⁾	2150 ⁴⁾
	at $V_g \leq V_{g \max}$	n_{max}	rpm	2600 ³⁾	2500 ³⁾	2350 ⁴⁾	2150 ⁴⁾
Flow	at n_{nom} and $V_{g \max}$	q_v	l/min	377	438	493	602
Power	at n_{nom} , $V_{g \max}$ and $\Delta p = 350 \text{ bar}$	P	kW	220	255	288	351
Torque	at $V_{g \max}$ and $\Delta p = 350 \text{ bar}$ ²⁾	M	Nm	808	975	1170	1560
Rotary stiffness	W50x2x24x9g A2	c	kNm/rad	334	357	381	–
Drive shaft	W60x2x28x9g A4	c	kNm/rad	–	–	–	645
Moment of inertia		J_{TW}	kgm ²	0.035	0.047	0.063	0.1
Maximum angular acceleration ⁵⁾		α	rad/s ²	6298	5609	5014	4100
Case volume		V	l	2.9	3.6	3.7	5.6
Weight (without through drive) approx.		m	Kg	92	110	125	148

Notes

- ▶ Theoretical values, without efficiency and tolerances; values rounded
- ▶ Operation above the maximum values or below the minimum values may result in a loss of function, a reduced service life or in the destruction of the axial piston unit. We recommend checking loads through tests or calculation/simulation and comparing them with the permissible values.
- ▶ Special requirements apply in the case of belt drives. Please contact us.

Determining the operating characteristics

Flow	$q_v = \frac{V_g \times n \times \eta_v}{1000}$	[l/min]
Torque	$M = \frac{V_g \times \Delta p}{20 \times \pi \times \eta_{\text{hm}}}$	[Nm]
Power	$P = \frac{2 \pi \times M \times n}{60000} = \frac{q_v \times \Delta p}{600 \times \eta_t}$	[kW]
Key		
V_g	=	Displacement per revolution [cm ³]
Δp	=	Differential pressure [bar]
n	=	Rotational speed [rpm]
η_v	=	Volumetric efficiency
η_{hm}	=	Hydraulic-mechanical efficiency
η_t	=	Total efficiency ($\eta_t = \eta_v \times \eta_{\text{hm}}$)

- 1) The values are applicable:
 - for the optimum viscosity range from $\nu_{\text{opt}} = 36$ to $16 \text{ mm}^2/\text{s}$
 - with hydraulic fluid based on mineral oils
- 2) The values apply at absolute pressure $p_{\text{abs}} = 1 \text{ bar}$ at suction port **S**.
- 3) Maximum rotational speed (speed limit) for increased inlet pressure p_{abs} at suction port **S** and $V_g < V_{g \max}$, see diagram page 11.
- 4) The rotational speed can be increased under the following conditions:

NG	Rotational speed [rpm]	Pressure on port A $p_{\text{A abs}}$ [bar]	Swivel angle [%]
280	2300	at least 35	at least 10
210	2500	at least 35	at least 10

- 5) The data are valid for values between the minimum required and maximum permissible rotational speed. Valid for external excitation (e.g. diesel engine 2 to 8 times rotary frequency; cardan shaft twice the rotary frequency). The limit value is only valid for a single pump. The load capacity of the connection parts must be considered.

▼ **Maximum permissible rotational speed (speed limit)**

($p_{s\ abs}$ = Inlet pressure [bar])

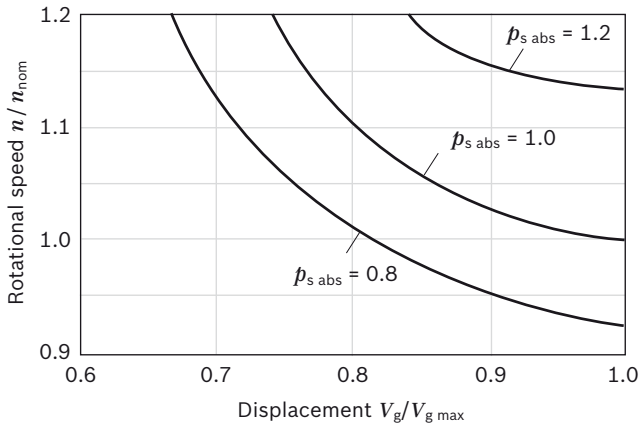

Notes

- The maximum permissible rotational speed n_{max} must not be exceeded (see table of values on page 9).

Permissible radial and axial loading on the drive shafts

Size		NG	110	110	145	145	175	175	210	210	280	280	280	
Drive shaft			Ø 45	W45	Ø 50	W50	Ø 50	W50	Ø 50	W50	Ø 60	W60	W60	
Maximum radial force at distance a (from shaft collar)		$F_{q\ max}$	N	8000	8000	11000	11000	14000	14000	17000	17000	20000	23600	23600
		a	mm	41	25	41	27.5	41	27	41	27	52.5	29	29
Axial force max.		$+ F_{ax\ max}$	N	1200	1200	1350	1350	1400	1400	1450	1450	1800	1800	1800
		$- F_{ax\ max}$	N	500	500	600	600	650	650	700	700	850	850	850

Notes

- Belt drive requires special conditions. Please contact us!

Permissible input and through-drive torques

Size	NG		110	145	175	210	280	
Torque at $V_{g \max}$ and $\Delta p = 350 \text{ bar}^{1)}$		M_{\max}	Nm	610	808	975	1170	1560
Maximum input torque on drive shaft ²⁾								
A1	W 45	$M_{E \max}$	Nm	2190	–	–	–	–
A2	W 50	$M_{E \max}$	Nm	–	3140	3140	3140	–
A4	W 60	$M_{E \max}$	Nm	–	–	–	–	5780
B1	Ø 45	$M_{E \max}$	Nm	1050	–	–	–	–
B2	Ø 50	$M_{E \max}$	Nm	–	1500	1500	1500	–
B4	Ø 60	$M_{E \max}$	Nm	–	–	–	–	2800
Maximum through-drive torque		$M_{D \max}$	Nm	960	1110	1340	1915	2225

▼ Distribution of torques

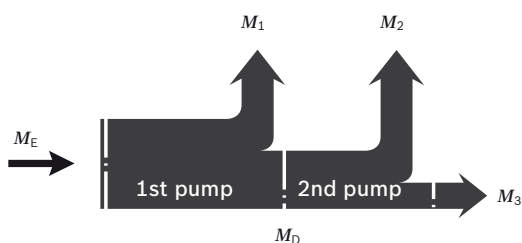

Torque at 1st pump	M_1
Torque at 2nd pump	M_2
Torque at 3rd pump	M_3
Input torque	$M_E = M_1 + M_2 + M_3$
	$M_E < M_{E \max}$
Through-drive torque	$M_D = M_2 + M_3$
	$M_D < M_{D \max}$

External control pressure supply (type code position 08 B and C)

Control systems with external control pressure supply need a flow appropriate to the adjustment time and size.

See also page 18

Size	Flow rate [l/min] With 100ms swivel time
110	10
145	13
175	14
210	17
280	22

1) Efficiency not considered
 2) For drive shafts free of radial force

Power controller

LR – Power controller, fixed setting

The power controller regulates the displacement of the pump depending on the working pressure so that a given drive power is not exceeded at constant drive speed. The precise control with a hyperbolic characteristic curve, provides an optimum utilization of available power. The working pressure acts on a rocker via a measuring spool moved together with the control. An externally adjustable spring force counteracts this, it determines the power setting. The depressurized basic position is $V_{g \max}$. If the working pressure exceeds the set spring force, the control valve will be actuated by the rocker and the pump will swivel back from the basic position $V_{g \max}$ toward $V_{g \min}$. Here, the leverage at the rocker may be shortened and the operating pressure may rise in the same relation as the displacement is reduced ($p_B \times V_g = \text{constant}$; p_B = operating pressure; V_g = displacement). The hydraulic output power (characteristic curve LR) is influenced by the efficiency of the pump. Setting range for beginning of control is 50bar to 350bar (see table on the right).

When ordering, state in plain text:

- ▶ Drive power P [kW]
- ▶ Drive speed n [rpm]
- ▶ Maximum flow $q_{V \max}$ [l/min]

Please contact us if you need a performance chart.

▼ Characteristic curve LR

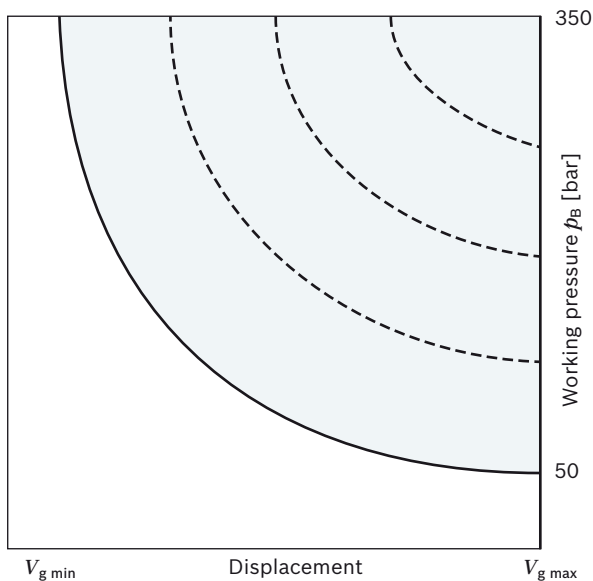

▼ Circuit diagram LR

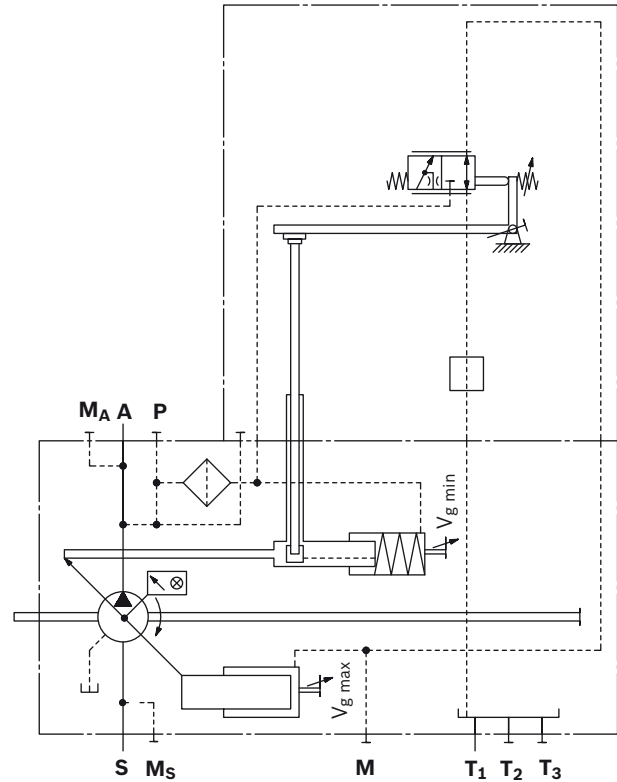

Size	Rotational speed [rpm]		
	1000	1500	1800
	Minimum adjustable drive power [kW] (at 50bar beginning of control)		
110	11	17	20
145	14	21	25
175	17	25	30
210	20	30	36
280	26	39	47

L4 – Power controller, electric-proportional override (negative control)

A control current acts against the adjustment spring of the power controller via a proportional solenoid.

The mechanically adjusted basic power setting can be reduced by means of different control current settings. Increasing control current = reduced power.

The following amplifiers are recommended for industrial applications and are available for controlling the proportional solenoids:

- ▶ Analog amplifier VT-VSPA1-1 data sheet 30111
- ▶ Digital amplifier VT-VSPD-1 data sheet 30523

Further information can also be found on the Internet at www.boschrexroth.com/industrial-hydraulics-catalog/

Technical data, solenoid	L4
Voltage	24V (±20%)
Control current	
Beginning of control	200mA
End of control	600mA
Current limit	0.77A
Nominal resistance (at 20°C)	22.7Ω
Dither frequency	100Hz
Duty cycle	100%
Type of protection: see connector version page 63	

When ordering, state in plain text:

- ▶ Drive power P [kW] at beginning of control
- ▶ Drive speed n [rpm]
- ▶ Maximum flow $q_{V \max}$ [l/min]

Effect of power override through current increase or de-energized operating condition

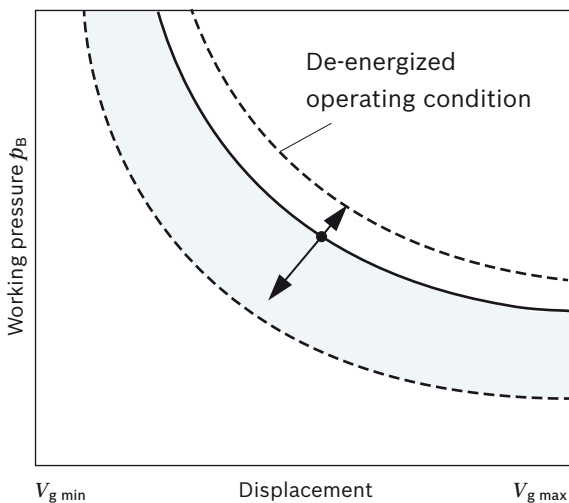

Notice
In operating condition **L4** de-energized (jump 200 to 0mA): Power increase by a factor of 1 of the table values.

Circuit diagram L3/L4

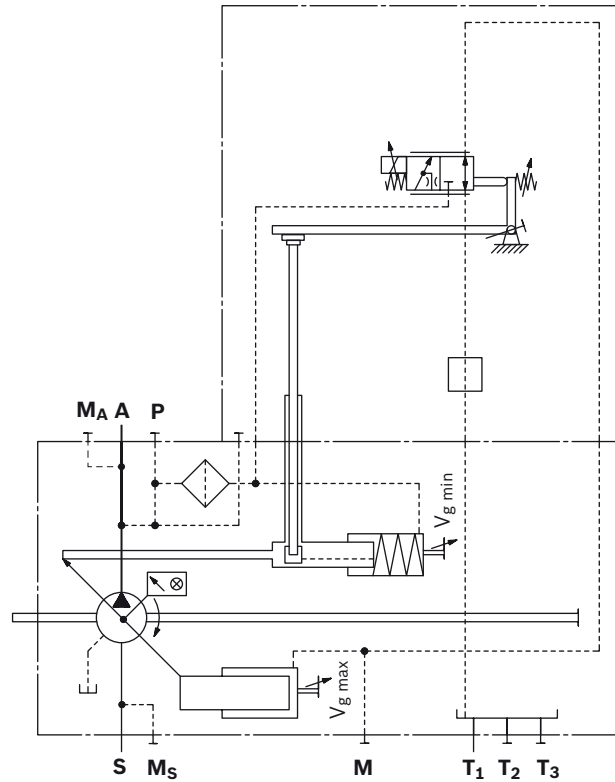

Reduction of power by control current to the proportional solenoids with **L4**¹⁾

Power reduction/control current [kW/100mA]

Size	Rotational speed [rpm]		
	1000	1500	1800
110	12.3	18.5	22.1
145	14.8	22.2	26.6
175	16.8	25.2	30.2
210	18.9	28.4	34.0
280	22.9	34.4	41.2

1) Values in the tables are reference points. Determination of the exact power override on request.

CR – Summation power control of two power-controlled pumps, high-pressure-related override (with stop)

With two pumps of the same size working in different operating circuits, the CR controller limits the overall power.

The CR works like the normal LR with a fixed maximum power setting along the power hyperbola. The high-pressure-related override reduces the power setpoint in dependence on the working pressure of the other pump. That happens proportionally below the beginning of control and is blocked by a stop when the minimum power is reached. Here, the **CR** port of the one pump has to be connected to the **M_A** port of the other pump. The maximum power of the first pump is reached when the second pump is working at idle when depressurized. When defining the maximum power, the idle power of the second pump has to be taken into account.

The minimum power of each pump is reached when both pumps are working at high pressure. The minimum power usually equates to 50% of the total power.

Power that is released by the pressure controller or other overrides remains unconsidered.

Setting range for beginning of control is 50bar to 300bar.

When ordering, please specify separately for each pump:

- ▶ Maximum drive power P_{max} [kW]
- ▶ Minimum drive power P_{min} [kW]
- ▶ Drive speed n [rpm]
- ▶ Maximum flow q_{Vmax} [l/min]

▼ Characteristic curve CR

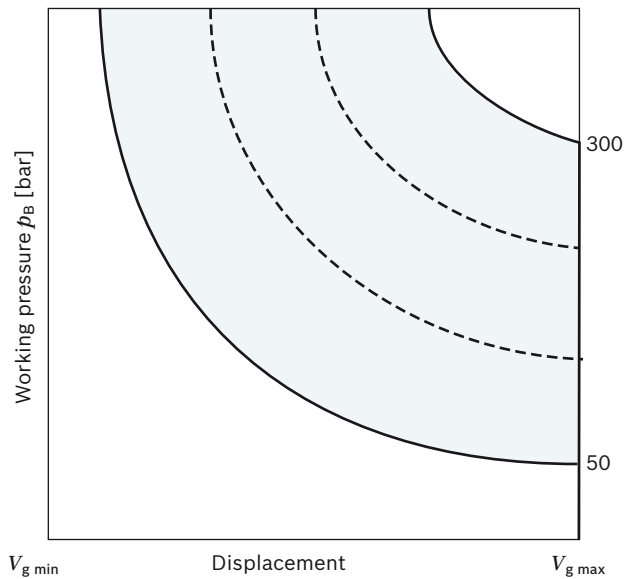

▼ Circuit diagram CR

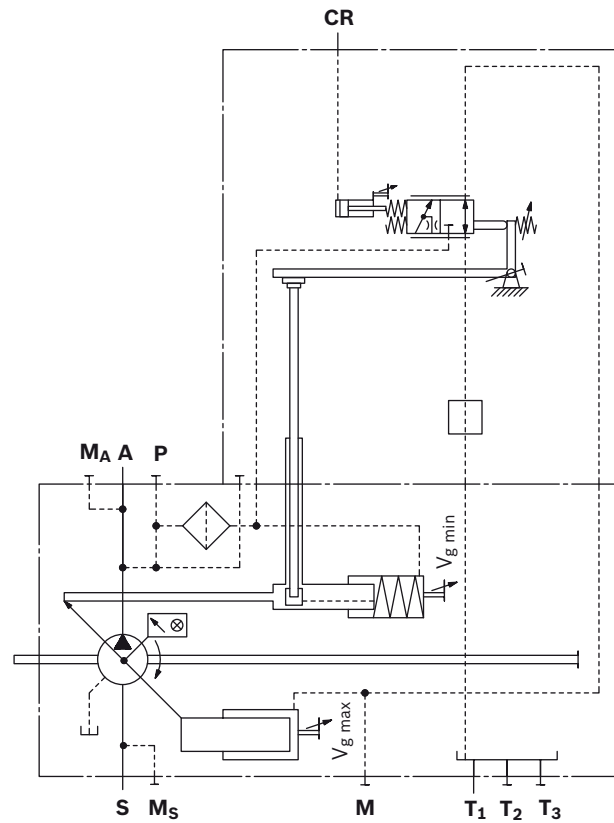

▼ Effect of power override of a pump with increasing pressure in the 2nd pump

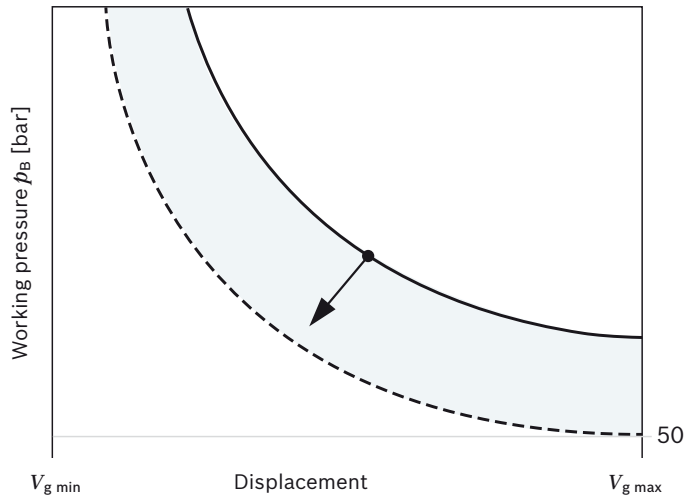

PR – Summation power control of a power-controlled pump and a constant pump

Together with the mounted fixed pump, the PR controller on an A15V(L)O effects a limitation of the overall power. The PR works like the normal LR with a fixed maximum power setting along the power hyperbola.

The high-pressure-dependent override reduces the power specification in proportion to the working pressure of the fixed pump. Here, port **PR** of the A15V(L)O must be connected to the working pressure of the fixed pump. The power of the controlled pump can then be reduced to zero in a borderline case.

The maximum power of the controlled pump is reached when the fixed pump works at idle when depressurized. When defining the maximum power, the idle power of the fixed pump has to be taken into account.

Power that is released by the pressure controller or other overrides remains unconsidered.

Setting range for beginning of control is 50bar to 350bar.

When ordering, state in plain text:

- ▶ Maximum drive power P_{max} [kW]
- ▶ Drive speed n [rpm]
- ▶ Maximum flow q_{Vmax} [l/min]
- ▶ Size of the fixed pump

▼ Characteristic curve PR

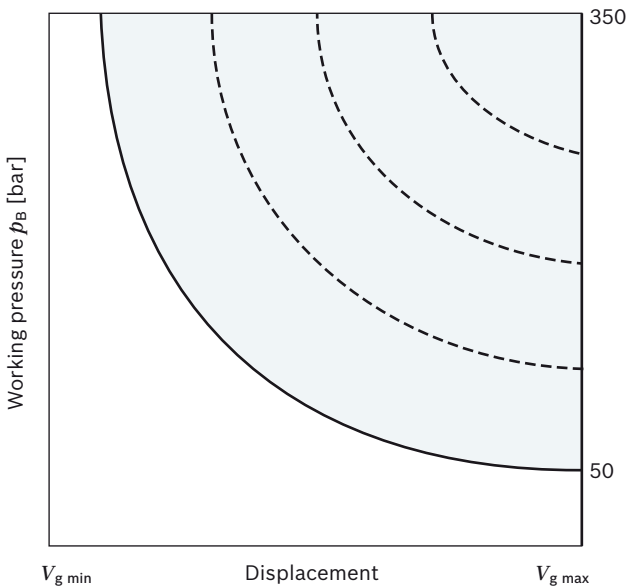

▼ Circuit diagram PR

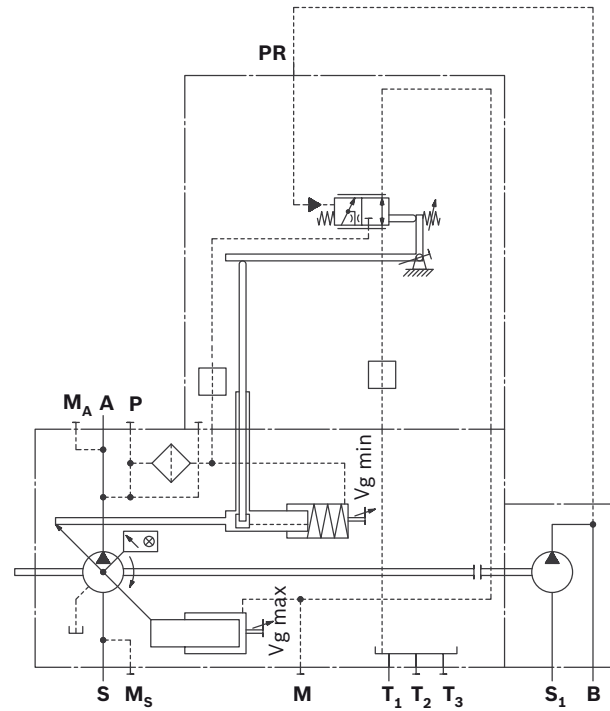

▼ Effect of power override of a pump with increasing pressure in the 2nd pump

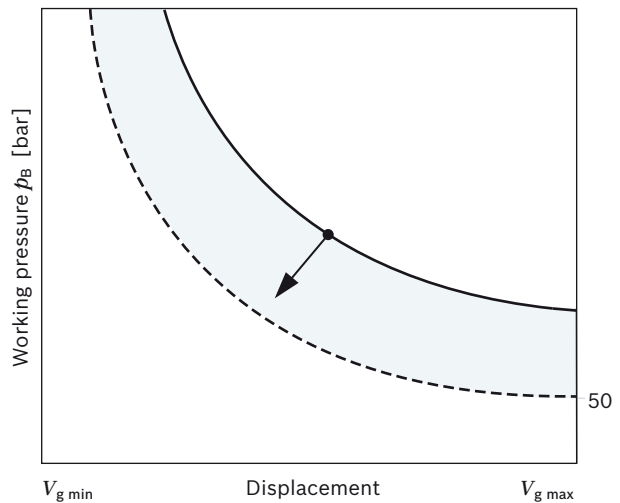

Stroke control

E2 – Stroke control electric-proportional (positive control)

With the electrical stroke control with proportional solenoid, the pump displacement is steplessly adjusted in proportion to the current via the magnetic force. Basic position without pilot signal is $V_{g \min}$. The mechanical depressurized basic position is $V_{g \min}$ (see type code 08, letter C). With increasing control current and flow, the pump swivels to a higher displacement (from $V_{g \min}$ to $V_{g \max}$). The required control fluid is taken from the working pressure or the external control pressure applied to port **P**. If the pump is to be adjusted from the basic position $V_{g \min}$ or from a low working pressure, port **P** must be supplied with an external control pressure of at least 30bar, maximum 50bar.

Notice

If there is no external control pressure applied to **P**, the version "Maximum swivel angle ($V_{g \max}$), without external control pressure supply" must be ordered (see type code position 08, A).

▼ Characteristic curve E2

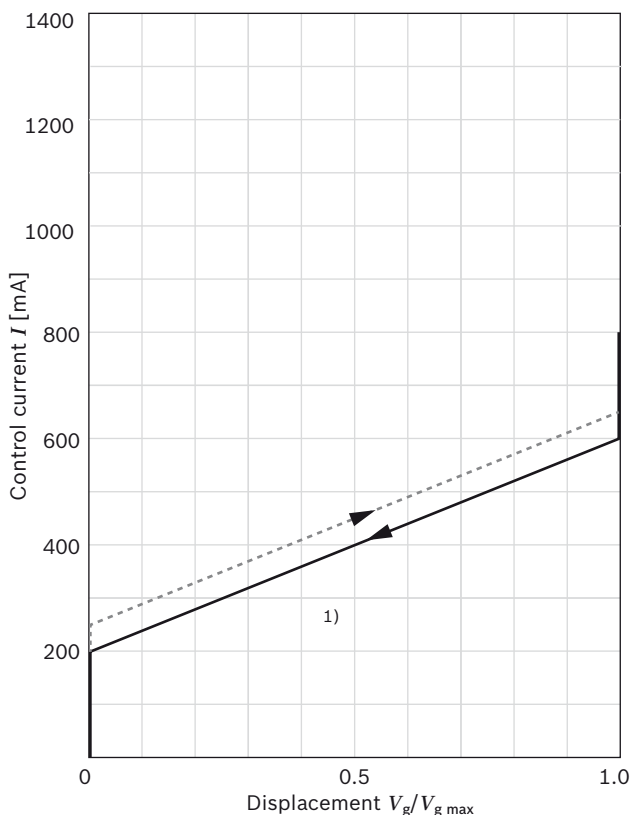

The following amplifiers are recommended for industrial applications and are available for controlling the proportional solenoids:

- ▶ Analog amplifier VT-VSPA1-1 data sheet 30111
- ▶ Analog amplifier VT-SSPA1-1 data sheet 30116
- ▶ Analog amplifier module VT-MSPA1-150 data sheet 30224
- ▶ Amplifier module VT-MSPA1-2X data sheet 30232

Further information can also be found on the Internet at www.boschrexroth.com/industrial-hydraulics-catalog/

Technical data, solenoid	E2
Voltage	24V ($\pm 20\%$)
Control current	
Start of control at $V_{g \min}$	200mA
End of control at $V_{g \max}$	600mA ¹⁾
Current limit	0.77A
Nominal resistance (at 20°C)	22.7Ω
Dither frequency	100Hz
Duty cycle	100%
Type of protection: see connector version page 63	

When ordering, state in plain text:

- ▶ Drive speed n [rpm]
- ▶ Maximum flow $q_{V \max}$ [l/min]
- ▶ Minimum flow $q_{V \min}$ [l/min]

See circuit diagram on page 18

Notice!

The spring feedback in the controller is not a safety device.

The controller can stick in an undefined position due to internal contamination (contaminated hydraulic fluid, abrasion or residual contamination from system components). As a result, the flow in the axial piston unit will no longer respond correctly to the operator's specifications.

Check whether the application on your machine requires additional safety measures to bring the driven consumer to a safe position (immediate stop). If necessary, make sure these are appropriately implemented.

¹⁾ Because of the control hysteresis, a control current of up to 650mA may be required for the $V_{g \max}$ position.

▼ **Circuit diagram E2**
Basic position A/B, depressurized at maximum swivel angle ($V_{g \max}$)

Shuttle valve only included when version "B" type code position 08 is selected

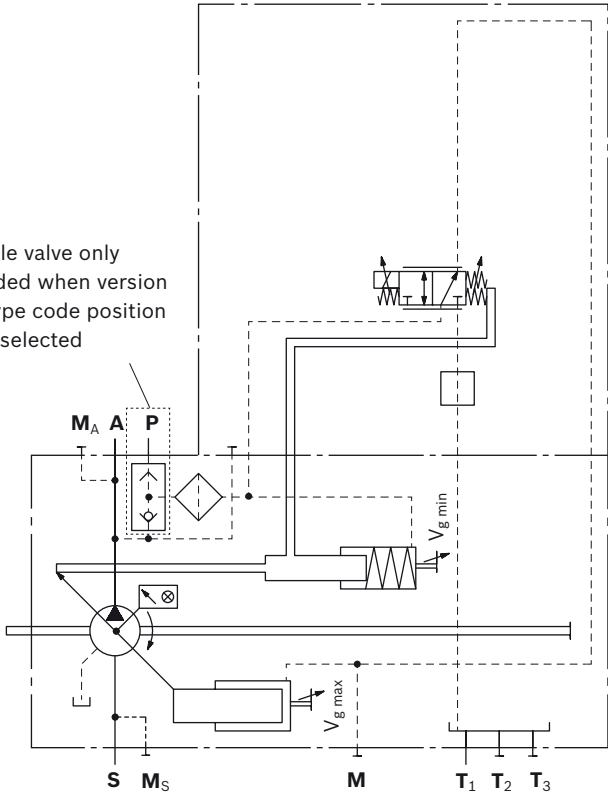

▼ **Circuit diagram E2**
Basic setting C, depressurized at minimum swivel angle ($V_{g \min}$)

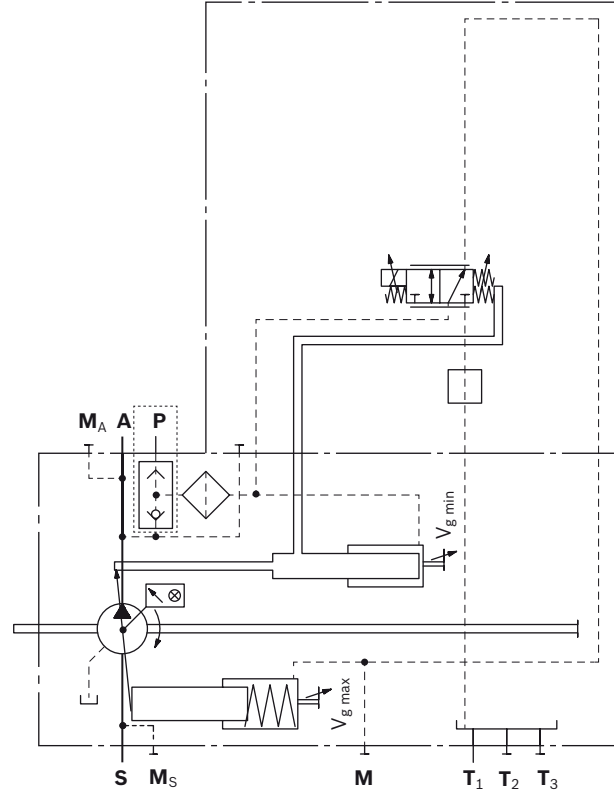

E6 – Stroke control, electric, proportional (positive control)

With the electric two-point stroke control with switching solenoid, the displacement of the pump is adjusted between $V_{g\ min}$ and $V_{g\ max}$.

Basic setting without current is $V_{g\ min}$. This includes the mechanically depressurized basic setting $V_{g\ min}$ (see type code digit 08).

When the solenoid is energized, the pump swivels from $V_{g\ min}$ to $V_{g\ max}$.

The required control power is taken from the working pressure or the external control pressure applied to port **P**. To enable the pump to be adjusted from the basic setting $V_{g\ min}$ or from a low working pressure, port **P** must be supplied with an external control pressure of at least 30bar, maximum 50bar.

Notice

If no external control pressure is connected to **P**, the version "Maximum swivel angle ($V_{g\ max}$), without external control pressure supply" must be ordered (see type code digit 08, A).

Technical data, solenoid	E6
Voltage	24V
Nominal resistance (at 20°C)	21.7Ω
Nominal power	26.5W
Test current	0.67A
Duty cycle	100%
Type of protection: see connector version page 63	

▼ **Circuit diagram E6**

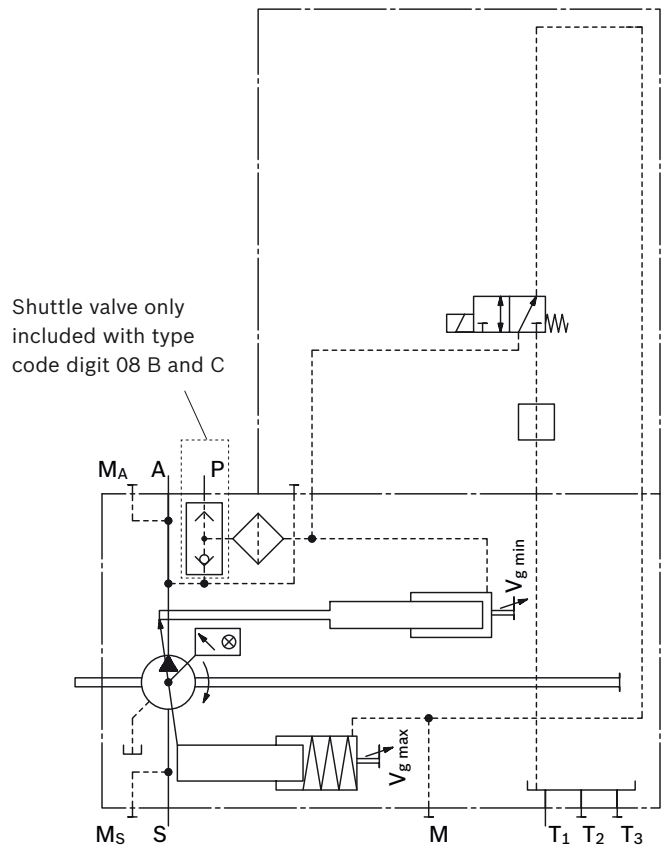

Notice

The spring feedback in the controller is not a safety device. The controller can stick in an undefined position due to internal contamination (contaminated hydraulic fluid, abrasion or residual contamination from system components). As a result, the flow in the axial piston unit will no longer respond correctly to the operator's specifications. Check whether your application requires that remedial measures be taken on your machine in order to bring the driven consumer into a safe position (e.g. immediate stop). If necessary, make sure these are appropriately implemented.

H3 – Stroke control, hydraulic-proportional, pilot pressure (negative control)

With pilot-pressure related control, the pump displacement is adjusted in proportion to the pilot pressure applied at port **H3**.

Basic position without pilot signal is $V_{g \max}$.

The mechanical depressurized basic position is $V_{g \max}$ (see type code 08, letter B).

- ▶ Control from $V_{g \max}$ to $V_{g \min}$; with increasing pilot pressure, the pump swivels to a smaller displacement.
- ▶ Setting range for start of control (at $V_{g \max}$) is 5bar to 10bar, standard is 10bar. State beginning of control in plain text in the order.
- ▶ Maximum permissible pilot pressure $p_{St \max} = 100\text{bar}$

The required control fluid is taken from the working pressure or the external control pressure applied to port **P**. If the pump is to be adjusted from the basic position $V_{g \min}$ or from a low working pressure, port **P** must be supplied with an external control pressure of at least 30bar, maximum 50bar.

Notice

If there is no external control pressure applied to **P**, the version "Maximum swivel angle ($V_{g \max}$), without external control pressure supply" must be ordered (see type code position 08, letter A).

▼ **Circuit diagram H3**

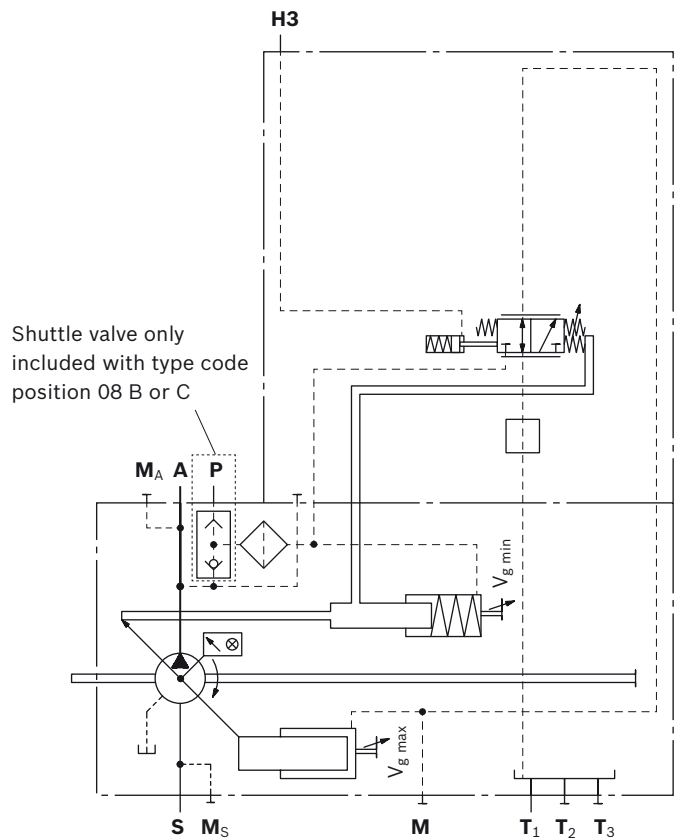

▼ **Characteristic curve H3 (negative)**

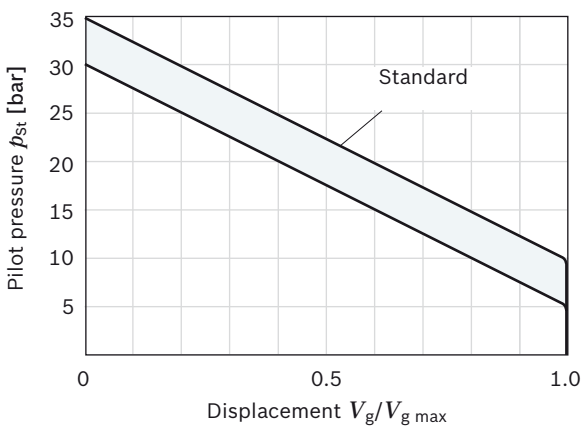

Pilot pressure increase $V_{g \max}$ to $V_{g \min}$: $\Delta p = 25\text{bar}$

When ordering, state in plain text:

- ▶ Beginning of control [bar] at $V_{g \max}$

H4 – Stroke control, hydraulic-proportional, pilot pressure (positive control)

With pilot-pressure related control, the pump displacement is adjusted in proportion to the pilot pressure applied at port **H4**.

Basic position without pilot signal is $V_{g\ min}$. The mechanical depressurized basic position is $V_{g\ min}$ (see type code position 08, letter C).

- ▶ Control from $V_{g\ min}$ to $V_{g\ max}$; with increasing pilot pressure the pump swivels to a larger displacement.
- ▶ Setting range for start of control (at $V_{g\ min}$) is 5bar to 10bar, standard is 10bar. State beginning of control in plain text in the order.
- ▶ Maximum permissible pilot pressure $p_{St\ max} = 100\text{bar}$

The required control fluid is taken from the working pressure or the external control pressure applied to port **P**. If the pump is to be adjusted from the basic position $V_{g\ min}$ or from a low working pressure, port **P** must be supplied with an external control pressure of at least 30bar, maximum 50bar.

Notice

If there is no external control pressure applied to **P**, the version "Maximum swivel angle ($V_{g\ max}$), without external control pressure supply" must be ordered (see type code position 08, letter A).

▼ **Characteristic curve H4 (positive)**

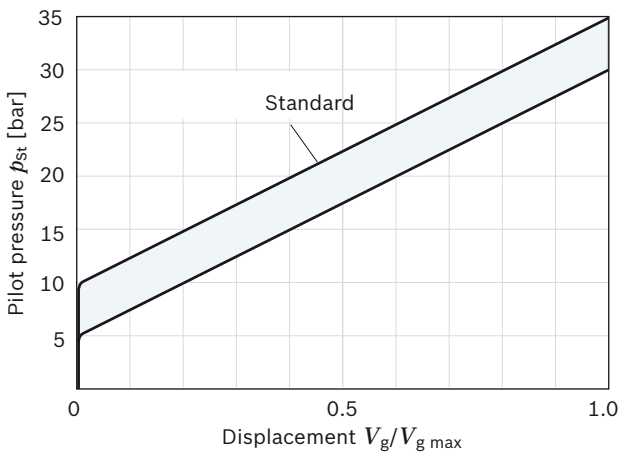

Pilot pressure increase $V_{g\ min}$ to $V_{g\ max}$: $\Delta p = 25\text{bar}$
When ordering, state in plain text:

- ▶ Beginning of control [bar] at $V_{g\ min}$

▼ **Circuit diagram H4**

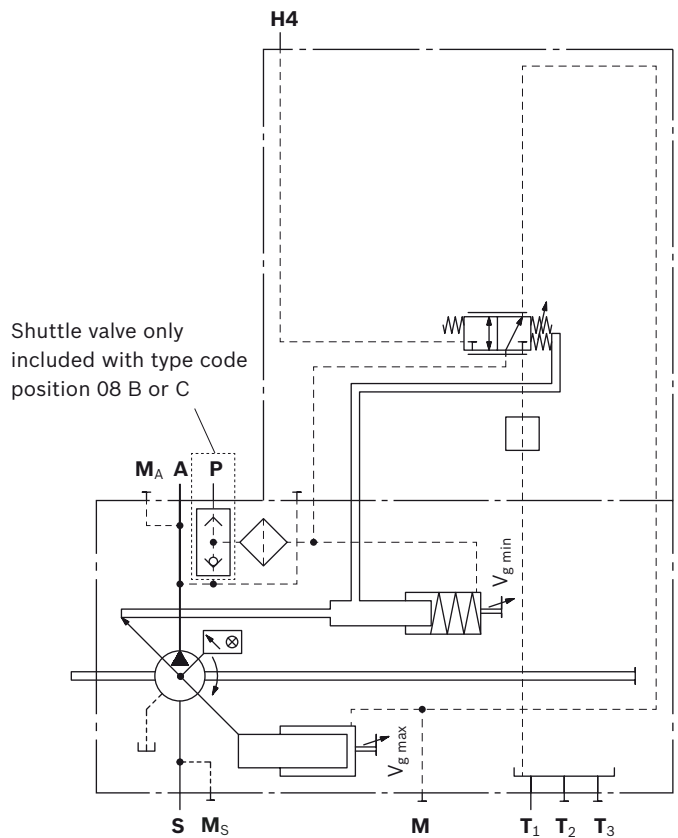

Notice!

The spring feedback in the controller is not a safety device. The controller can stick in an undefined position due to internal contamination (contaminated hydraulic fluid, abrasion or residual contamination from system components). As a result, the flow in the axial piston unit will no longer respond correctly to the operator's specifications. Check whether the application on your machine requires additional safety measures to bring the driven consumer to a safe position (immediate stop). If necessary, make sure these are appropriately implemented.

H5 – Stroke control, hydraulic-proportional, pilot pressure (negative control)

With pilot-pressure related control, the pump displacement is adjusted in proportion to the pilot pressure applied at port **H5**.

Basic position without pilot signal is $V_{g \max}$, which includes the mechanically depressurized basic position $V_{g \max}$ (see type code digit 08).

- ▶ Maximum permissible pilot pressure $p_{St \max} = 100\text{bar}$
- ▶ Control from $V_{g \max}$ to $V_{g \min}$
With increasing pilot pressure the pump swivels to a smaller displacement.
- ▶ Beginning of control (at $V_{g \max}$) 10bar

The required control power is taken from the working pressure or the external control pressure applied to port **P**. If the pump is to be adjusted at low working pressure, port **P** must have an external control pressure supply of at least 30bar, maximum 50bar.

Notice

If no external control pressure is connected to **P**, the version "Maximum swivel angle ($V_{g \max}$), without external control pressure supply" must be ordered (see type code digit 08, A).

▼ **Characteristic curve H5 (negative)**

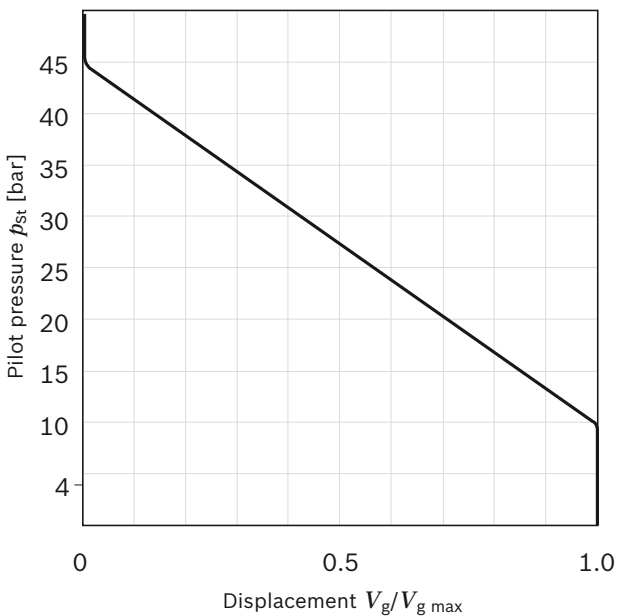

Pilot pressure increase $V_{g \max}$ to $V_{g \min}$: $\Delta p = 35\text{bar}$

▼ **Circuit diagram H5**

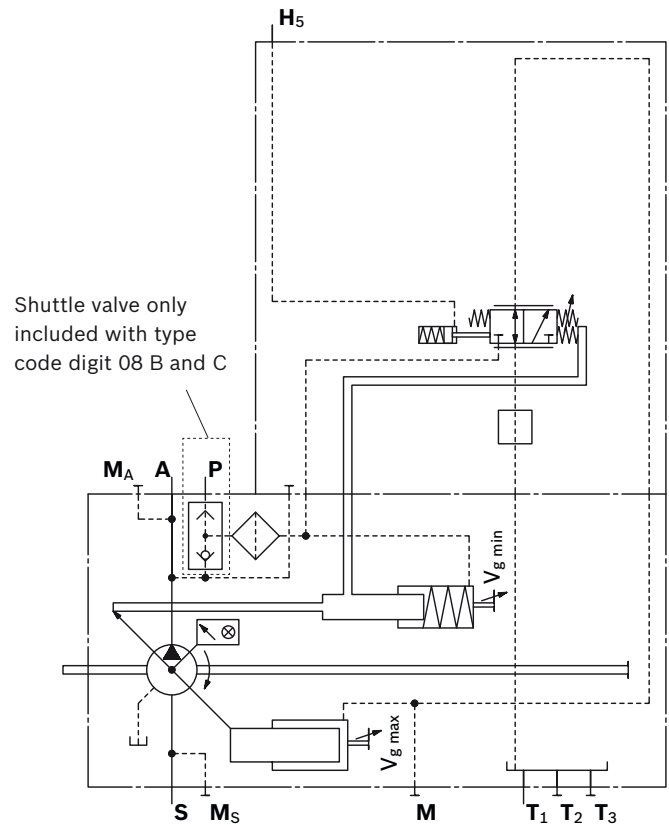

Notice!

The spring feedback in the controller is not a safety device. The controller can stick in an undefined position due to internal contamination (contaminated hydraulic fluid, abrasion or residual contamination from system components). As a result, the flow in the axial piston unit will no longer respond correctly to the operator's specifications. Check whether the application on your machine requires additional safety measures to bring the driven consumer to a safe position (immediate stop). If necessary, make sure these are appropriately implemented.

H6 – Stroke control, hydraulic-proportional, pilot pressure (positive control)

With pilot-pressure related control, the pump displacement is adjusted in proportion to the pilot pressure applied at port **H6**.

Basic position without pilot signal is $V_{g\ min}$, which includes the mechanically depressurized basic position $V_{g\ min}$ (see type code digit 08).

- ▶ Maximum permissible pilot pressure $p_{St\ max} = 100\text{bar}$
- ▶ Control from $V_{g\ min}$ to $V_{g\ max}$
With increasing pilot pressure the pump swivels to a bigger displacement.
- ▶ Beginning of control (at $V_{g\ min}$) 10bar.

The required control power is taken from the working pressure or the external control pressure applied to port **P**. If the pump is to be adjusted from the zero basic setting or from a low working pressure, port **P** must be supplied with an external control pressure of at least 30bar, maximum 50bar.

Notice

If no external control pressure is connected to **P**, the version "Maximum swivel angle ($V_{g\ max}$), without external control pressure supply" must be ordered (see type code digit 08, A).

▼ **Circuit diagram H6**

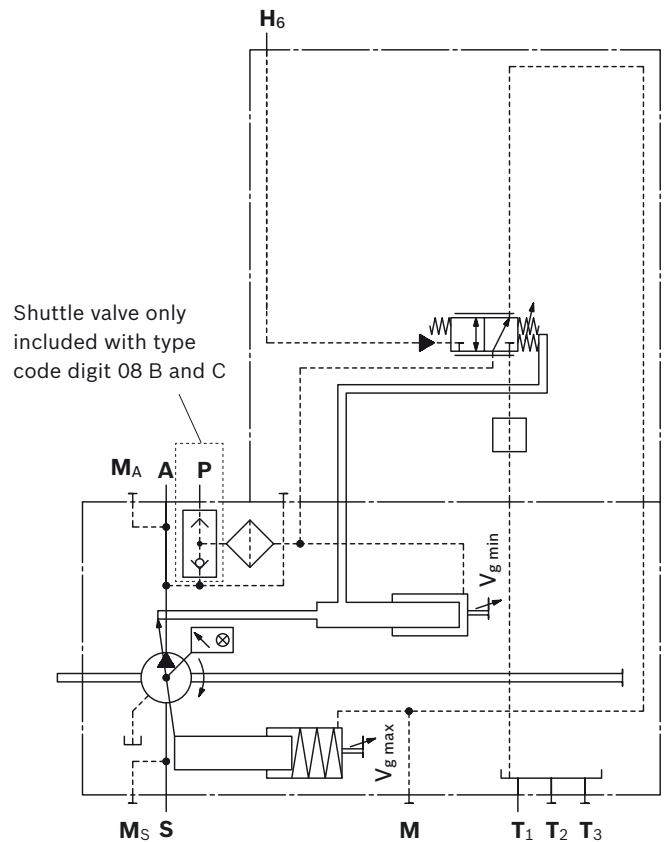

▼ **Characteristic curve H6 (positive)**

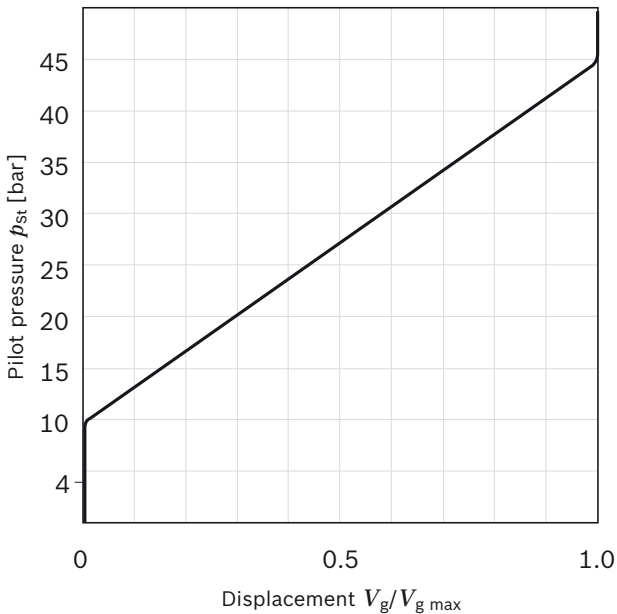

Pilot pressure increase $V_{g\ min}$ to $V_{g\ max}$: $\Delta p = 35\text{bar}$

Notice!

The spring feedback in the controller is not a safety device. The controller can stick in an undefined position due to internal contamination (contaminated hydraulic fluid, abrasion or residual contamination from system components). As a result, the flow in the axial piston unit will no longer respond correctly to the operator's specifications. Check whether the application on your machine requires additional safety measures to bring the driven consumer to a safe position (immediate stop). If necessary, make sure these are appropriately implemented.

Pressure controller

DR – Pressure controller with one-sided swiveling, fixed setting

The pressure controller limits the maximum pressure at the pump outlet within the control range of the variable pump. The variable pump only supplies as much hydraulic fluid as is required by the consumers. If the working pressure exceeds the pressure command value at the pressure valve, the pump will regulate to a smaller displacement to reduce the control differential.

- ▶ Basic position in depressurized state: $V_{g \max}$
- ▶ Setting range for pressure control 50 to 350bar, standard is 350bar.

▼ Characteristic curve DR

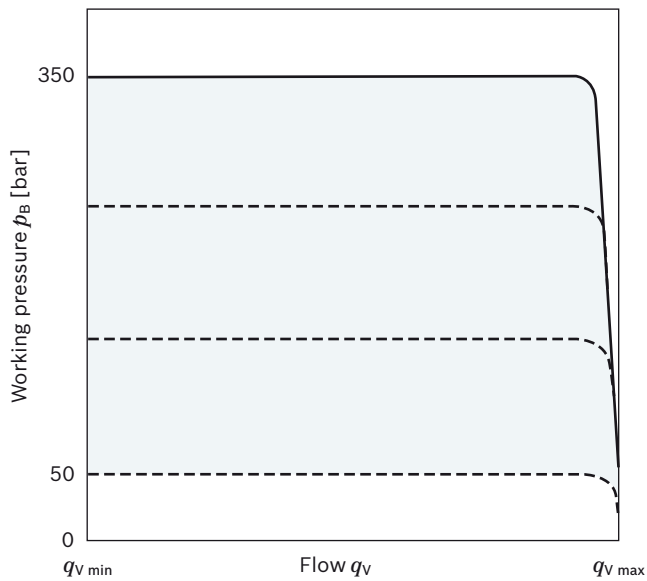

▼ Circuit diagram DR

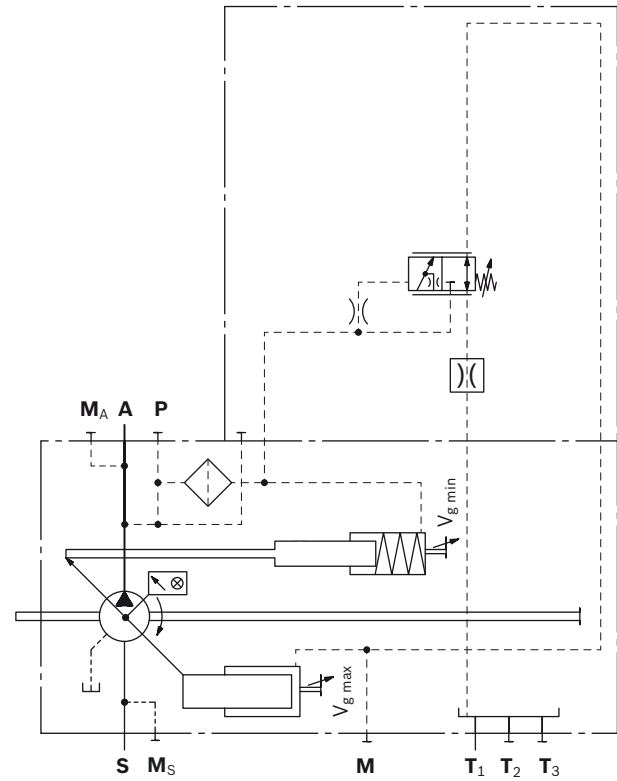

DRSO – Pressure controller with load-sensing

The load-sensing controller works as a load-pressure controlled flow controller and adjusts the displacement of the pump to the volume required by the consumer. The flow of the pump is then dependent on the cross section of the external metering orifice (1), which is located between the pump and the consumer. Below the setting of the pressure controller and within the control range of the pump, the flow is not dependent on the load pressure.

The metering orifice is usually a separately located load-sensing directional valve (control block). The position of the directional valve spool determines the opening cross-section of the metering orifice and thus the flow of the pump.

The load-sensing controller compares the pressure upstream the metering orifice to the one downstream the orifice and keeps the pressure drop (differential pressure Δp) occurring here and thus the flow constant. If the differential pressure Δp at the metering orifice rises, the pump is swiveled back (toward $V_{g \text{ min}}$). If the differential pressure Δp drops, the pump is swiveled out (toward $V_{g \text{ max}}$) until equilibrium at the metering orifice is restored.

$$\Delta p_{\text{metering orifice}} = p_{\text{pump}} - p_{\text{consumer}}$$

- ▶ Setting range for Δp 14bar to 30bar (please state in plain text)
- ▶ Standard setting 14bar

The stand-by pressure in zero-stroke operation (metering orifice closed) is slightly higher than the Δp setting.

▼ **Characteristic curve DRSO**

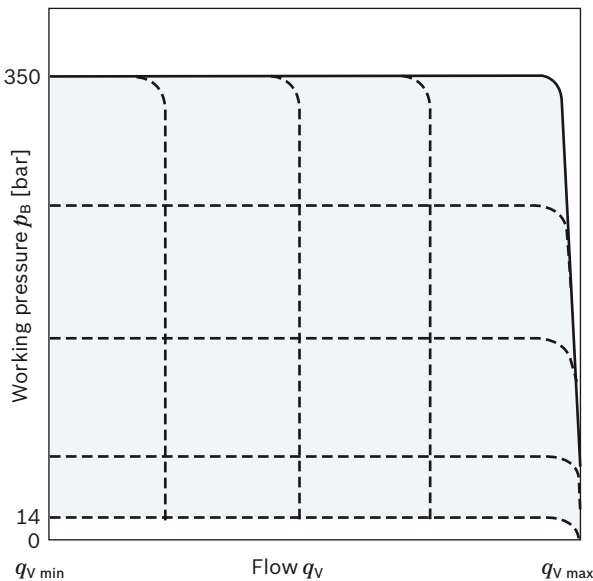

When ordering, state in plain text:

- ▶ Pressure setting p [bar] at pressure controller DR
- ▶ Differential pressure Δp [bar] at load-sensing controller S0

▼ **Circuit diagram DRSO**

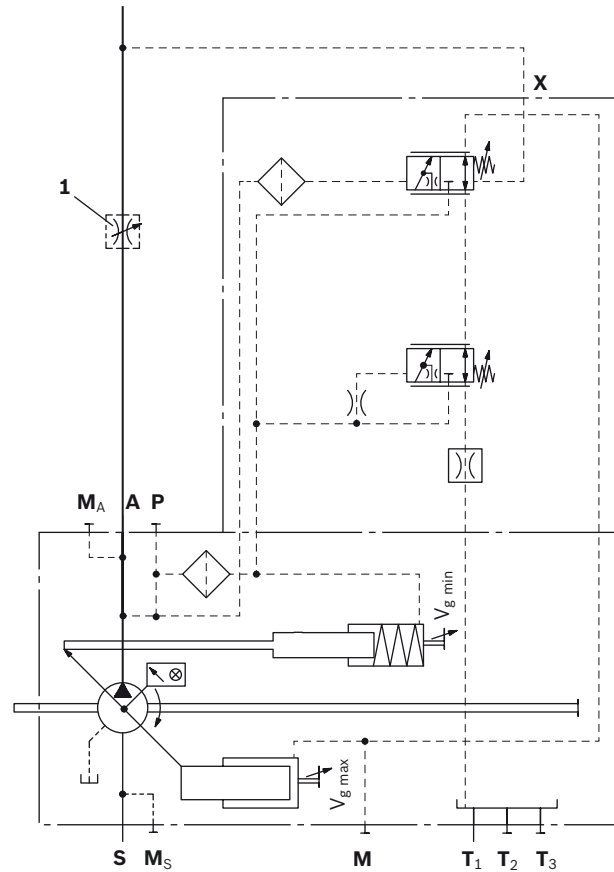

1 The metering orifice (control block) is not included in the scope of delivery.

DG – Pressure controller with one-sided deflection, hydraulically remote controlled (positive control)

The remote controlled pressure controller has a fixed setting Δp value. A separately connected pressure relief valve at port **X** (1) enables the pressure controller to be remote controlled.

- ▶ Setting range Δp 14 to 25bar
- ▶ Recommended value 20bar (standard)
- ▶ Control volume at **X**: approx. 1.6l/min (static) at Δp 20bar

In addition a separately configured 2/2 directional valve (2) can be operated to start the pump with low working pressure (standby pressure).

Both functions can be used individually or in combination (see circuit diagram).

The external valves are not included in the scope of delivery.

As a separate pressure relief valve (1) we recommend:

- ▶ DBD.6, see data sheet 25402
- ▶ DBETA-6X, see data sheet 29262

Note for setting remote-controlled pressure control

The setting value for the external pressure relief valve plus the differential pressure value at the pressure control valve determines the level of pressure control.

Example:

- ▶ External pressure relief valve 330bar
- ▶ Differential pressure on pressure control valve 20bar
- ▶ resulting pressure control of 330 + 20 = 350bar

▼ **Characteristic curve DG**

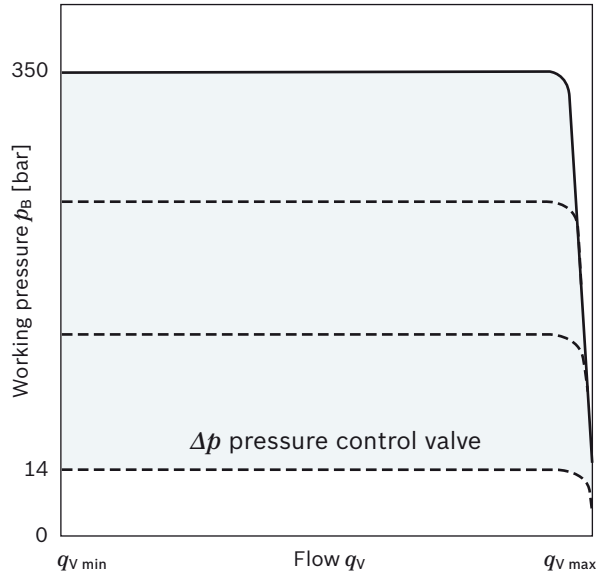

For function and description of pressure control DR, see page 24

▼ **Circuit diagram DG**

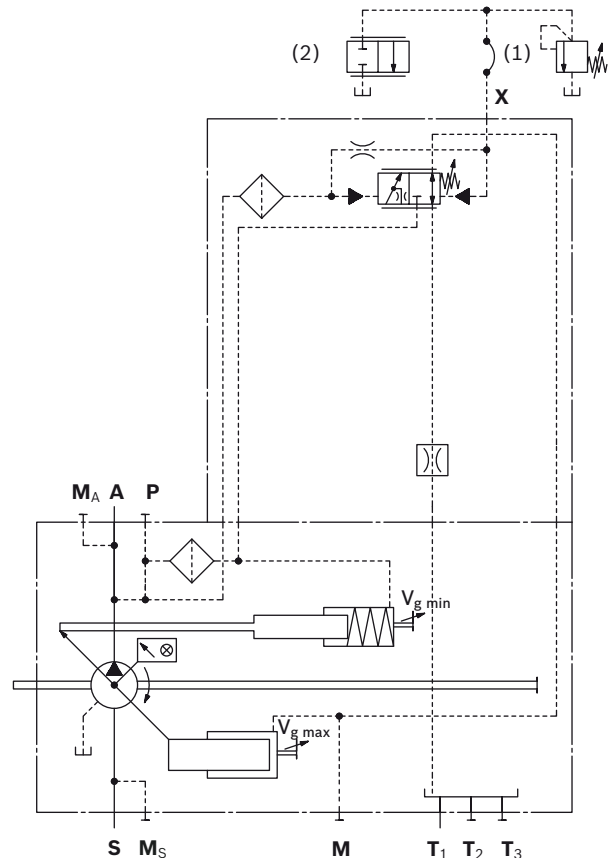

- 1 Pressure relief valve (not included in the scope of delivery)
- 2 2/2 directional valve (not included in the scope of delivery)

DP – Pressure controller with one-side swiveling, for parallel operation (positive control)

The pressure controller DP is suitable for pressure control of several A15VSO or A15VLO axial piston pumps in parallel operation pumping into a common pressure line.

The pressure control has a pressure increase of approx. 7bar from $q_{v \max}$ to $q_{v \min}$. The pump regulates therefore to a pressure dependent swivel angle. This means a parallel or synchronous control behavior of several pumps.

The DP controller has a fixed Δp value which is overridden, depending on the swivel angle. Reference operating point is zero stroke.

Setting value Δp at zero stroke 27bar.

With the externally installed pressure relief valve (1) the nominal pressure command value of all pumps connected to the system is adjusted to the same value.

Setting range from 50 to 350bar.

Control current for DP: approx. 1.9l/min (static) at Δp 27bar.

Each pump can be individually unloaded from the system by a separately installed 2/2 directional valve (2) and set to a standby position.

The check valve in the working line (port **A**) is generally to be provided by the customer. The check valve in the control line (port **DP**) is included in the scope of delivery. The external valves are not included in the scope of delivery.

As a separate pressure relief valve (1) we recommend: DBD.6 (manual actuation), see RE 25402

Characteristic curve DP

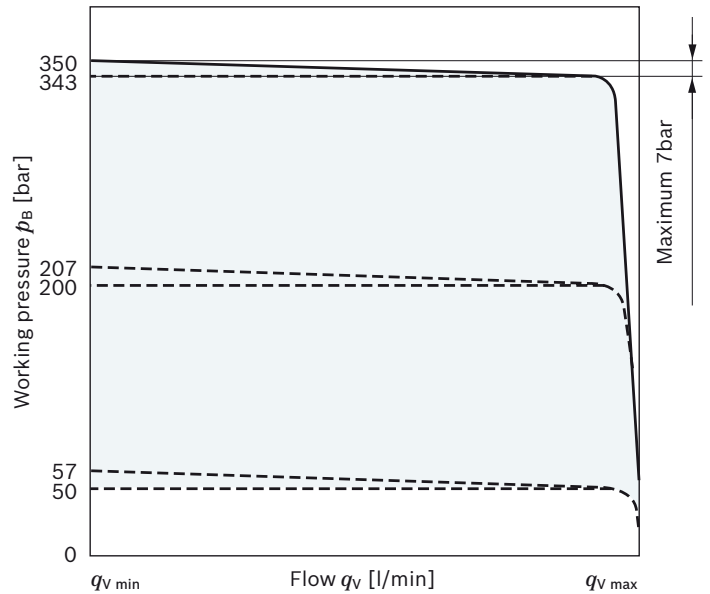

▼ Circuit diagram DP

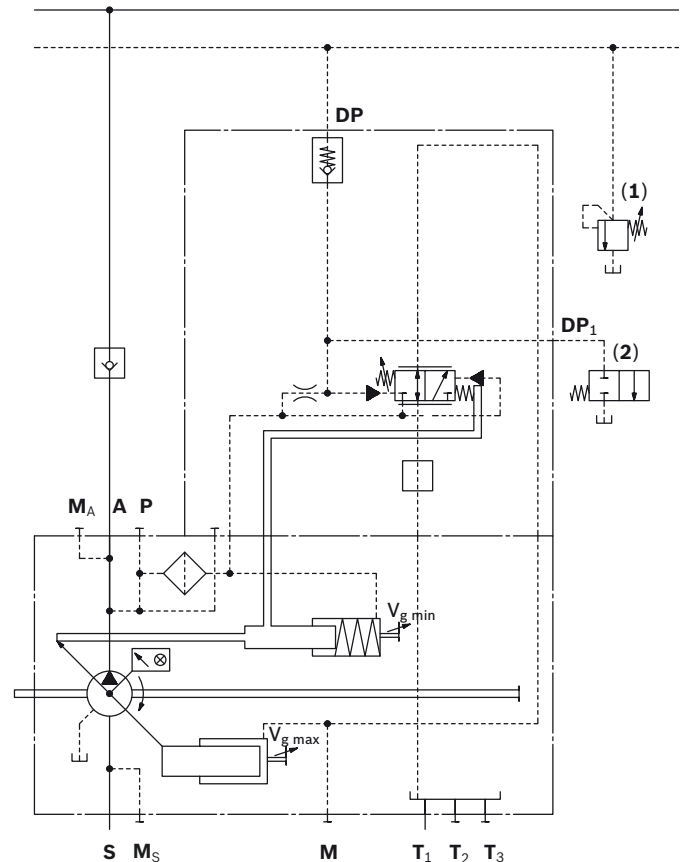

- 1 Pressure relief valve
(not included in the scope of delivery)
- 2 2/2 directional valve
(not included in the scope of delivery)

DGV2 – With integrated pressure relief valve and electric 2/2 directional seat valve (de-energized standby)

The remote controlled pressure controller has a fixed setting Δp value. A pressure relief valve (pilot valve) integrated in the control valve allows for a fixed pressure control with switch-off through to standby = Δp value due to the integrated electric 2/2 directional seat valve.

- ▶ Setting range Δp 14bar to 25bar
- ▶ Recommended value 20bar (standard)
- ▶ Setting range for pressure control is 60bar to 350bar
- ▶ Standard is 350bar

When ordering, state in plain text:

- ▶ Differential pressure Δp in bar
- ▶ Pressure setting p in bar
(working pressure on port **A**)

Technical data, solenoid	DGV2
Voltage	24V \pm 10%
Current	900mA
Nominal resistance (at 20-25°C)	28.2 Ω
Power consumption	20W
Type of protection: see connector version page 63	

▼ **Circuit diagram DGV2**

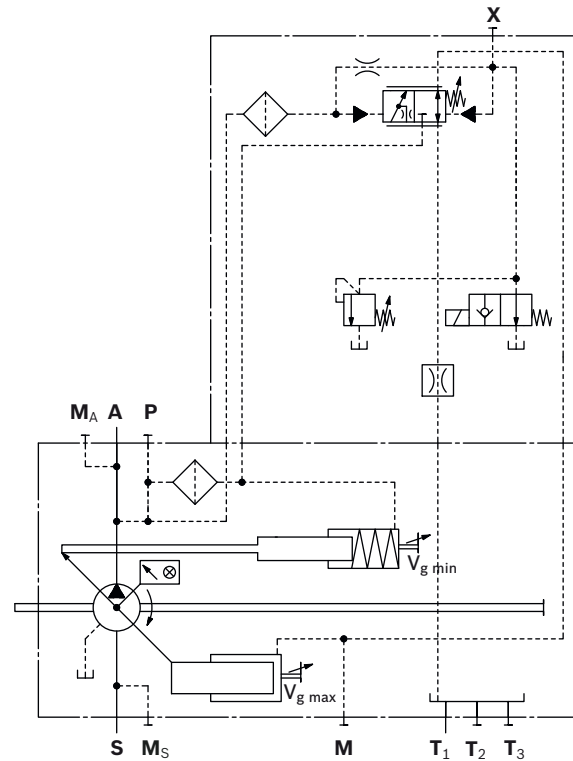

▼ **Characteristic curve DGV2**

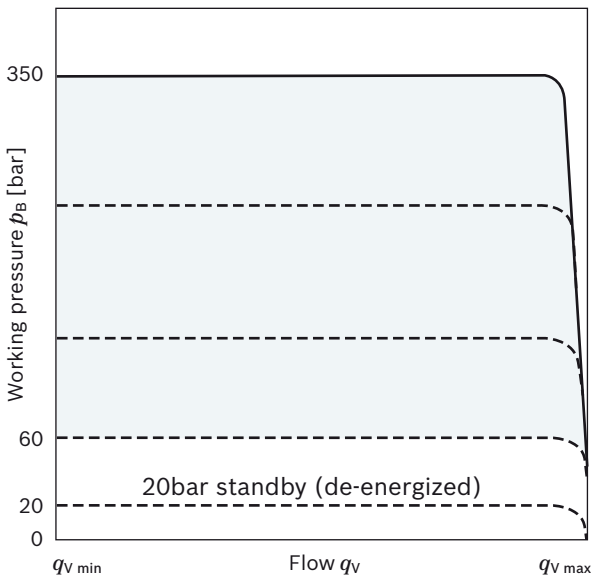

DGT6 – With integrated pilot control valve, electric-proportional override (positive control)

The remote controlled pressure controller has a fixed-setting Δp value. An electric pressure relief valve (pilot valve) integrated in the control valve enables remote pressure control.

- ▶ Fixed value at Δp 14bar.

When ordering, state in plain text:

- ▶ Maximum pressure p_{max} [bar] (pressure on port **A**) with 1200mA current.

Pilot valve T6

The electric-proportional pressure relief valve is directly controlled with a positive control as cartridge version (see data sheet 18139-07).

The following pressure settings are available:

250, 315 and 350bar plus 14bar Δp .

- ▶ Standard is 350bar

When ordering, the correct pressure value is selected by Rexroth.

Notes and explanations for the DG controller can be found on page 26.

▼ **Characteristic curve T6**

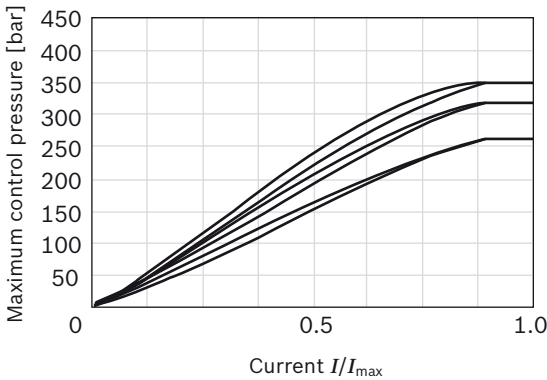

Technical data, solenoid	T6
Voltage	24V
Control current	
Minimum pressure p_{min}	0mA
Maximum pressure p_{max}	1200mA
Maximum rated current	1200mA
Nominal resistance (at 20°C)	4.8Ω
Dither frequency	200Hz
Duty cycle	100%
Type of protection: see connector version page 63	

The following electronic control units and amplifiers are available for controlling the proportional solenoids:

Amplifier card	Data sheet
VT-SSPA1	30116
Analog amplifier RA	95230

▼ **Circuit diagram DGT6**

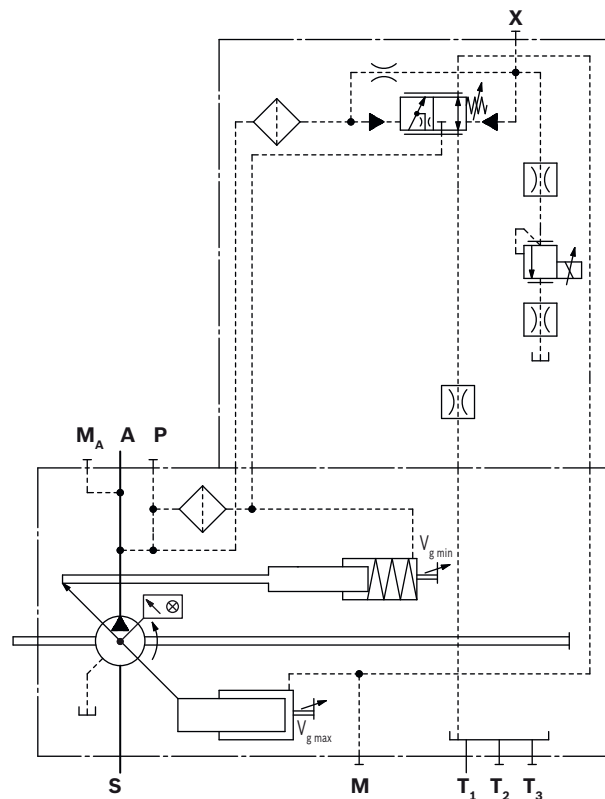

DGT8 – With integrated pilot control valve, electric-proportional override (negative control)

The remote controlled pressure controller has a fixed-setting Δp value. An electric pressure relief valve (pilot valve) integrated in the control valve enables remote pressure control.

- ▶ Fixed value at Δp 14bar.

When ordering, state in plain text:

- ▶ Maximum pressure p_{max} [bar] (pressure on port **A**) with 0mA current.

Pilot valve T8

The electric-proportional pressure relief valve is directly controlled with a negative control as cartridge version (see data sheet 18139-07).

The following pressure settings are available:

250, 315 and 350bar plus 14bar Δp .

- ▶ Standard is 350bar

When ordering, the correct pressure value is selected by Rexroth.

Notes and explanations for the DG controller can be found on page 26.

▼ **Characteristic curve T8**

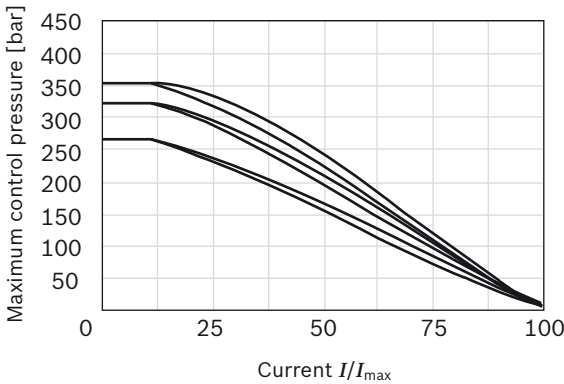

Technical data, solenoid	T8
Voltage	24V
Control current	
Maximum pressure p_{max}	0mA
Minimum pressure p_{min}	1200mA
Maximum rated current	1200mA
Nominal resistance (at 20°C)	4.8Ω
Dither frequency	200Hz
Duty cycle	100%
Type of protection: see connector version page 63	

The following electronic control units and amplifiers are available for controlling the proportional solenoids:

Amplifier card	Data sheet
VT-SSPA1	30116
Analog amplifier RA	95230

▼ **Circuit diagram DGT8**

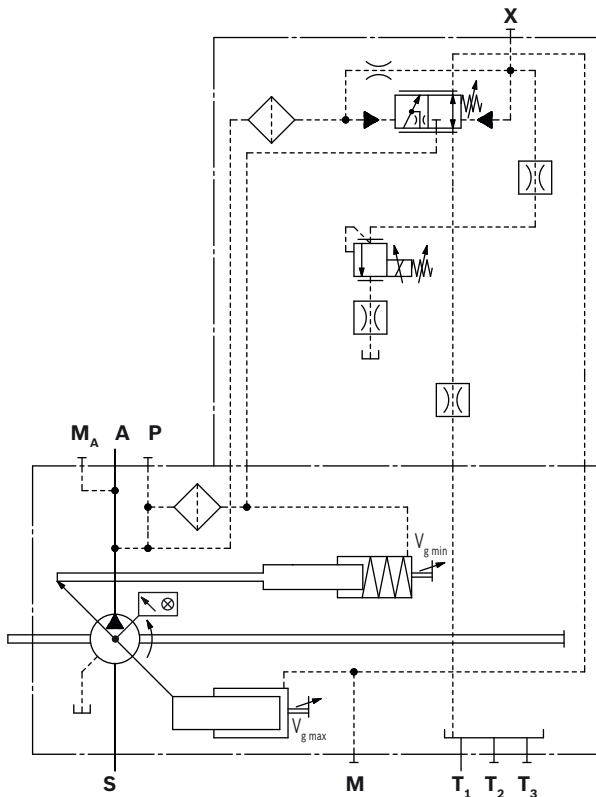

Dimensions, size 110

LRDRS0 – Power controller with pressure controller, load-sensing and with electric swivel angle sensor

Clockwise rotation

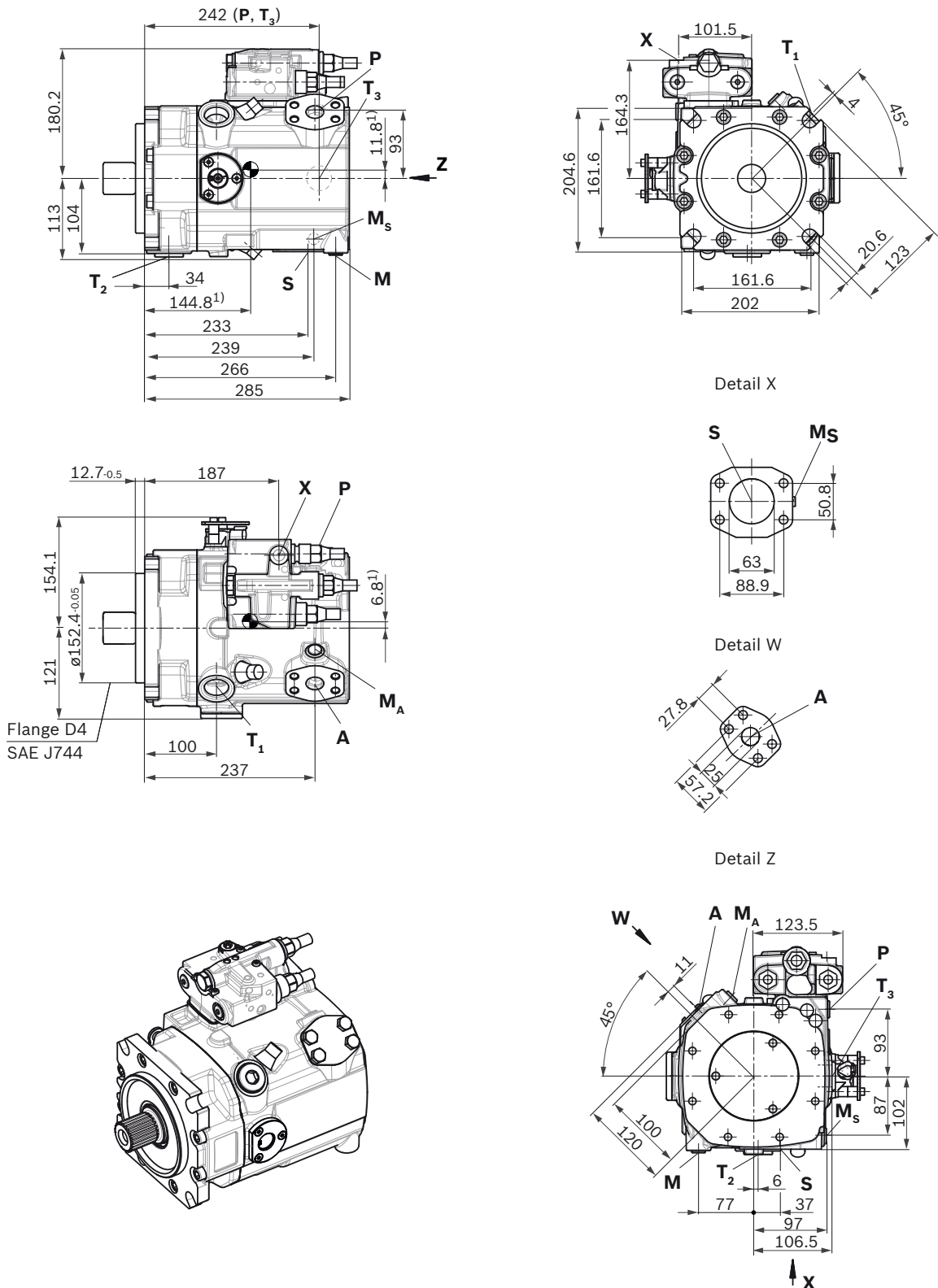

¹⁾ Center of gravity

▼ **Splined shaft DIN 5480**

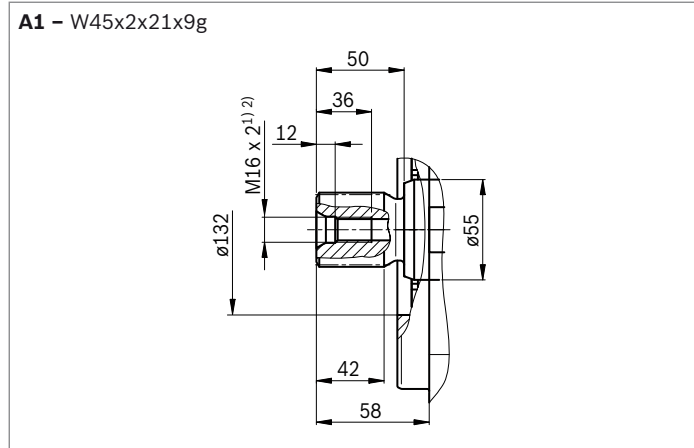

▼ **Parallel keyed shaft DIN 6885**

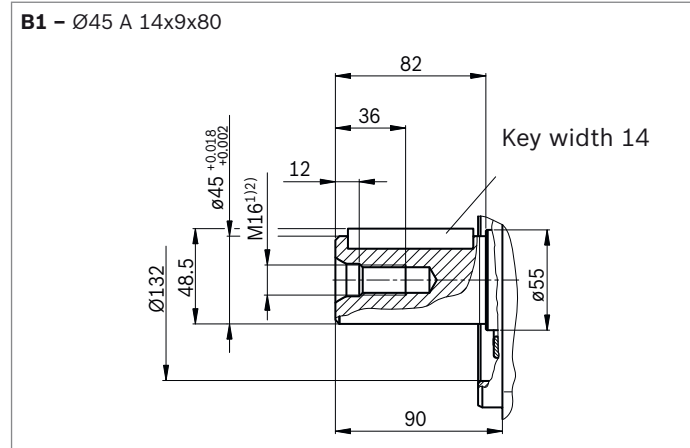

Ports		Standard	Size ²⁾	$p_{\max \text{ abs}}$ [bar] ³⁾	State ⁷⁾
A	Working port Fastening thread	SAE J518 ⁴⁾ DIN 13	1 in M12 x 2; 18 deep	420	O
S	Suction port (without charge pump) Fastening thread	SAE J518 ⁴⁾ DIN 13	2 1/2 in M12 x 2; 18 deep	30	O
T₁	Drain port	ISO 6149 ⁵⁾	M33 x 2; 19 deep	10	O ⁶⁾
T₂	Drain port	ISO 6149 ⁵⁾	M33 x 2; 19 deep	10	X ⁶⁾
T₃	Drain port	ISO 6149 ⁵⁾	M33 x 2; 19 deep	10	X ⁶⁾
CR	Pilot signal (CR only)	ISO 6149	M14 x 1.5; 11.5 deep	420	O
PR	Pilot signal (PR only)	ISO 6149	M14 x 1.5; 11.5 deep	420	O
H3 to H6	Pilot signal (only on H3, H4, H5 and H6)	ISO 6149	M14 x 1.5; 11.5 deep	100	O
DP	Pilot pressure (only on DP)	DIN 3853	S8 form W; 8 deep	420	O
DP₁	Measuring port pilot signal (DP)	ISO 6149	M14 x 1.5; 11.5 deep	420	X
X	Pilot signal	ISO 6149 ⁵⁾	M14 x 1.5; 11.5 deep	420	O
M	Control pressure measuring	ISO 6149 ⁵⁾	M14 x 1.5; 12 deep	420	X
M_A	Measuring pressure A	ISO 6149 ⁵⁾	M14 x 1.5; 12 deep	420	X
M_S	Suction pressure measuring	ISO 6149 ⁵⁾	M14 x 1.5; 12 deep	30	X
P	External control pressure (Type code digit 8 version B or C = with external control pressure supply)	ISO 6149 ⁵⁾	M14 x 1.5; 11.5 deep	50	O
	Port P is without function (Type code digit 8 version A = without external control pressure supply)	ISO 6149 ⁵⁾	M18 x 1.5; 14.5 deep	420	X

1) Center bore according to DIN 332 (thread according to DIN 13)

2) Observe the notes in the instruction manual concerning the maximum tightening torques.

3) Depending on the application, momentary pressure peaks can occur. Keep this in mind when selecting measuring devices and fittings.

4) Metric fastening thread is a deviation from standard.

5) The countersink may be deeper than specified in the standard.

6) Depending on installation position, **T₁**, **T₂** or **T₃** must be connected (see also Installation instructions on pages 64 and 65).

7) O = Must be connected (comes plugged)

X = Plugged (in normal operation)

▼ **LR - Power controller, fixed setting**

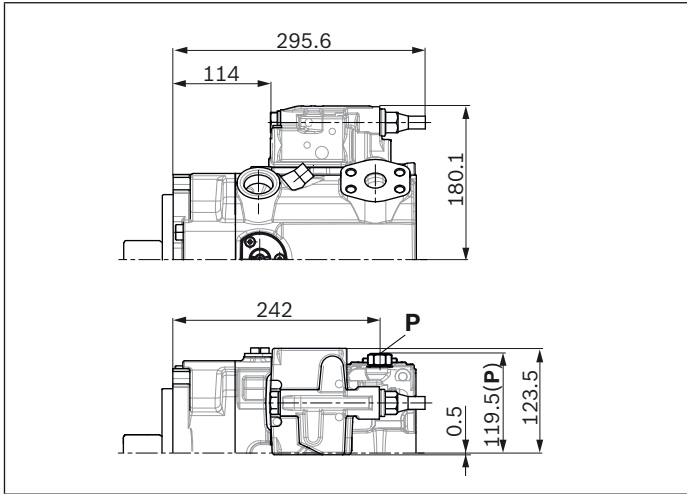

▼ **L4 - Power controller, electric-proportional override**

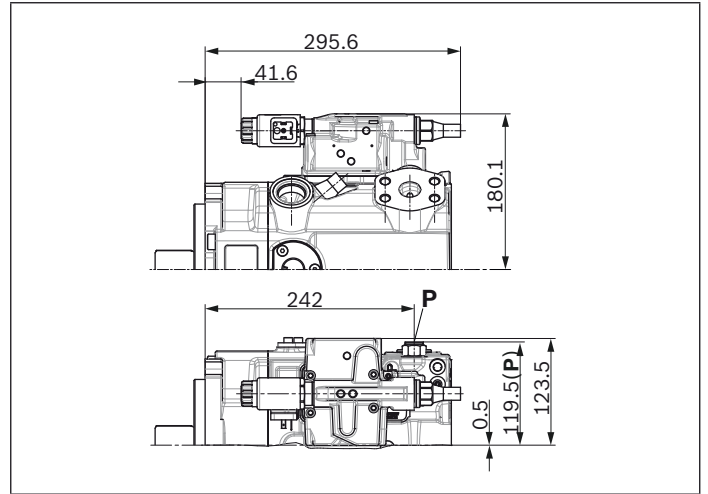

▼ **CR - Power controller, hydraulic-proportional override, high pressure, with stop**

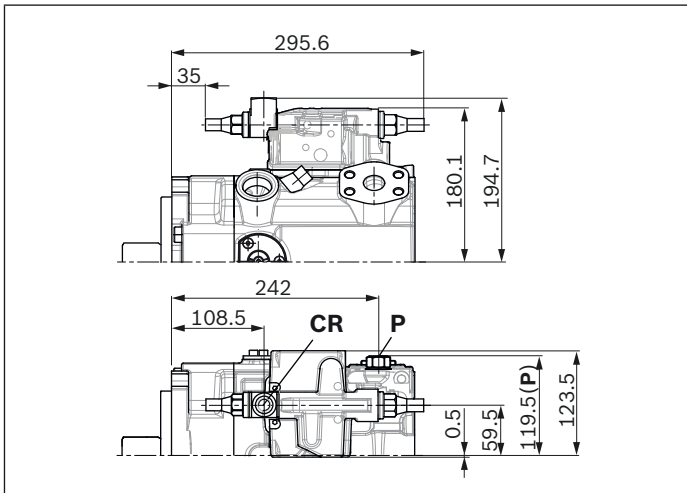

▼ **PR - Power controller, hydraulic-proportional override, high pressure, without stop**

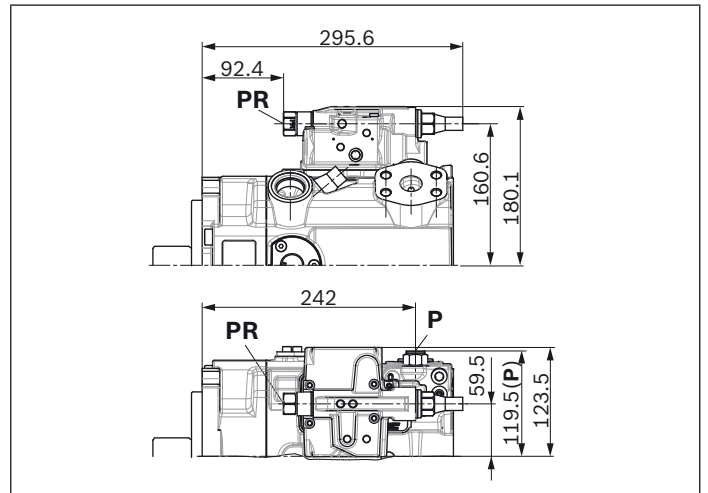

▼ **E2/E6 - Stroke control electric-proportional**

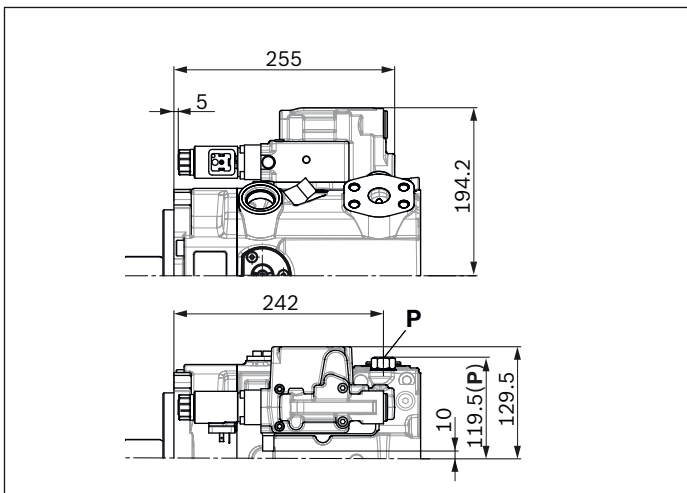

▼ **H3/4/5/6 - Stroke control, hydraulic prop., pilot pressure**

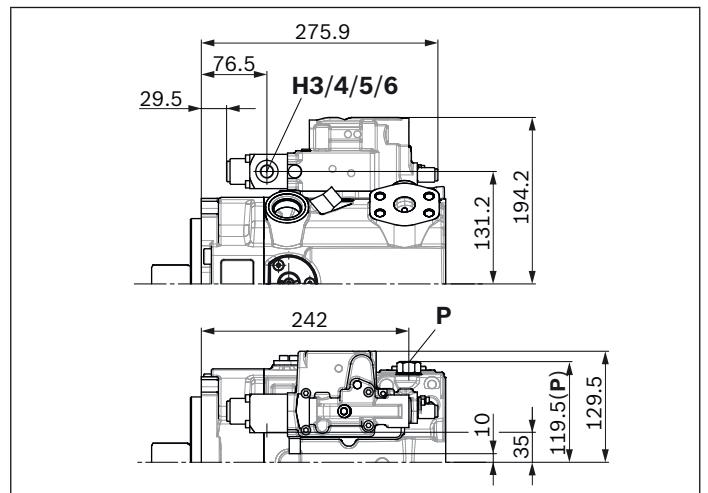

Notice

All controllers described with shuttle valve in **P**
 (some contrary to standard as per type code digit 08)

▼ **DR – Pressure controller, fixed setting**

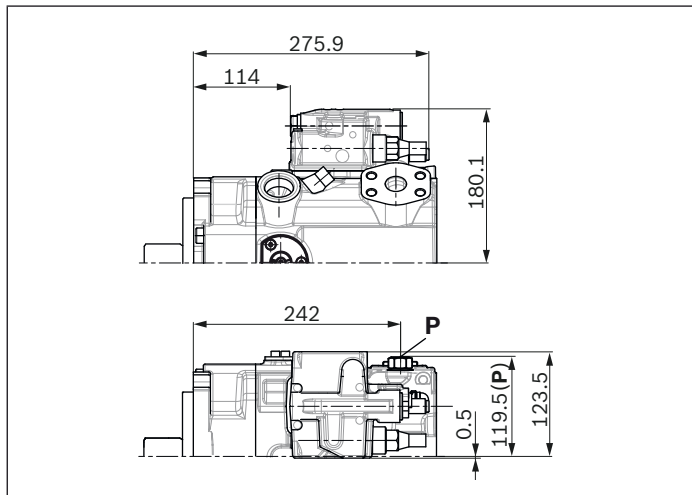

▼ **LRDRS0 – Power controller with pressure controller and load-sensing, fixed setting**

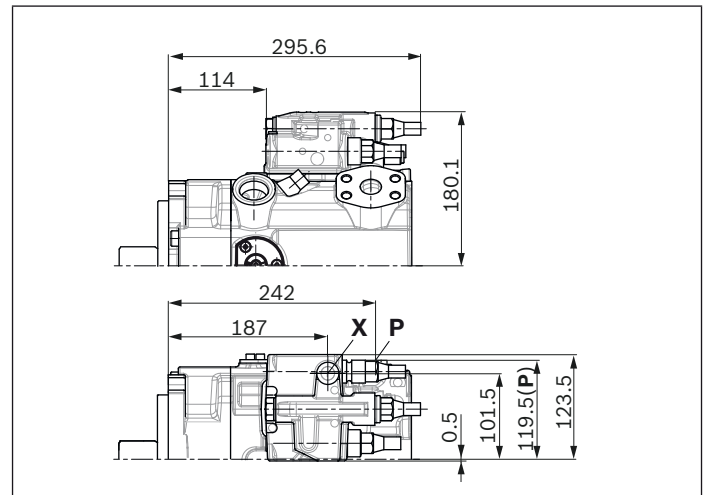

▼ **DG – Pressure controller, hydraulic, remote controlled**

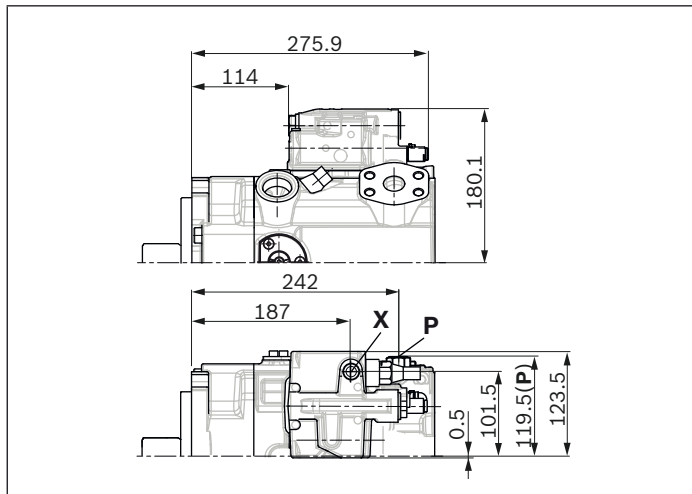

▼ **DP – Pressure controller, for parallel operation**

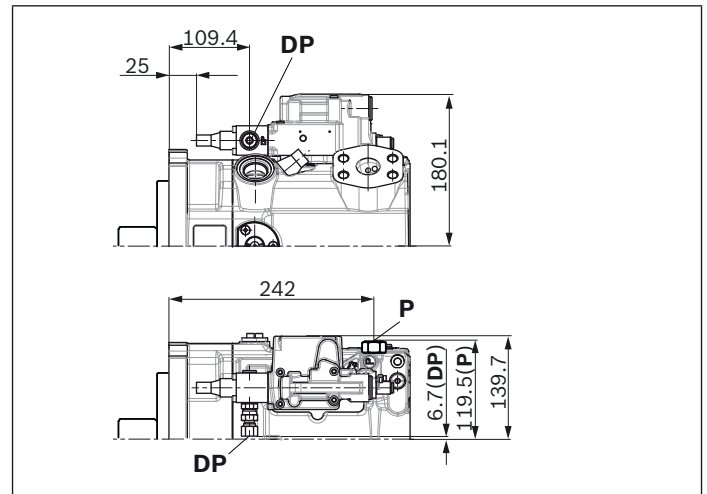

▼ **DGT6/DGT8 – With integrated pilot control valve, electric-proportional override**

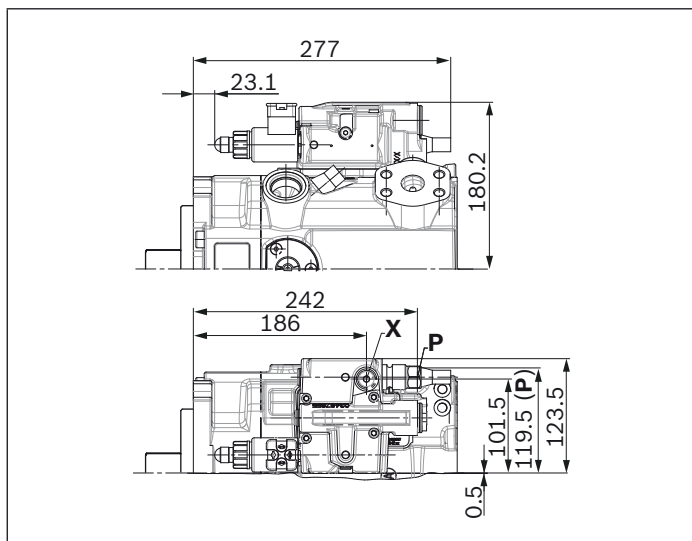

▼ **DGV2 – Electric directional valve and pressure relief valve mounted (only in combination with DG)**

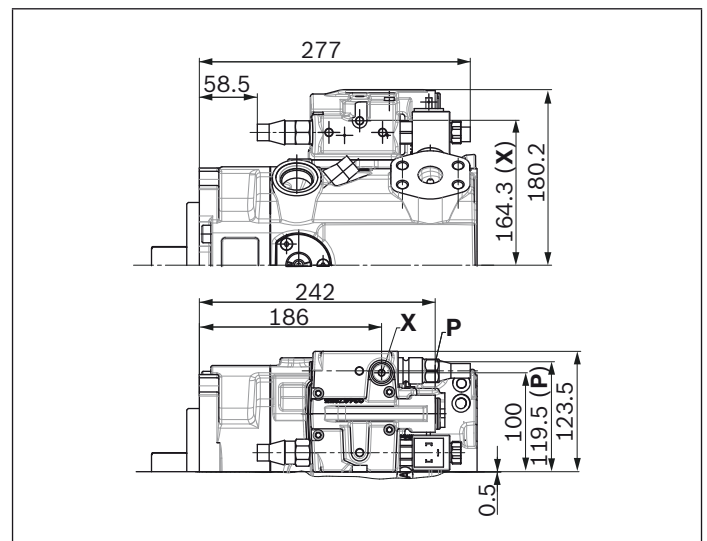

Notice

All controllers described with shuttle valve in **P**
(some contrary to standard as per type code digit 08)

Dimensions, size 145

LRDRS0 – Power controller with pressure controller, load-sensing and with electric swivel angle sensor

Without charge pump, clockwise rotation

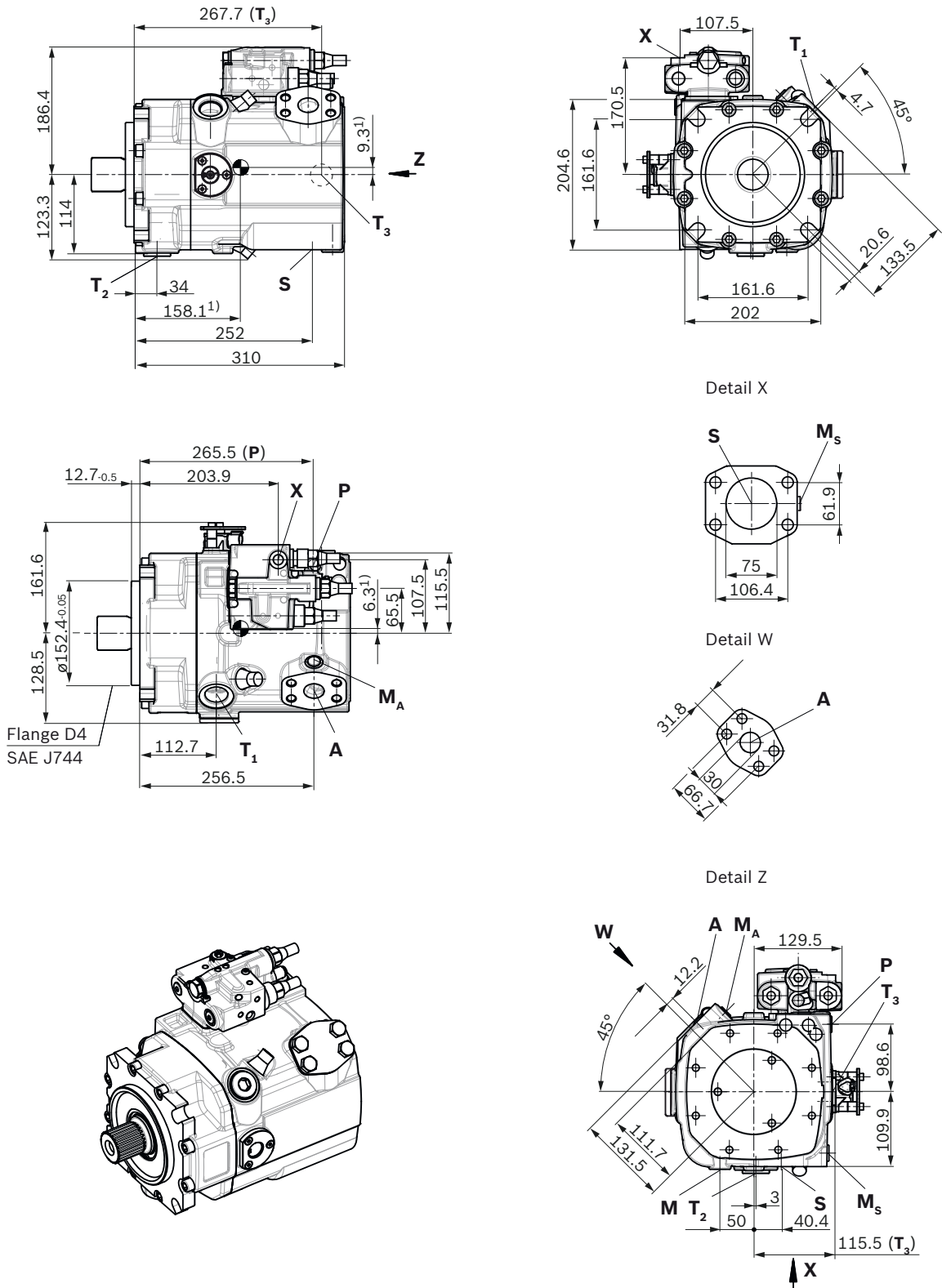

1) Center of gravity

LRDRS0 – Power controller with pressure controller, load-sensing and with electric swivel angle sensor

With charge pump, clockwise rotation

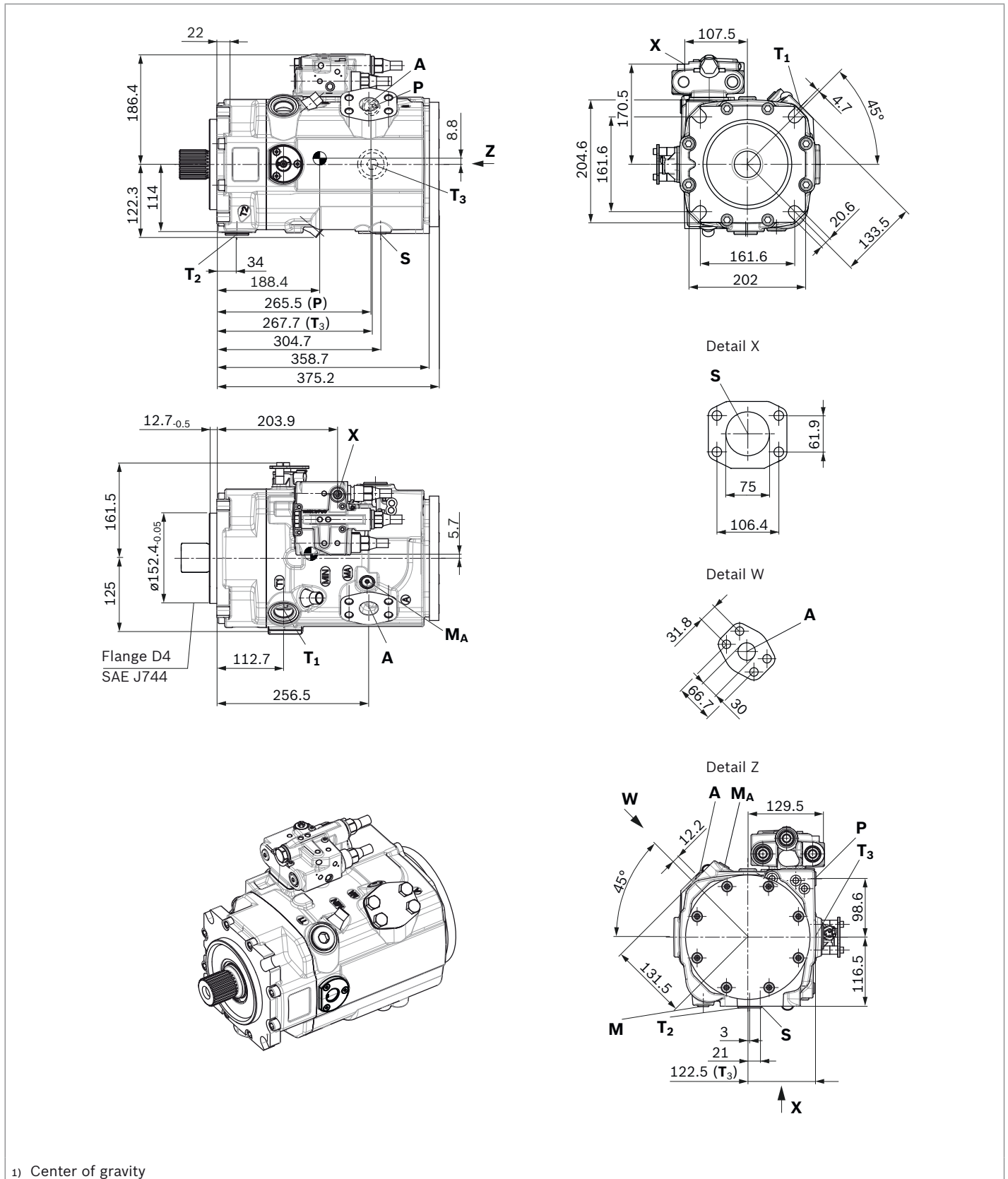

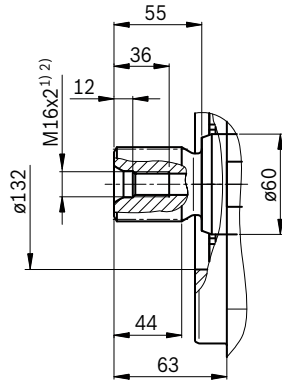
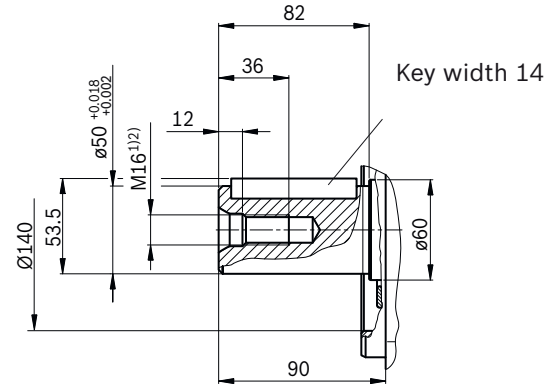
▼ **Splined shaft DIN 5480****A2** – W50x2x24x9g▼ **Parallel keyed shaft DIN 6885****B2** – Ø50 A 14x9x80

Ports	Standard	Size ²⁾	$p_{\max \text{ abs}}$ [bar] ³⁾	State ⁷⁾
A	Working port Fastening thread	SAE J518 ⁴⁾ DIN 13	1 1/4 in M14 x 2; 22 deep	420 O
S	Suction port (without charge pump) Fastening thread	SAE J518 ⁴⁾ DIN 13	3 in M16 x 2; 24 deep	30 O
S	Suction port (with charge pump) Fastening thread	SAE J518 ⁶⁾ DIN 13	3 in M16 x 2; 24 deep	2 O
T₁	Drain port	ISO 6149 ⁵⁾	M33 x 2; 19 deep	10 O ⁶⁾
T₂	Drain port	ISO 6149 ⁵⁾	M33 x 2; 19 deep	10 X ⁶⁾
T₃	Drain port	ISO 6149 ⁵⁾	M33 x 2; 19 deep	10 X ⁶⁾
CR	Pilot signal (CR only)	ISO 6149	M14 x 1.5; 11.5 deep	420 O
PR	Pilot signal (PR only)	ISO 6149	M14 x 1.5; 11.5 deep	420 O
H3 to H6	Pilot signal (only on H3, H4, H5 and H6)	ISO 6149	M14 x 1.5; 11.5 deep	100 O
DP	Pilot pressure (only on DP)	DIN 3853	S8 form W; 8 deep	420 O
DP₁	Measuring port pilot signal (DP)	ISO 6149	M14 x 1.5; 11.5 deep	420 X
X	Pilot signal	ISO 6149 ⁵⁾	M14 x 1.5; 11.5 deep	420 O
M	Control pressure measuring	ISO 6149 ⁵⁾	M14 x 1.5; 12 deep	420 X
M_A	Measuring pressure A	ISO 6149 ⁵⁾	M14 x 1.5; 12 deep	420 X
M_S	Measuring suction pressure (only A15VSO)	ISO 6149 ⁵⁾	M14 x 1.5; 12 deep	30 X
P	External control pressure (Type code digit 8 version B or C = with external control pressure supply)	ISO 6149 ⁵⁾	M14 x 1.5; 11.5 deep	50 O
	Port P is without function (Type code digit 8 version A = without external control pressure supply)	ISO 6149 ⁵⁾	M18 x 1.5; 14.5 deep	420 X

1) Center bore according to DIN 332 (thread according to DIN 13)

2) Observe the notes in the instruction manual concerning the maximum tightening torques.

3) Depending on the application, momentary pressure peaks can occur. Keep this in mind when selecting measuring devices and fittings.

4) Metric fastening thread is a deviation from standard.

5) The countersink may be deeper than specified in the standard.

6) Depending on installation position, T₁, T₂ or T₃ must be connected (see also Installation instructions on pages 64 and 65).

7) O = Must be connected (comes plugged)

X = Plugged (in normal operation)

▼ **LR – Power controller, fixed setting**

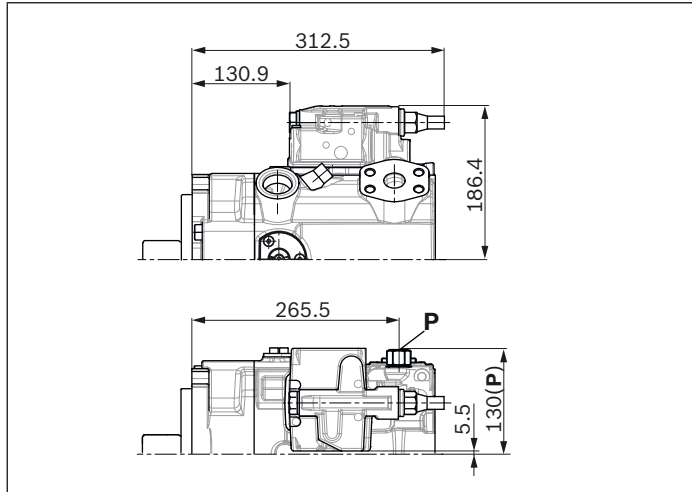

▼ **L4 – Power controller, electric-proportional override**

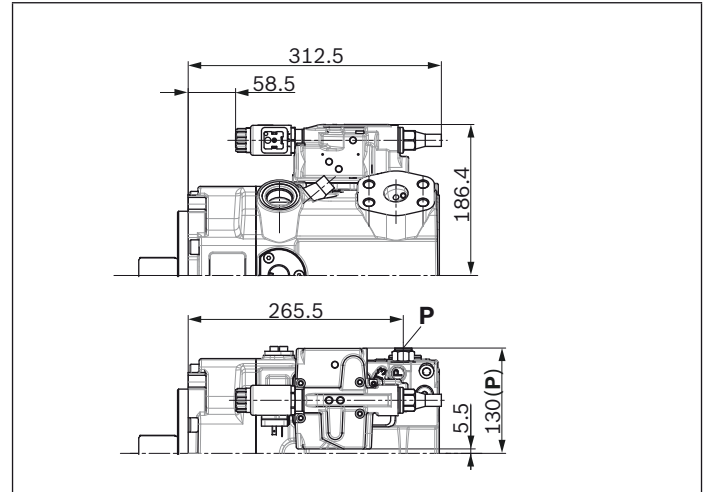

▼ **CR – Power controller, hydraulic-proportional override, high pressure, with stop**

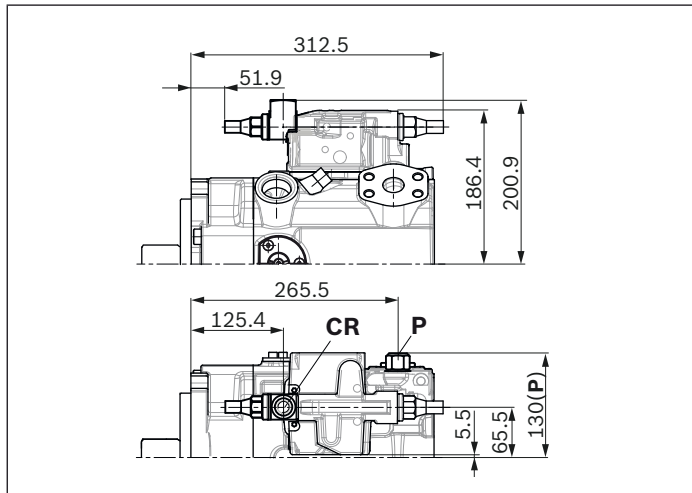

▼ **PR – Power controller, hydraulic-proportional override, high pressure, without stop**

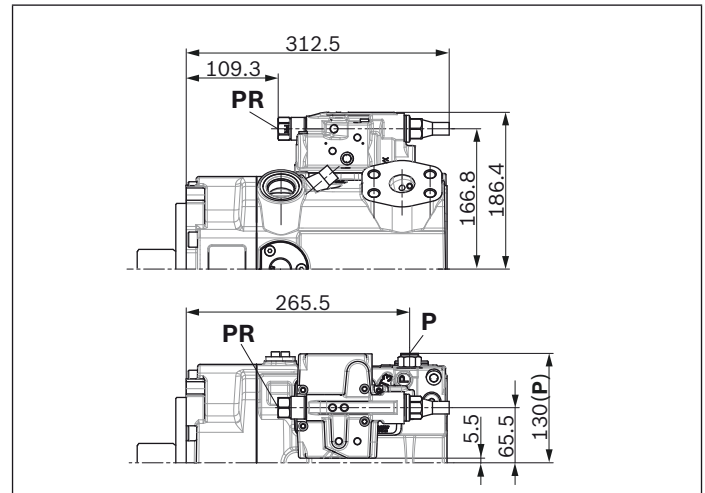

▼ **E2/E6 – Stroke control electric-proportional**

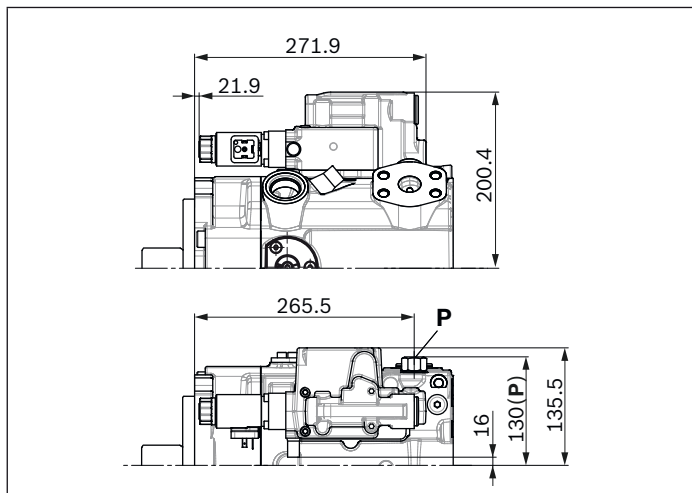

▼ **H3/4/5/6 – Stroke control, hydraulic prop., pilot pressure**

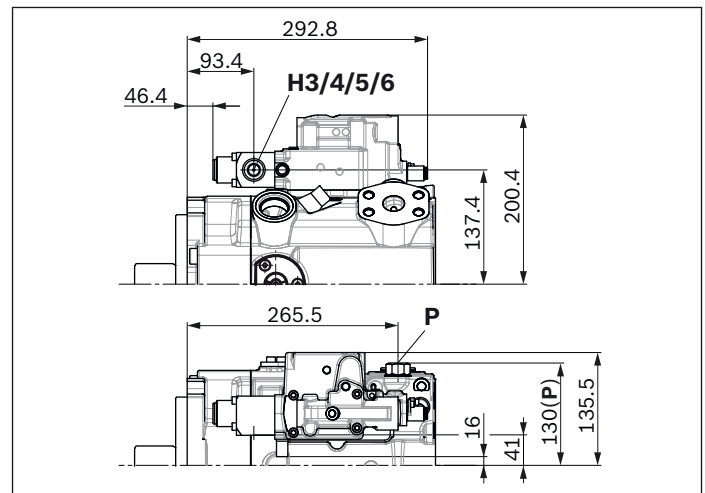

Notice

All controllers described with shuttle valve in **P**
 (some contrary to standard as per type code digit 08)

▼ **DR – Pressure controller, fixed setting**

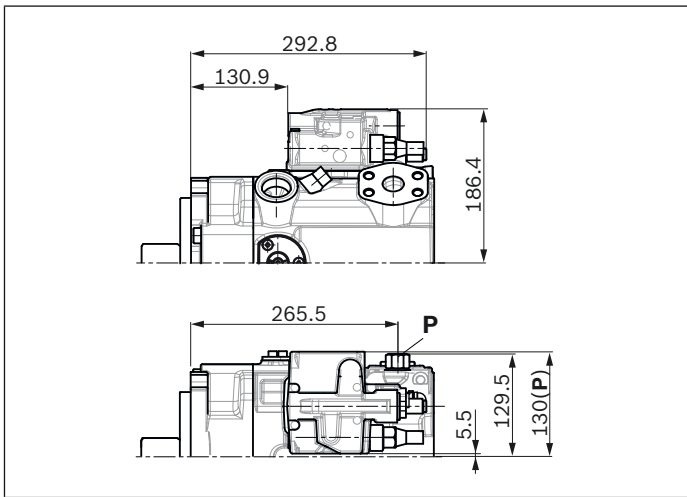

▼ **LRDRS0 – Power controller with pressure controller and load-sensing, fixed setting**

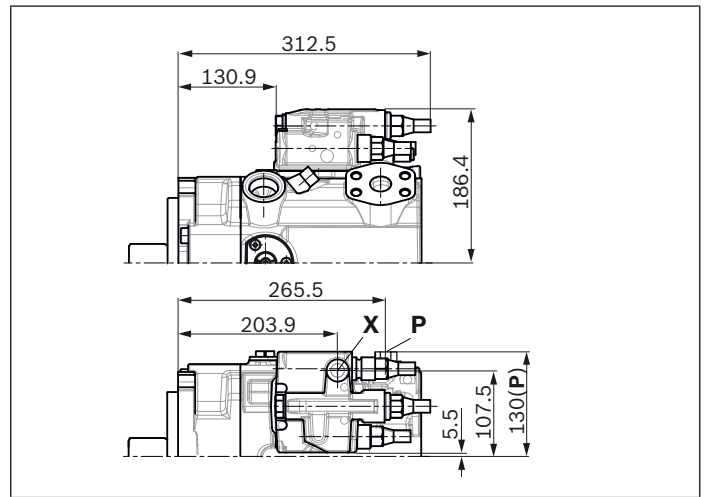

▼ **DG – Pressure controller, hydraulic, remote controlled**

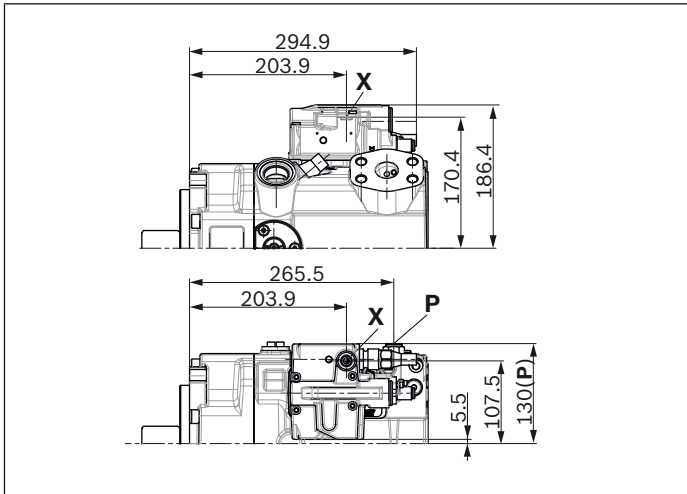

▼ **DP – Pressure controller, for parallel operation**

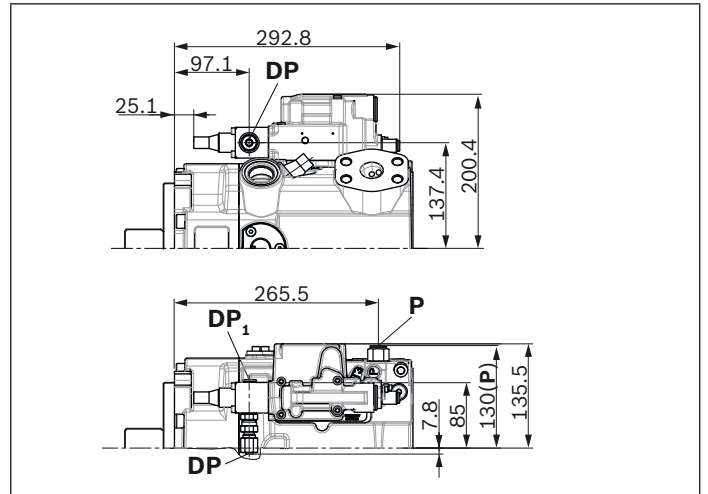

▼ **DGT6/DGT8 – With integrated pilot control valve, electric-proportional override**

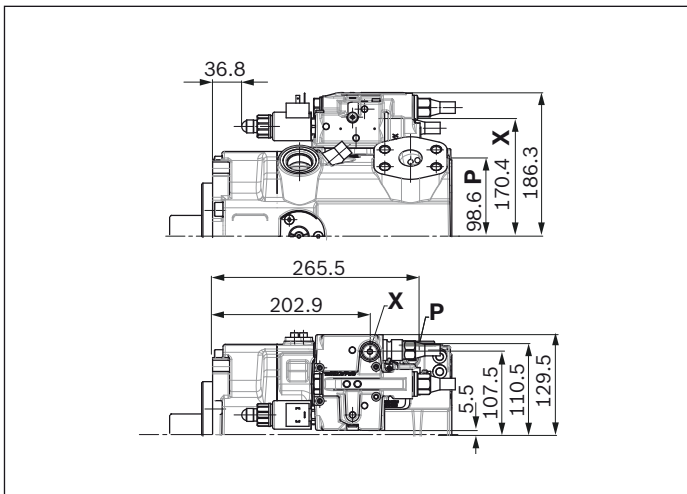

▼ **DGV2 – Electric directional valve and pressure relief valve mounted (only in combination with DG)**

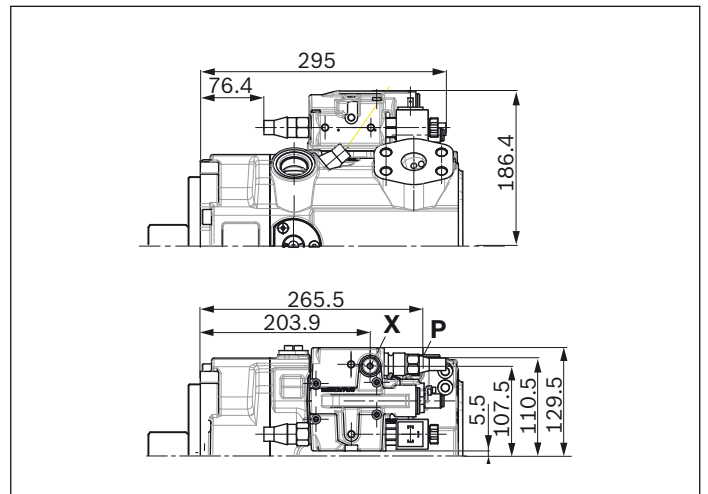

Notice

All controllers described with shuttle valve in **P**
 (some contrary to standard as per type code digit 08)

Dimensions, size 175

LRDRS0 – Power controller with pressure controller, load-sensing and with electric swivel angle sensor

Without charge pump, clockwise rotation

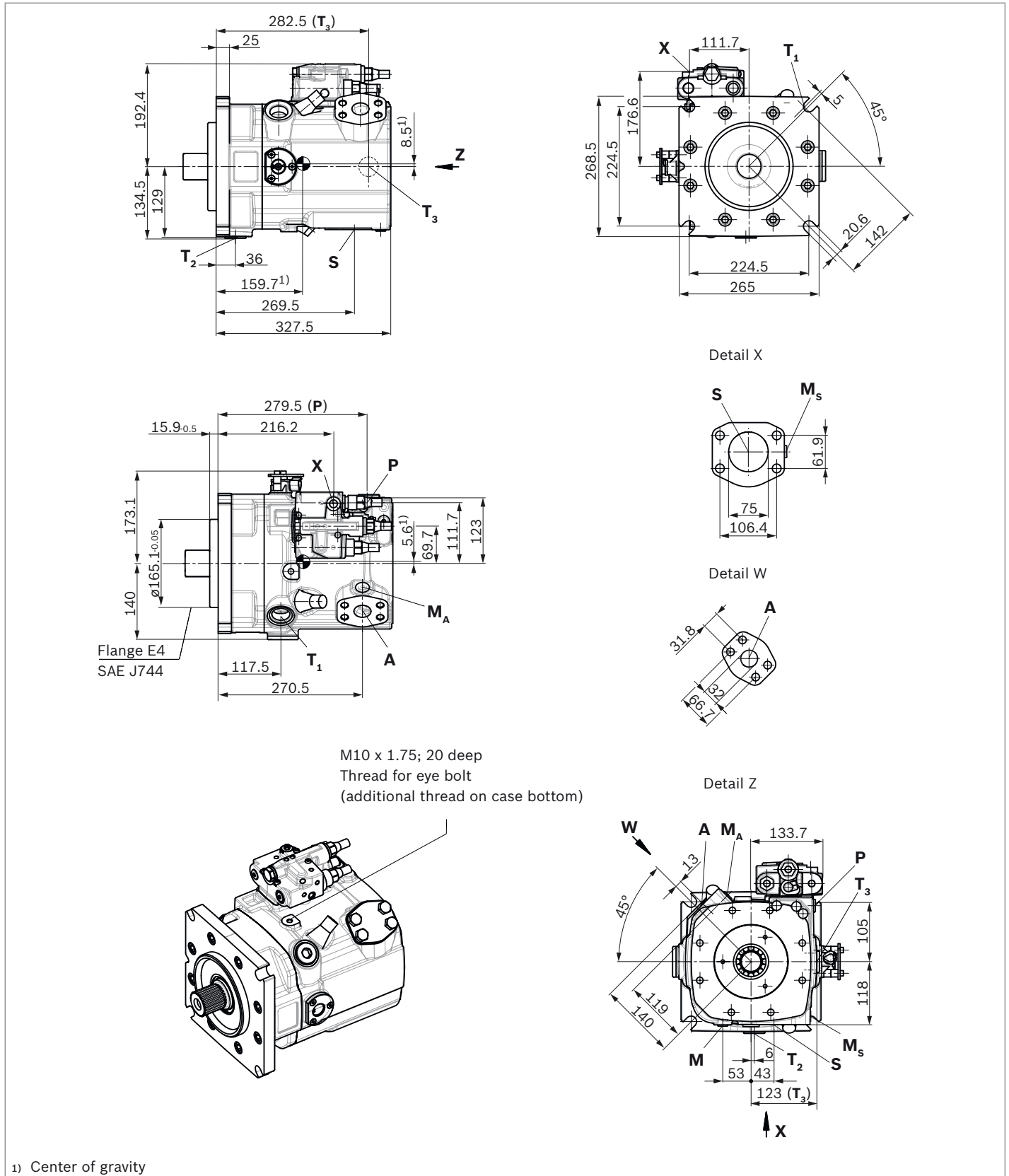

LRDRS0 – Power controller with pressure controller, load-sensing and with electric swivel angle sensor

With charge pump, clockwise rotation

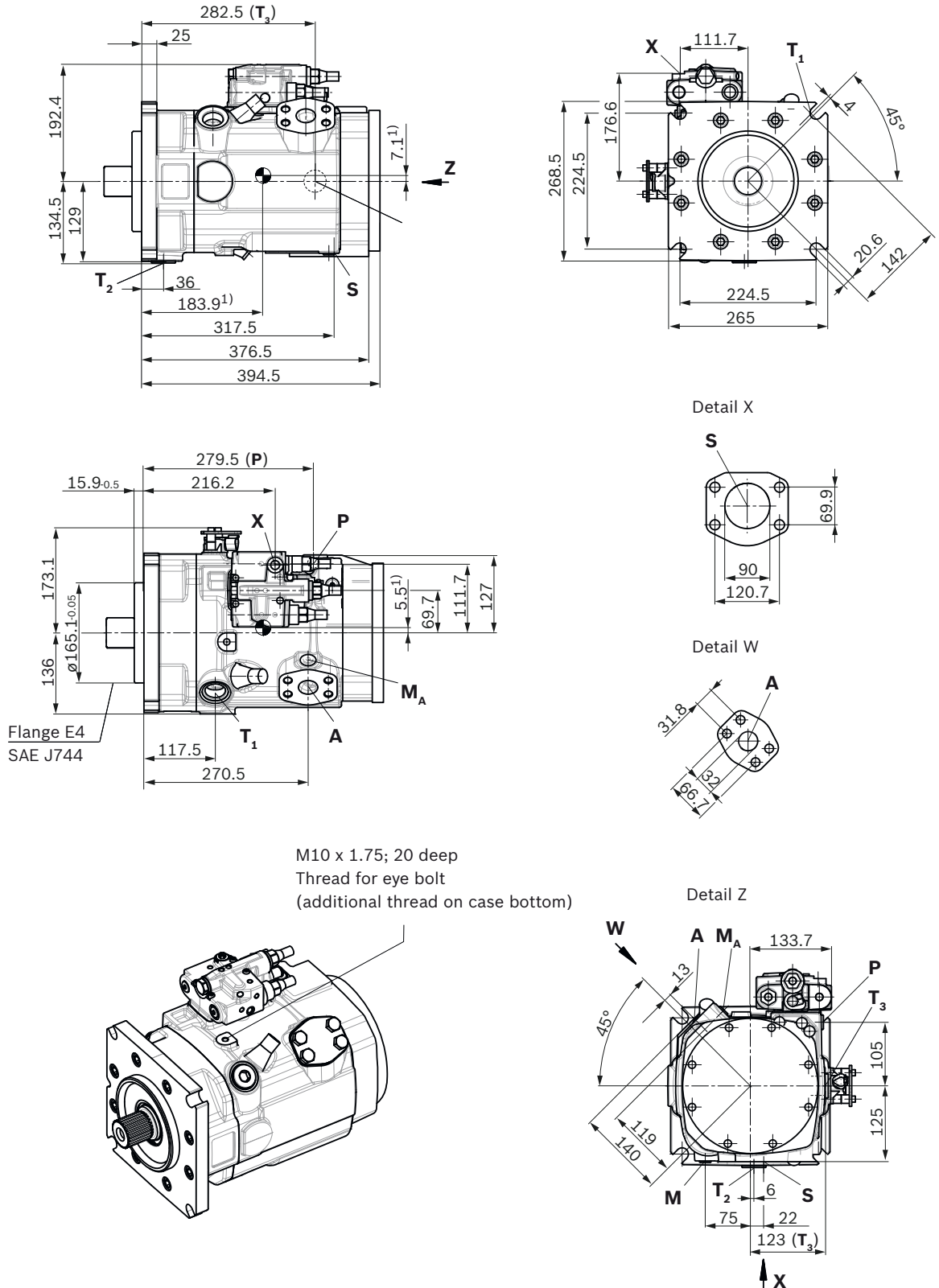

1) Center of gravity

▼ **Splined shaft DIN 5480**

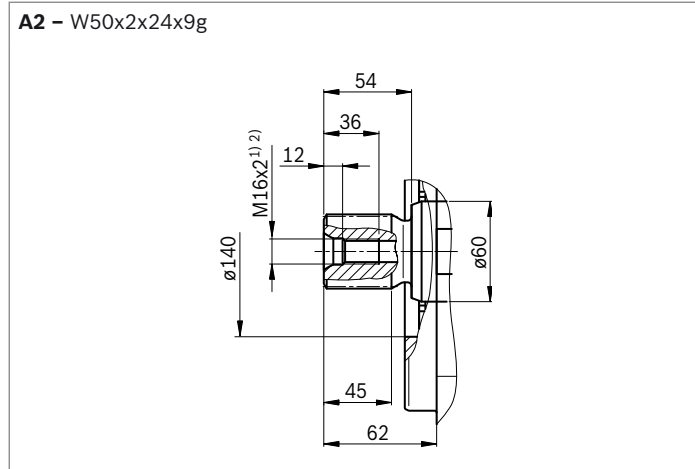

▼ **Parallel keyed shaft DIN 6885**

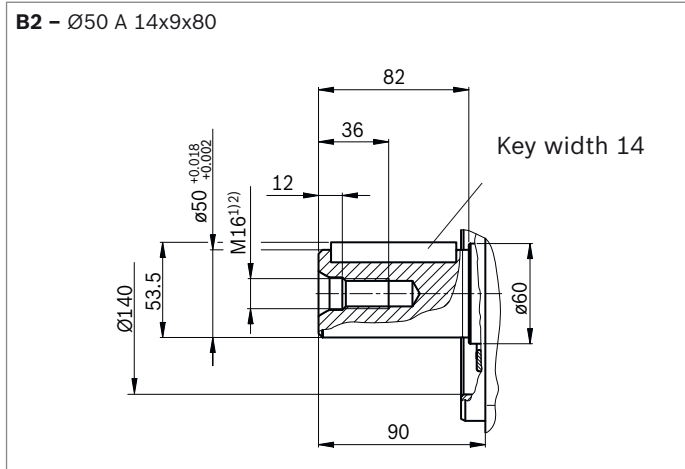

Ports	Standard	Size ²⁾	$p_{\max \text{ abs}}$ [bar] ³⁾	State ⁷⁾	
A	Working port Fastening thread	SAE J518 ⁴⁾ DIN 13	1 1/4 in M14 x 2; 22 deep	420	O
S	Suction port (without charge pump) Fastening thread	SAE J518 ⁴⁾ DIN 13	3 in M16 x 2; 24 deep	30	O
S	Suction port (with charge pump) Fastening thread	SAE J518 ⁴⁾ DIN 13	3 1/2 in M16 x 2; 24 deep	2	O O
T₁	Drain port	ISO 6149 ⁵⁾	M33 x 2; 19 deep	10	O ⁶⁾
T₂	Drain port	ISO 6149 ⁵⁾	M33 x 2; 19 deep	10	X ⁶⁾
T₃	Drain port	ISO 6149 ⁵⁾	M33 x 2; 19 deep	10	X ⁶⁾
CR	Pilot signal (CR only)	ISO 6149	M14 x 1.5; 11.5 deep	420	O
PR	Pilot signal (PR only)	ISO 6149	M14 x 1.5; 11.5 deep	420	O
H3 to H6	Pilot signal (only on H3, H4, H5 and H6)	ISO 6149	M14 x 1.5; 11.5 deep	100	O
X	Pilot signal	ISO 6149 ⁵⁾	M14 x 1.5; 11.5 deep	420	O
DP	Pilot pressure (only on DP)	DIN 3853	S8 form W; 8 deep	420	O
DP₁	Measuring port pilot signal (DP)	ISO 6149	M14 x 1.5; 11.5 deep	420	X
M	Control pressure measuring	ISO 6149 ⁵⁾	M14 x 1.5; 12 deep	420	X
M_A	Measuring pressure A	ISO 6149 ⁵⁾	M14 x 1.5; 12 deep	420	X
M_S	Measuring suction pressure (only A15VSO)	ISO 6149 ⁵⁾	M14 x 1.5; 12 deep	30	X
P	External control pressure (Type code position. 8 version B or C = with external control pressure supply)	ISO 6149 ⁵⁾	M14 x 1.5; 11.5 deep	50	O
	Port P is without function (Type code digit 8 version A = without external control pressure supply)	ISO 6149 ⁵⁾	M18 x 1.5; 14.5 deep	420	X

1) Center bore according to DIN 332 (thread according to DIN 13)
 2) Observe the notes in the instruction manual concerning the maximum tightening torques.
 3) Depending on the application, momentary pressure peaks can occur. Keep this in mind when selecting measuring devices and fittings.
 4) Metric fastening thread is a deviation from standard.

5) The countersink may be deeper than specified in the standard.
 6) Depending on installation position, T₁, T₂ or T₃ must be connected (see also Installation instructions on pages 64 and 65).
 7) O = Must be connected (comes plugged)
 X = Plugged (in normal operation)

▼ **LR - Power controller, fixed setting**

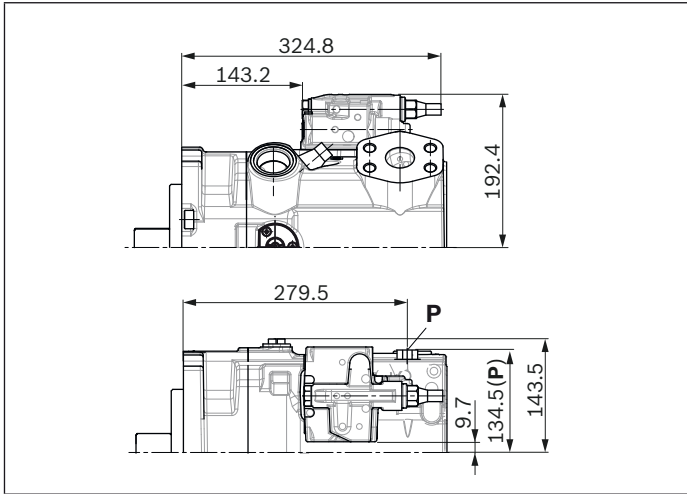

▼ **L4 - Power controller, electric-proportional override**

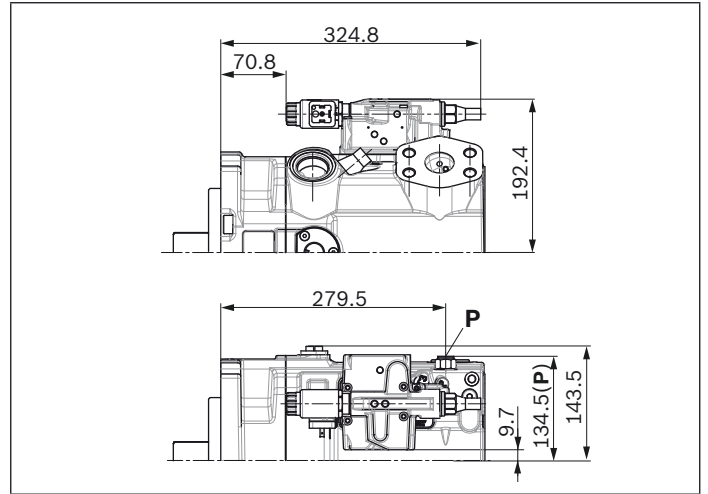

▼ **CR - Power controller, hydraulic-proportional override, high pressure, with stop**

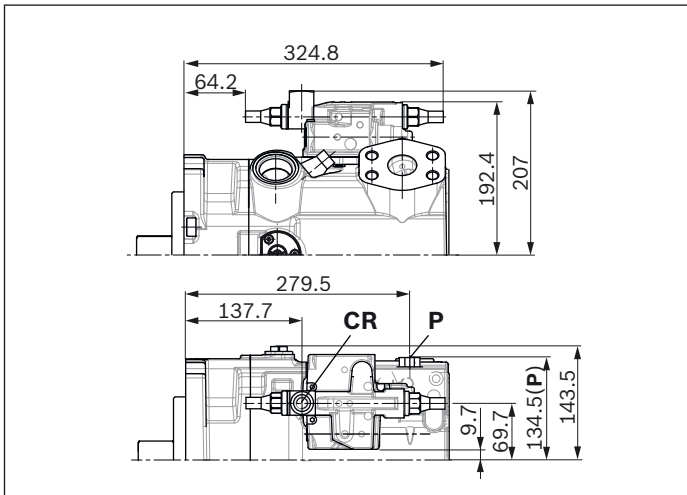

▼ **PR - Power controller, hydraulic-proportional override, high pressure, without stop**

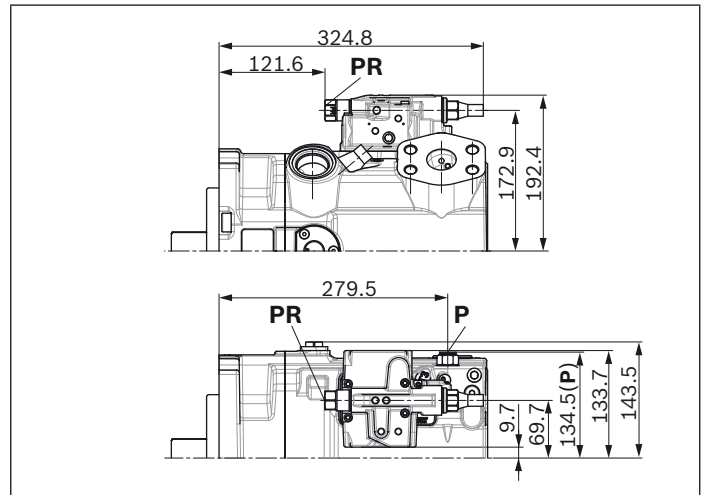

▼ **E2/E6 - Stroke control electric-proportional**

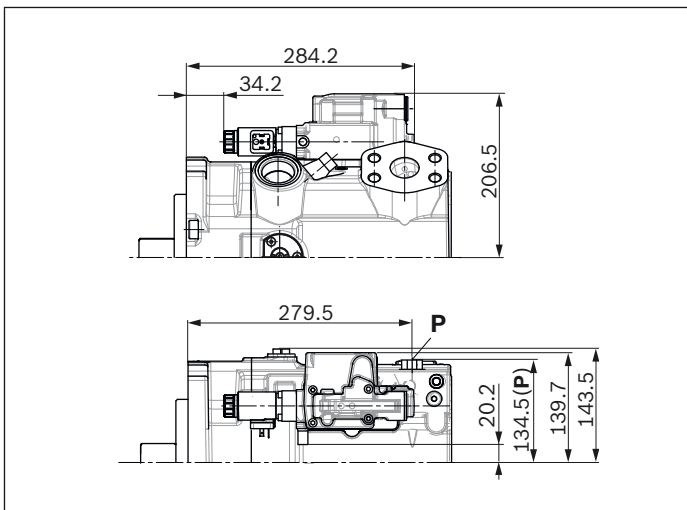

▼ **H3/4/5/6 - Stroke control, hydraulic prop., pilot pressure**

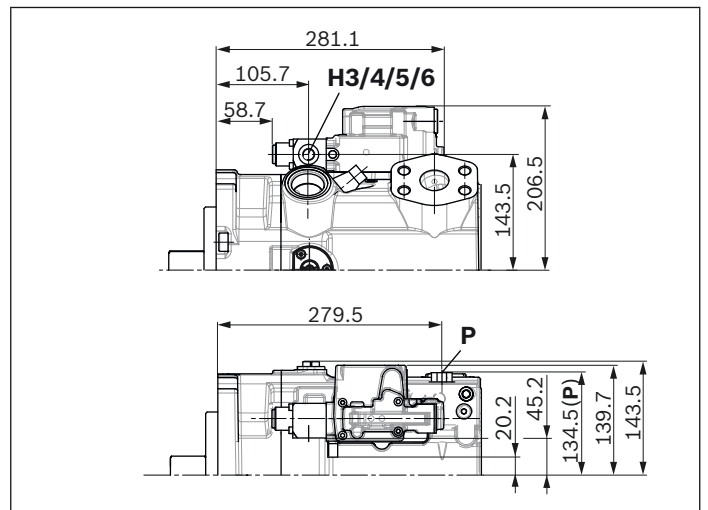

Notice

All controllers described with shuttle valve in **P**
 (some contrary to standard as per type code digit 08)

▼ **DR – Pressure controller, fixed setting**

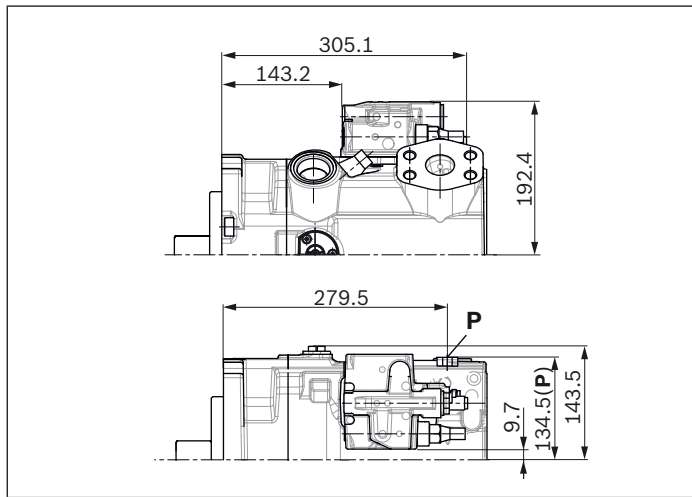

▼ **LRDRS0 – Power controller with pressure controller and load-sensing, fixed setting**

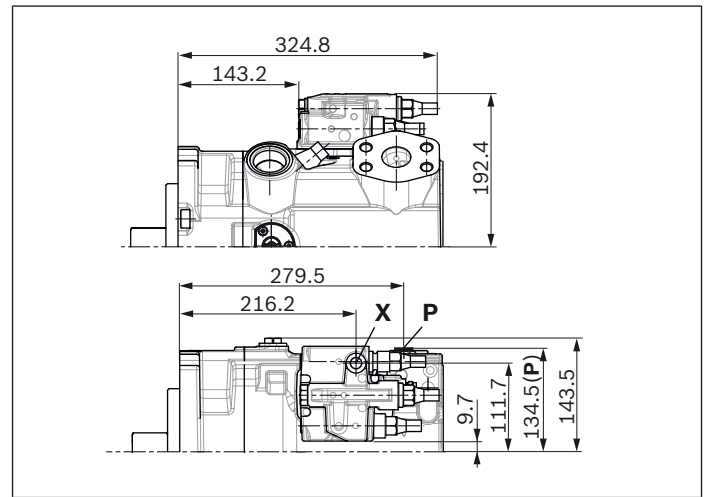

▼ **DG – Pressure controller, hydraulic, remote controlled**

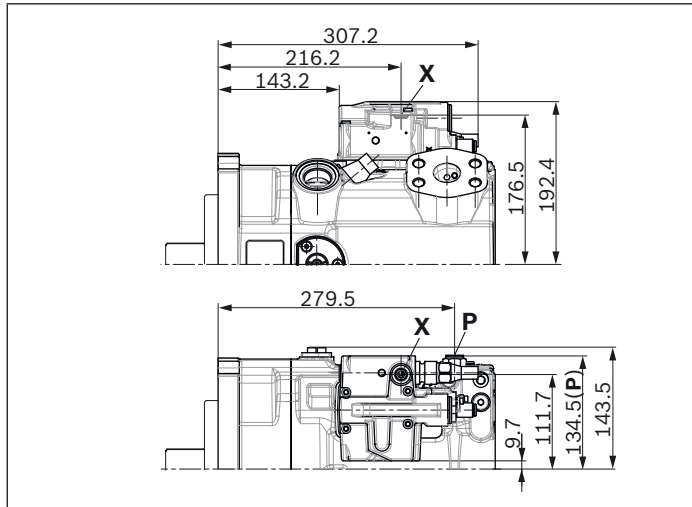

▼ **DP – Pressure controller, for parallel operation**

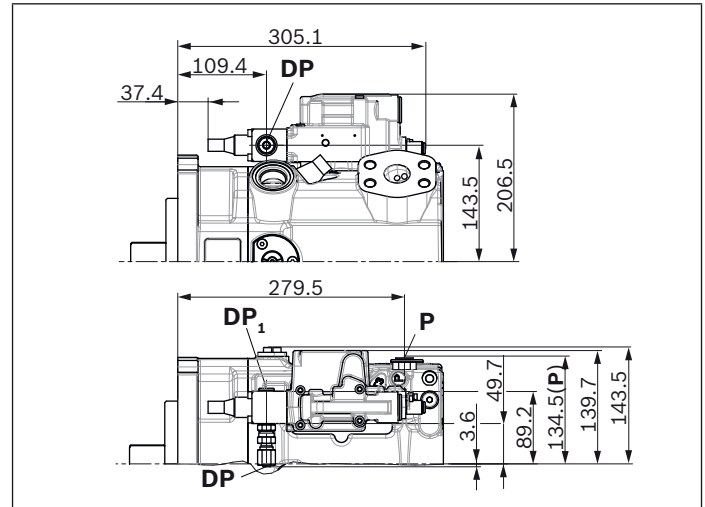

▼ **DGT6/DGT8 – With integrated pilot control valve, electric-proportional override**

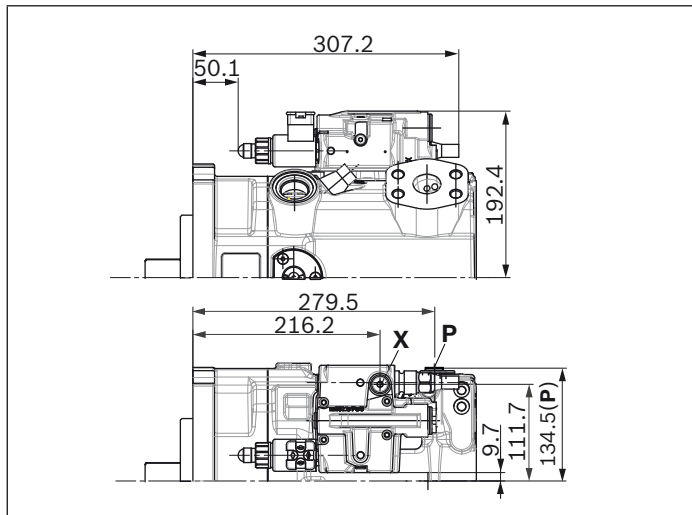

▼ **DGV2 – Electric directional valve and pressure relief valve mounted (only in combination with DG)**

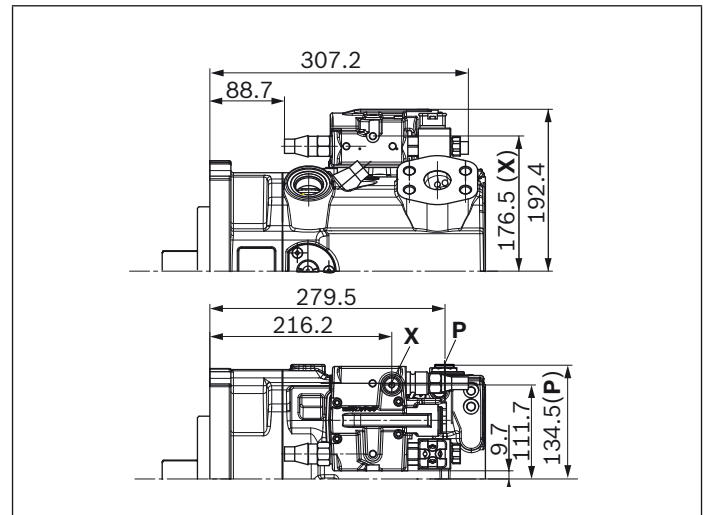

Notice

All controllers described with shuttle valve in **P**
(some contrary to standard as per type code digit 08)

Dimensions, size 210

LRDRS0 - Power controller with pressure controller, load-sensing and with electric swivel angle sensor

Without charge pump, clockwise rotation

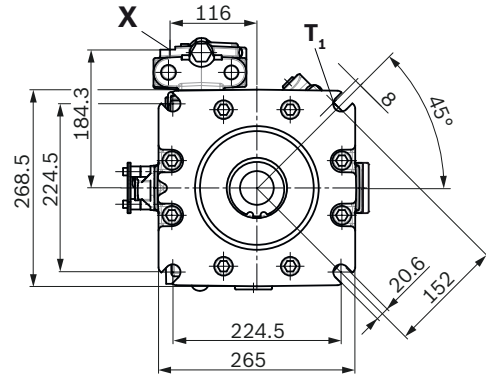
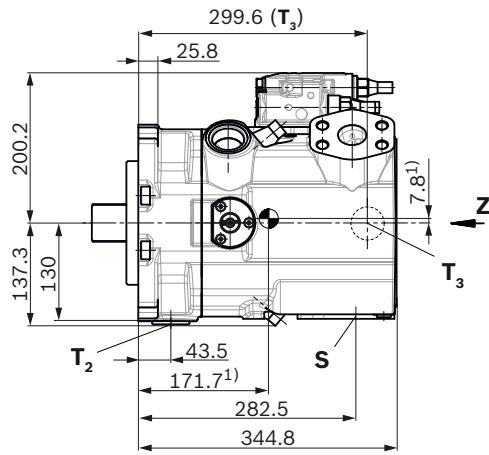

Detail X

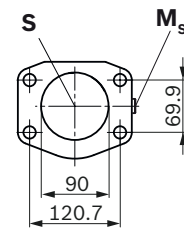

Detail W

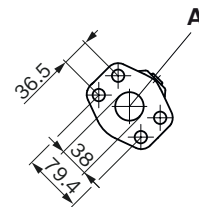

Detail Z

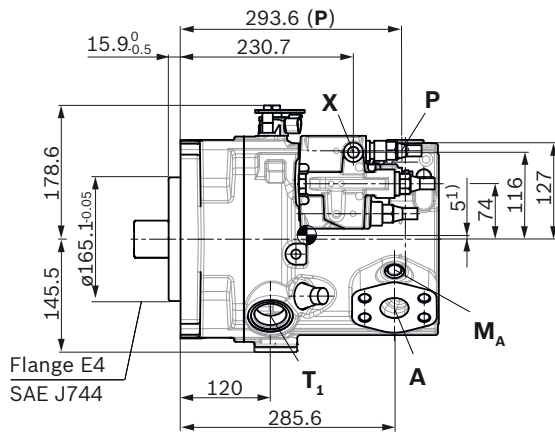
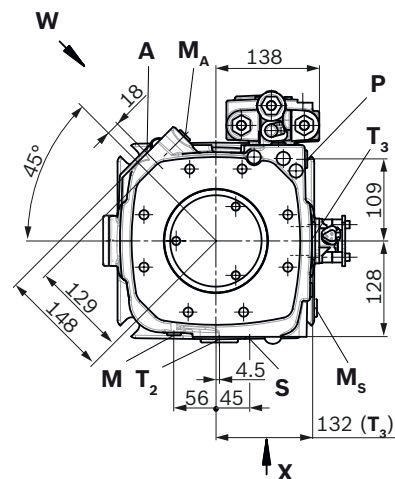

M12 x 1.75; 22 deep
 Thread for eye bolt
 (additional thread on case bottom)

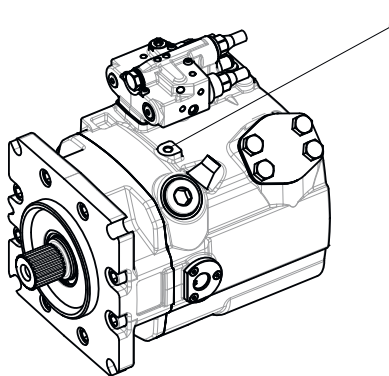

1) Center of gravity

LRDRS0 - Power controller with pressure controller, load-sensing and with electric swivel angle sensor

With charge pump, clockwise rotation

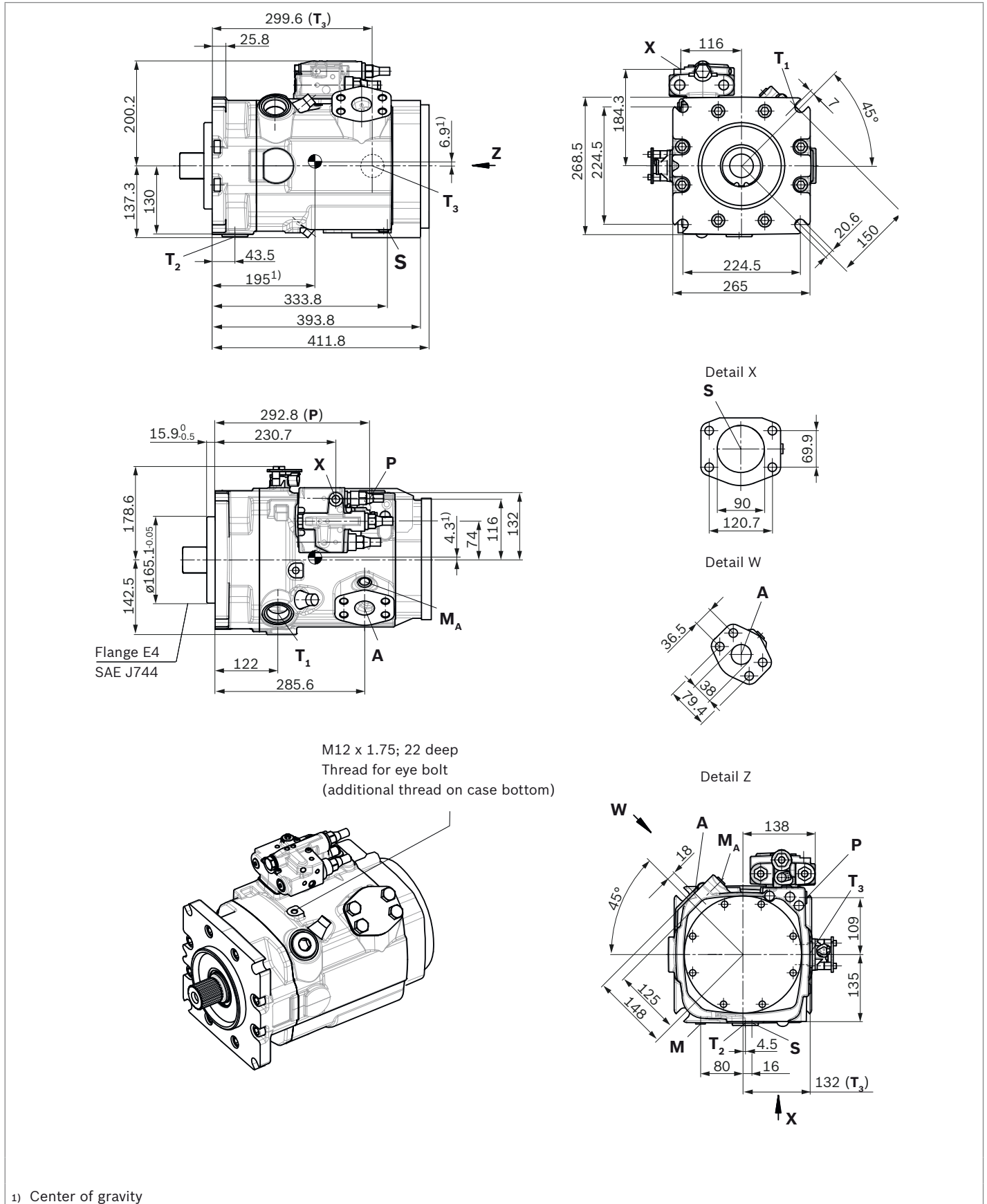

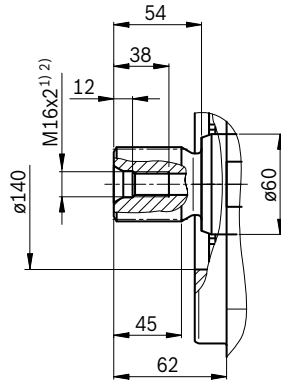
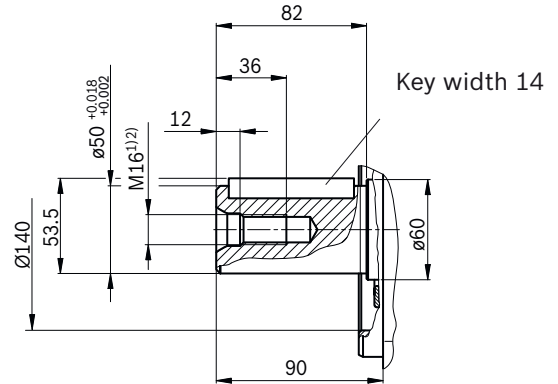
▼ **Splined shaft DIN 5480****A2** – W50x2x24x9g▼ **Parallel keyed shaft DIN 6885****B2** – Ø50 A 14x9x80

Ports	Standard	Size ²⁾	$p_{\max \text{ abs}}$ [bar] ³⁾	State ⁷⁾	
A	Working port Fastening thread	SAE J518 ⁴⁾ DIN 13	1 1/2 in M16 x 2; 24 deep	420	O
S	Suction port (without charge pump) Fastening thread	SAE J518 ⁴⁾ DIN 13	3 1/2 in M16 x 2; 24 deep	30	O
S	Suction port (with charge pump) Fastening thread	SAE J518 ⁴⁾ DIN 13	3 1/2 in M16 x 2; 24 deep	2	O
T₁	Drain port	ISO 6149 ⁵⁾	M42 x 2; 19.5 deep	10	O ⁶⁾
T₂	Drain port	ISO 6149 ⁵⁾	M42 x 2; 19.5 deep	10	X ⁶⁾
T₃	Drain port	ISO 6149 ⁵⁾	M42 x 2; 19.5 deep	10	X ⁶⁾
CR	Pilot signal (CR only)	ISO 6149	M14 x 1.5; 11.5 deep	420	O
PR	Pilot signal (PR only)	ISO 6149	M14 x 1.5; 11.5 deep	420	O
H3 to H6	Pilot signal (only on H3, H4, H5 and H6)	ISO 6149	M14 x 1.5; 11.5 deep	100	O
X	Pilot signal	ISO 6149 ⁵⁾	M14 x 1.5; 11.5 deep	420	O
DP	Pilot pressure (only on DP)	DIN 3853	S8 form W; 8 deep	420	O
DP₁	Measuring port pilot signal (DP)	ISO 6149	M14 x 1.5; 11.5 deep	420	X
M	Control pressure measuring	ISO 6149 ⁵⁾	M14 x 1.5; 12 deep	420	X
M_A	Measuring pressure A	ISO 6149 ⁵⁾	M14 x 1.5; 12 deep	420	X
M_S	Measuring suction pressure (only A15VSO)	ISO 6149 ⁵⁾	M14 x 1.5; 12 deep	30	X
P	External control pressure (Type code digit 8 version B or C = with external control pressure supply)	ISO 6149 ⁵⁾	M14 x 1.5; 11.5 deep	50	O
	Port P is without function (Type code digit 8 version A = without external control pressure supply)	ISO 6149 ⁵⁾	M18 x 1.5; 14.5 deep	420	X

1) Center bore according to DIN 332 (thread according to DIN 13)

2) Observe the notes in the instruction manual concerning the maximum tightening torques.

3) Depending on the application, momentary pressure peaks can occur. Keep this in mind when selecting measuring devices and fittings.

4) Metric fastening thread is a deviation from standard.

5) The countersink may be deeper than specified in the standard.

6) Depending on installation position, T₁, T₂ or T₃ must be connected (see also Installation instructions on pages 64 and 65).

7) O = Must be connected (comes plugged)

X = Plugged (in normal operation)

▼ **LR – Power controller, fixed setting**

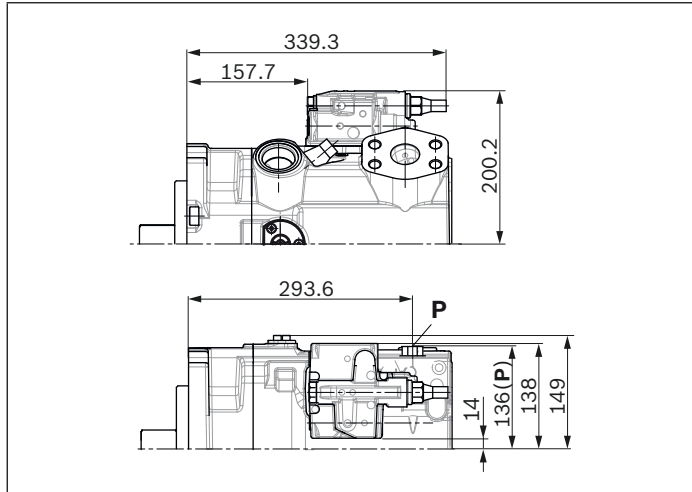

▼ **L4 – Power controller, electric-proportional override**

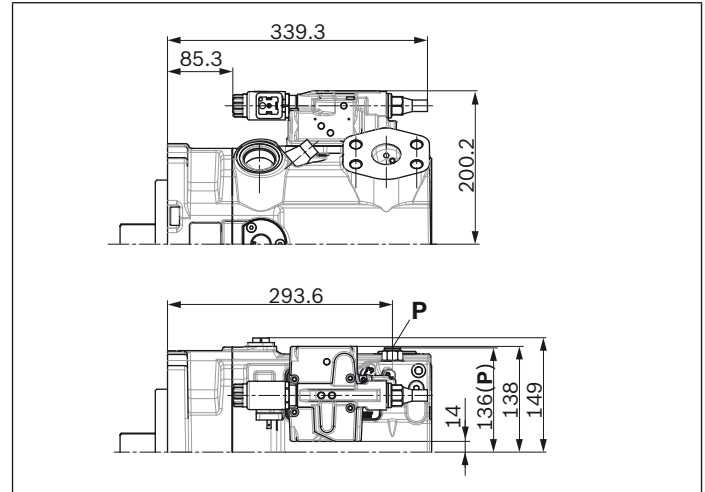

▼ **CR – Power controller, hydraulic-proportional override, high pressure, with stop**

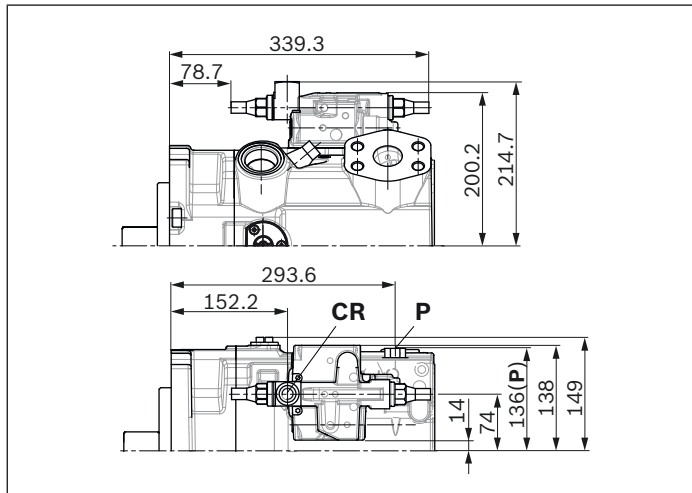

▼ **PR – Power controller, hydraulic-proportional override, high pressure, without stop**

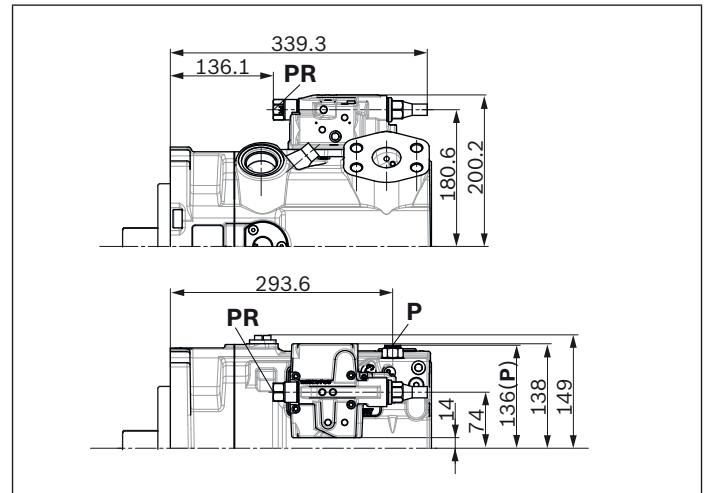

▼ **E2/E6 – Stroke control electric-proportional**

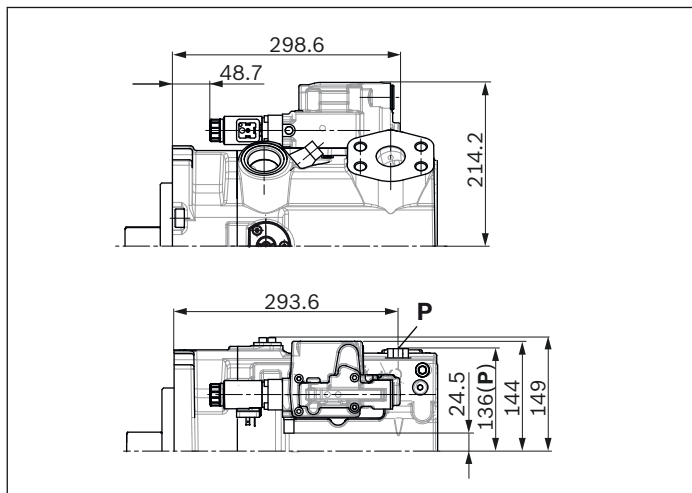

▼ **H3/4/5/6 – Stroke control, hydraulic prop., pilot pressure**

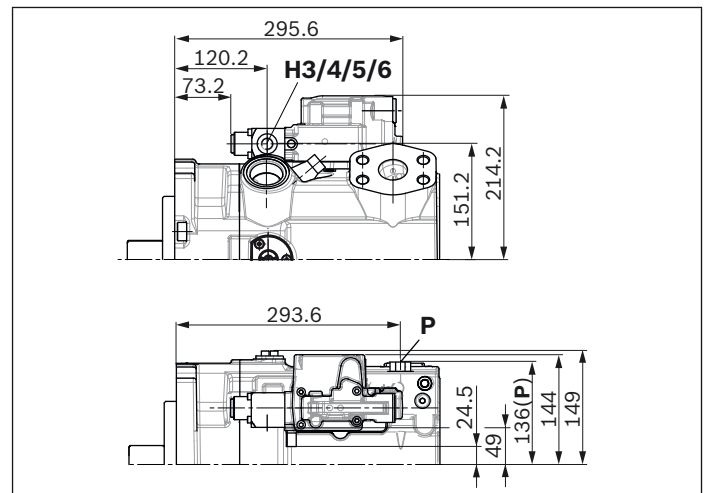

Notice

All controllers described with shuttle valve in **P**
 (some contrary to standard as per type code digit 08)

▼ **DR – Pressure controller, fixed setting**

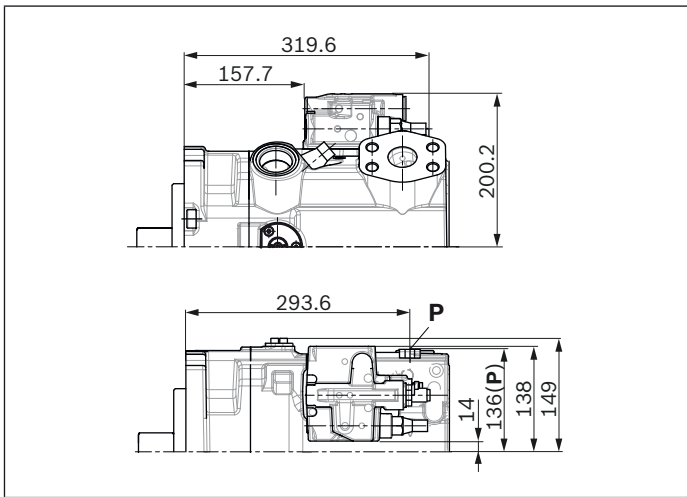

▼ **LRDRS0 – Power controller with pressure controller and load-sensing, fixed setting**

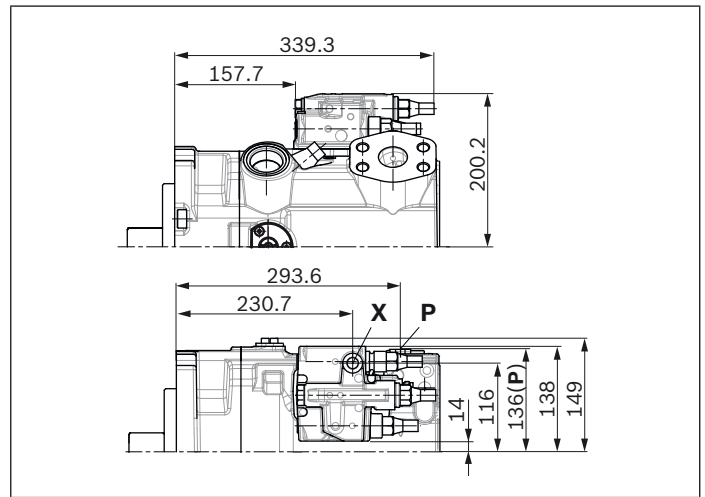

▼ **DG – Pressure controller, hydraulic, remote controlled**

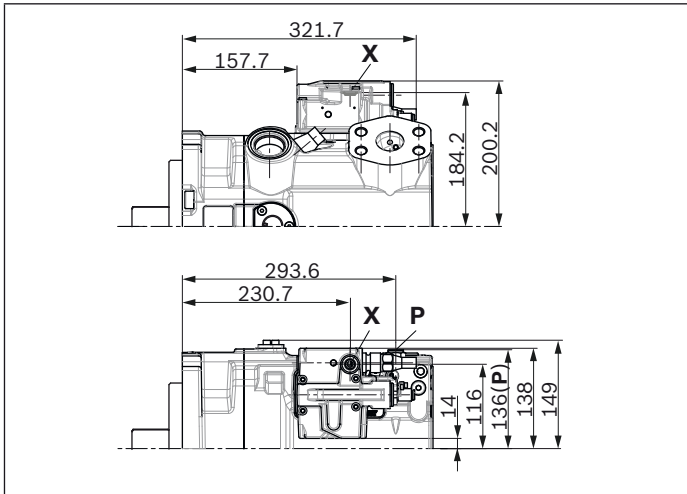

▼ **DP – Pressure controller, for parallel operation**

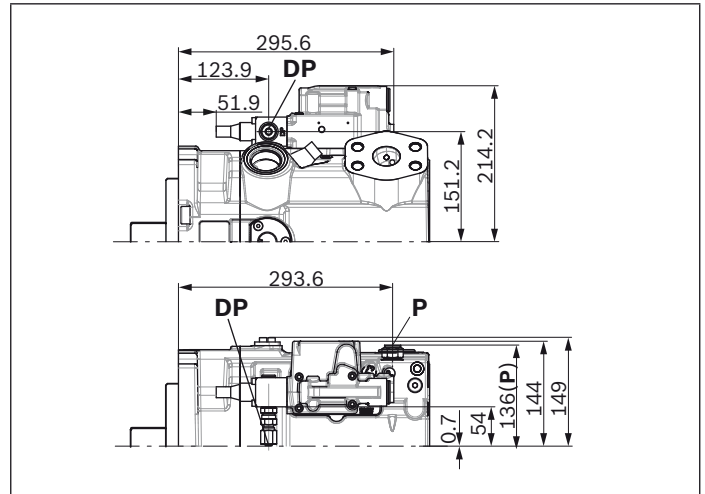

▼ **DGT6/DGT8 – With integrated pilot control valve, electric-proportional override**

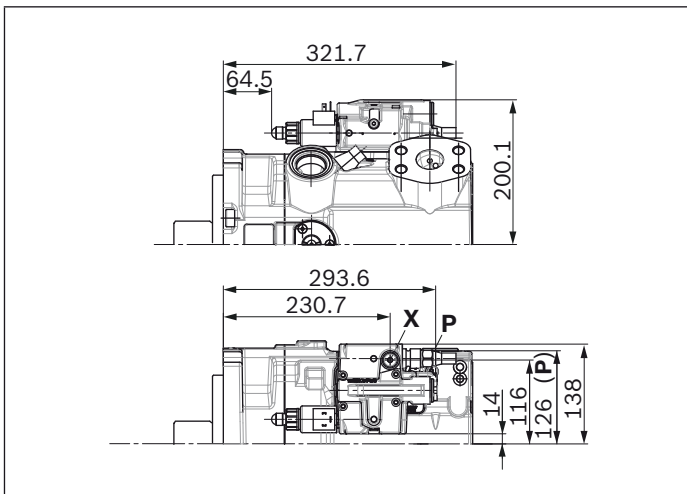

▼ **DGV2 – Electric directional valve and pressure relief valve mounted (only in combination with DG)**

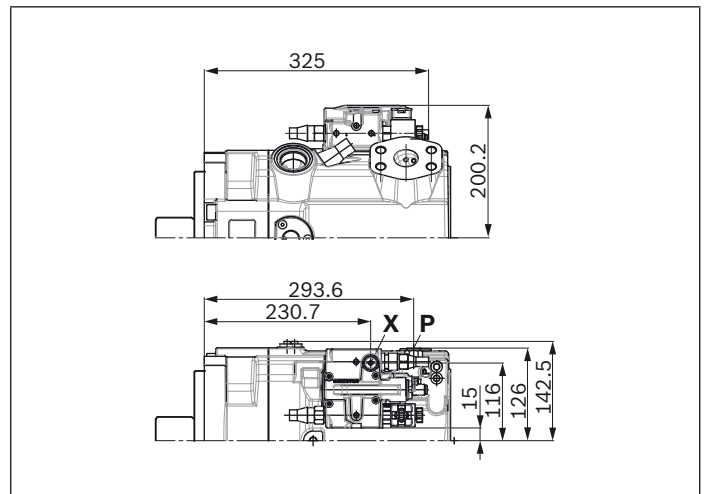

Notice

All controllers described with shuttle valve in **P**
 (some contrary to standard as per type code digit 08)

Dimensions, size 280

LRDRS0 – Power controller with pressure controller, load-sensing and with electric swivel angle sensor

Without charge pump, clockwise rotation

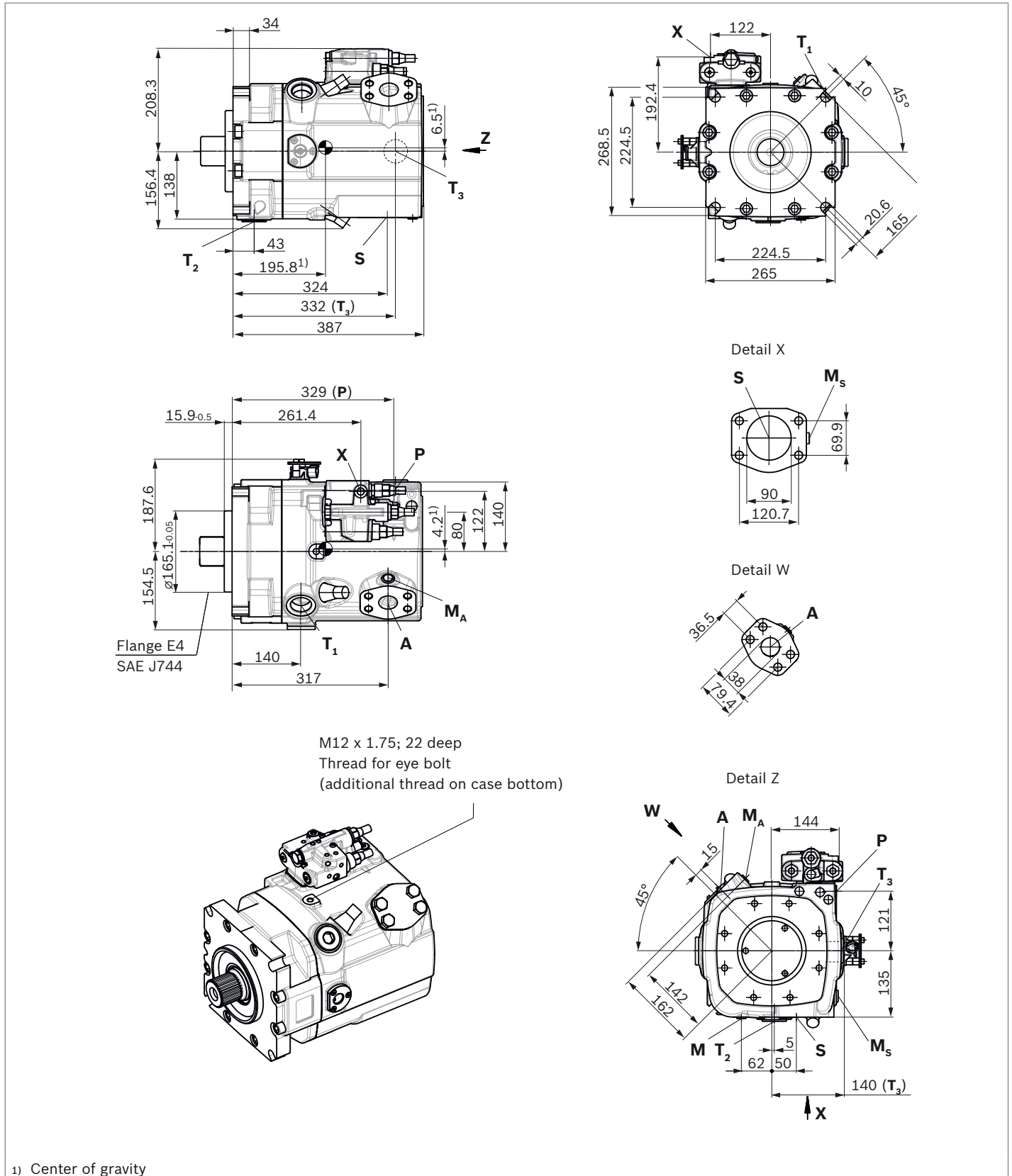

LRDRS0 – Power controller with pressure controller, load-sensing and with electric swivel angle sensor

With charge pump, clockwise rotation

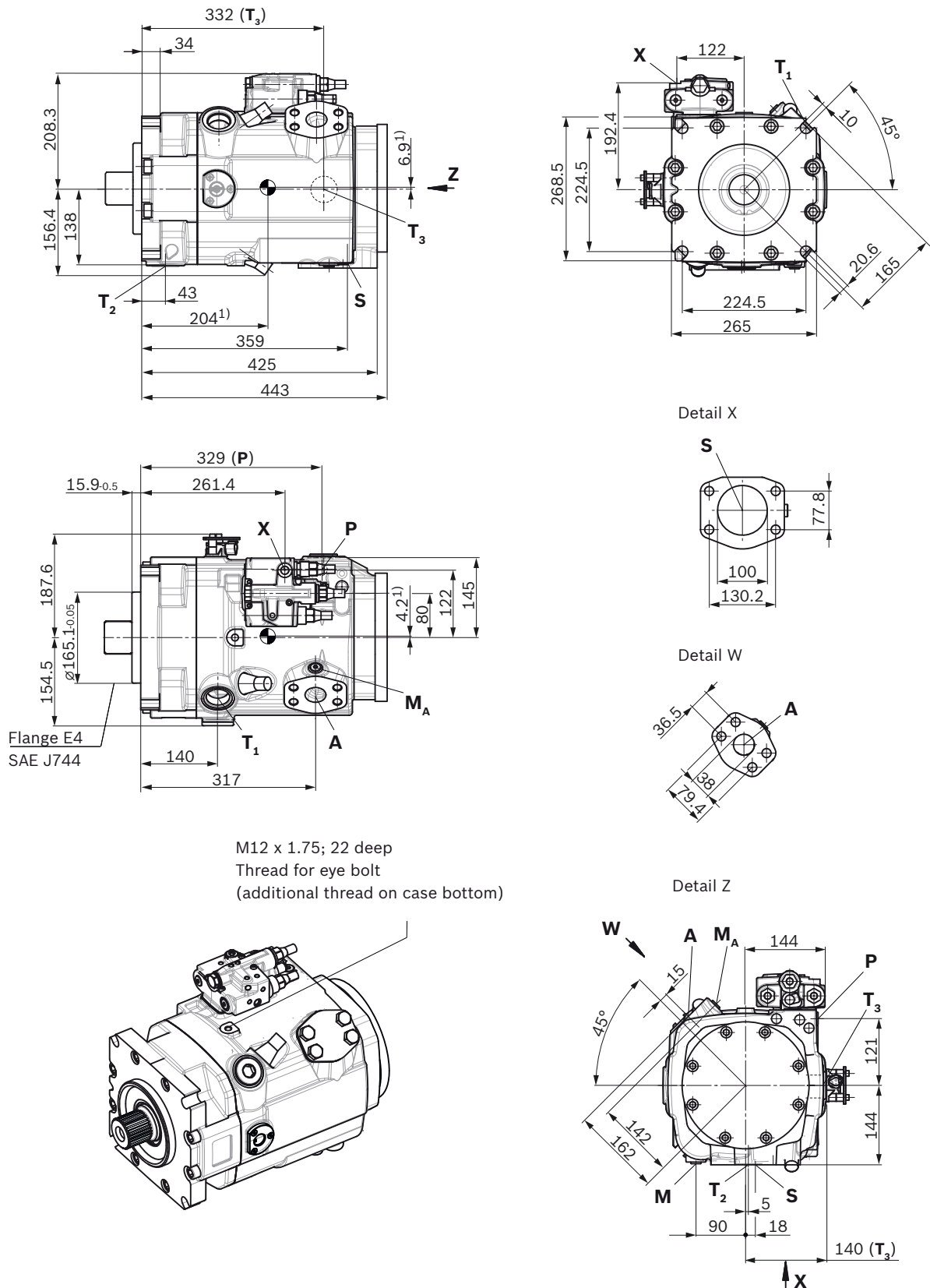

1) Center of gravity

▼ **Splined shaft DIN 5480**

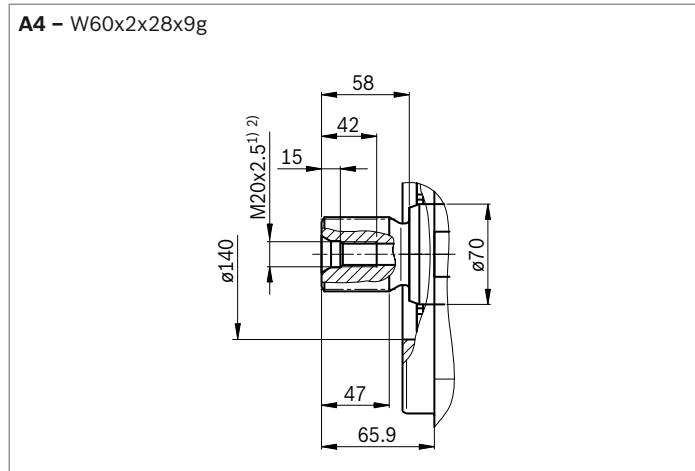

▼ **Parallel keyed shaft DIN 6885**

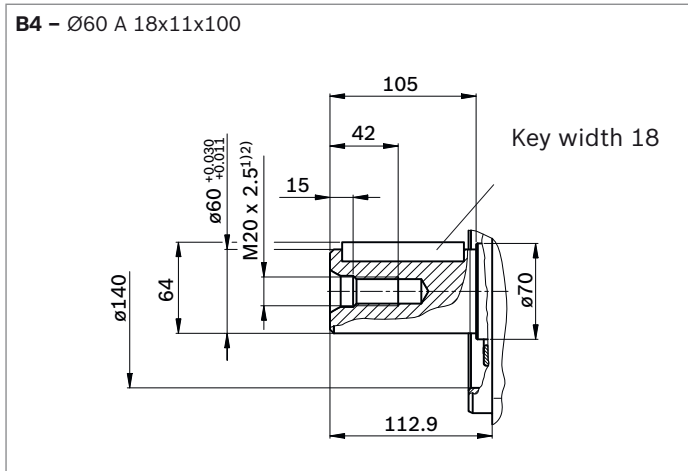

Ports	Standard	Size ²⁾	$p_{\max \text{ abs}}$ [bar] ³⁾	State ⁷⁾
A	Working port Fastening thread	SAE J518 ⁴⁾ DIN 13	1 1/2 in M16 x 2; 24 deep	420 O
S	Suction port (without charge pump) Fastening thread	SAE J518 ⁴⁾ DIN 13	3 1/2 in M16 x 2; 24 deep	30 O
S	Suction port (with charge pump) Fastening thread	SAE J518 ⁴⁾ DIN 13	4 in M16 x 2; 24 deep	2 O
T₁	Drain port	ISO 6149 ⁵⁾	M42 x 2; 19.5 deep	10 O ⁶⁾
T₂	Drain port	ISO 6149 ⁵⁾	M42 x 2; 19.5 deep	10 X ⁶⁾
T₃	Drain port	ISO 6149 ⁵⁾	M42 x 2; 19.5 deep	10 X ⁶⁾
CR	Pilot signal (CR only)	ISO 6149	M14 x 1.5; 11.5 deep	420 O
PR	Pilot signal (PR only)	ISO 6149	M14 x 1.5; 11.5 deep	420 O
H3 to H6	Pilot signal (only on H3, H4, H5 and H6)	ISO 6149	M14 x 1.5; 11.5 deep	100 O
X	Pilot signal	ISO 6149 ⁵⁾	M14 x 1.5; 11.5 deep	420 O
DP	Pilot pressure (only on DP)	DIN 3853	S8 form W; 8 deep	420 O
DP₁	Measuring port pilot signal (DP)	ISO 6149	M14 x 1.5; 11.5 deep	420 X
M	Control pressure measuring	ISO 6149 ⁵⁾	M14 x 1.5; 12 deep	420 X
M_A	Measuring pressure A	ISO 6149 ⁵⁾	M14 x 1.5; 12 deep	420 X
M_S	Measuring suction pressure (only A15VSO)	ISO 6149 ⁵⁾	M14 x 1.5; 12 deep	30 X
P	External control pressure (Type code digit 8 version B or C = with external control pressure supply)	ISO 6149 ⁵⁾	M14 x 1.5; 11.5 deep	50 O
	Port P is without function (Type code digit 8 version A = without external control pressure supply)	ISO 6149 ⁷⁾	M18 x 1.5; 14.5 deep	420 X

- 1) Center bore according to DIN 332 (thread according to DIN 13)
- 2) Observe the notes in the instruction manual concerning the maximum tightening torques.
- 3) Depending on the application, momentary pressure peaks can occur. Keep this in mind when selecting measuring devices and fittings.
- 4) Metric fastening thread is a deviation from standard.

- 5) The countersink may be deeper than specified in the standard.
- 6) Depending on installation position, T₁, T₂ or T₃ must be connected (see also Installation instructions on pages 64 and 65).
- 7) O = Must be connected (comes plugged)
X = Plugged (in normal operation)

▼ **LR - Power controller, fixed setting**

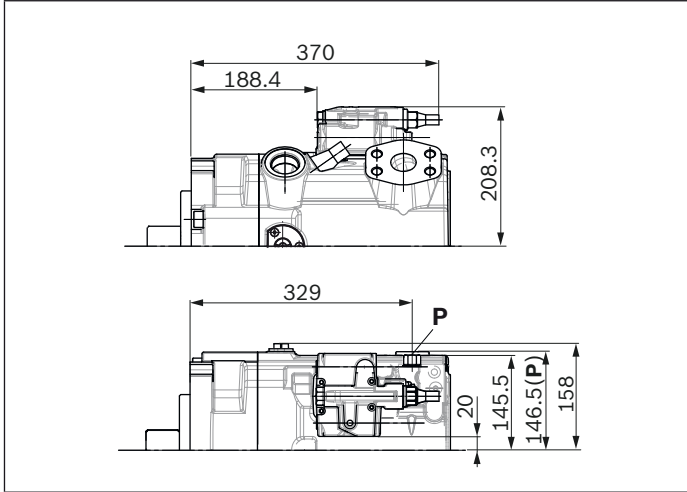

▼ **L4 - Power controller, electric-proportional override**

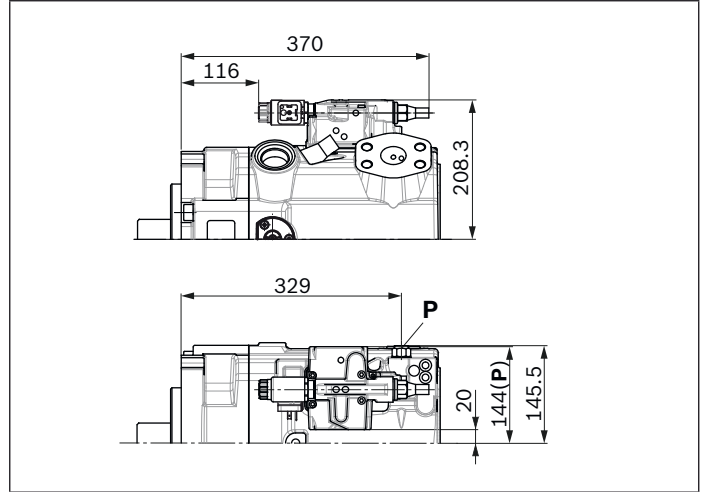

▼ **CR - Power controller, hydraulic-proportional override, high pressure, with stop**

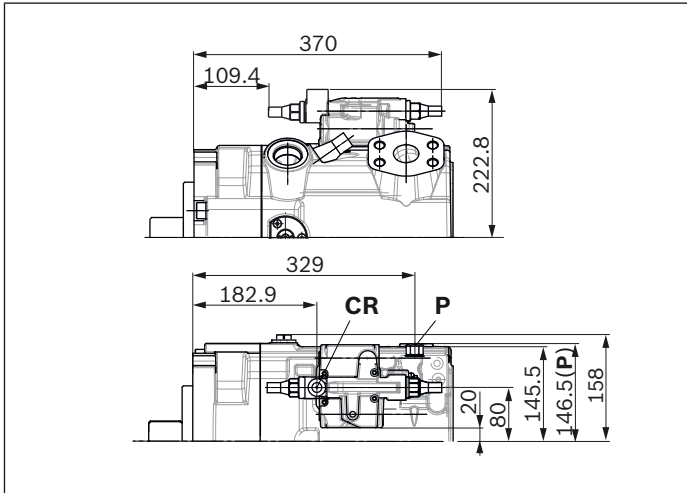

▼ **PR - Power controller, hydraulic-proportional override, high pressure, without stop**

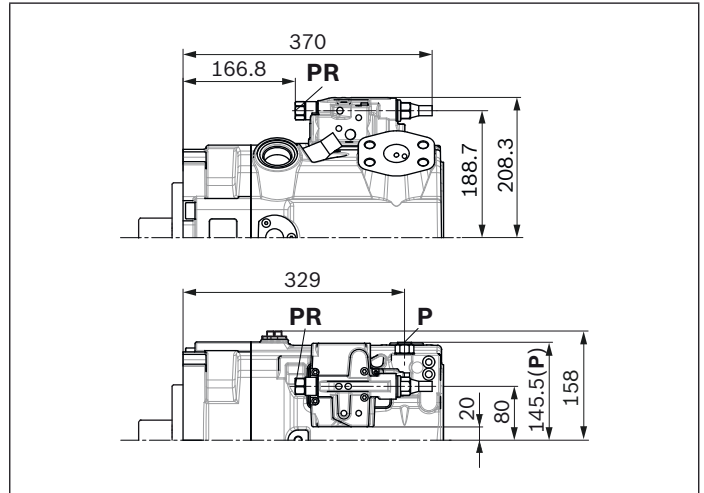

▼ **E2/E6 - Stroke control electric-proportional**

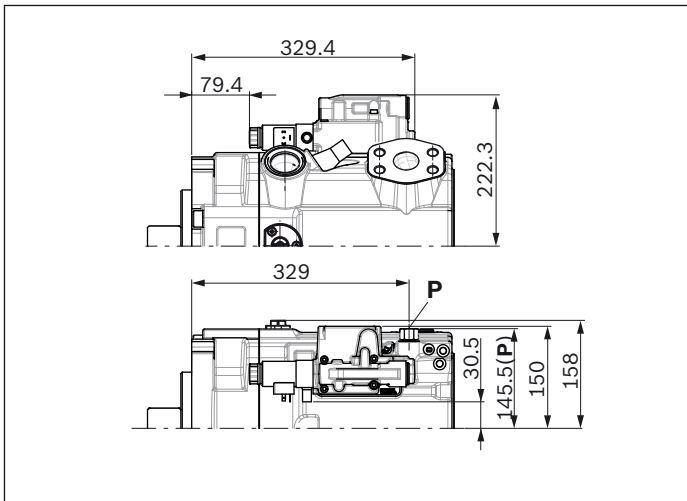

▼ **H3/4/5/6 - Stroke control, hydraulic prop., pilot pressure**

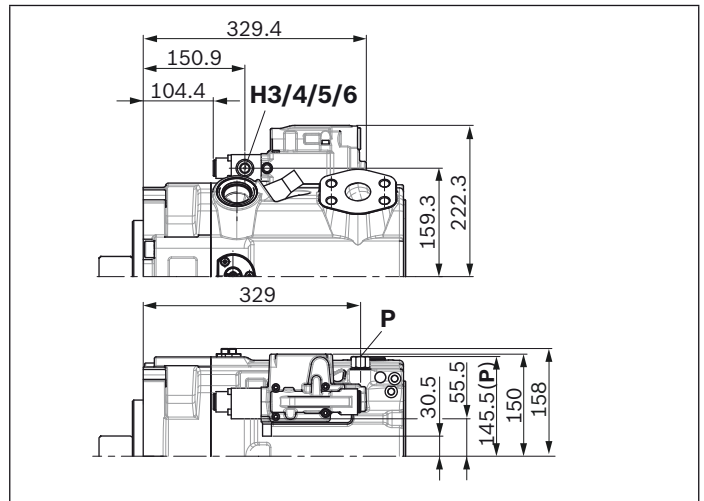

Notice

All controllers described with shuttle valve in **P**
 (some contrary to standard as per type code digit 08)

▼ **DR – Pressure controller, fixed setting**

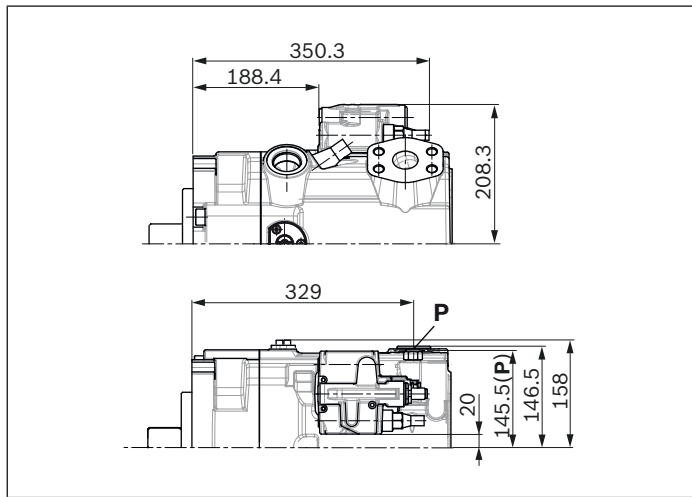

▼ **LRDRS0 – Power controller with pressure controller and load-sensing, fixed setting**

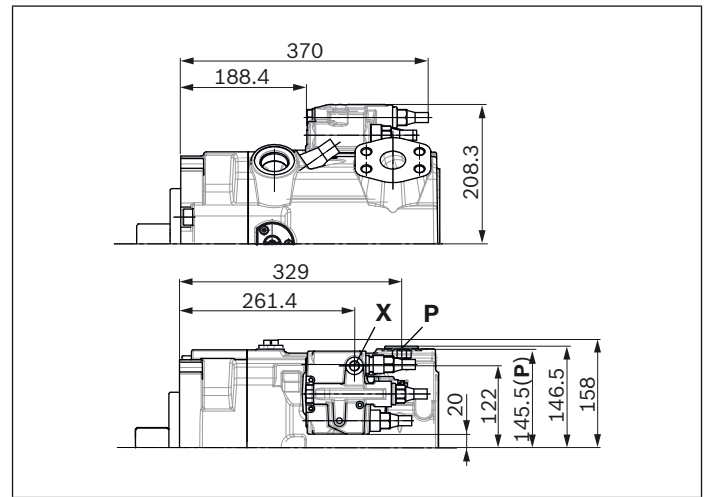

▼ **DG – Pressure controller, hydraulic, remote controlled**

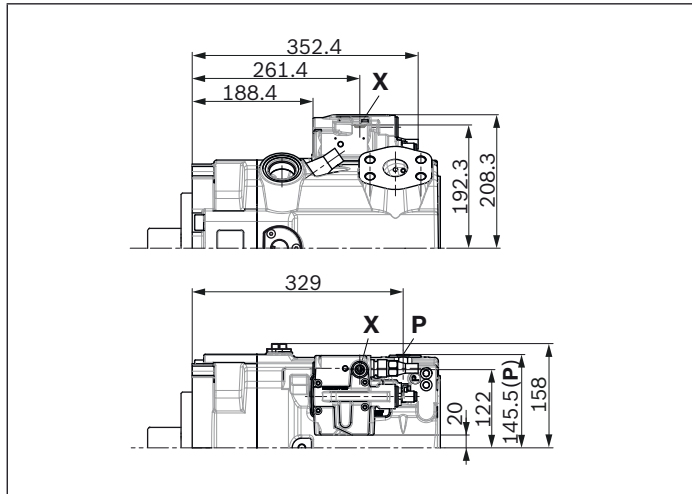

▼ **DP – Pressure controller, for parallel operation**

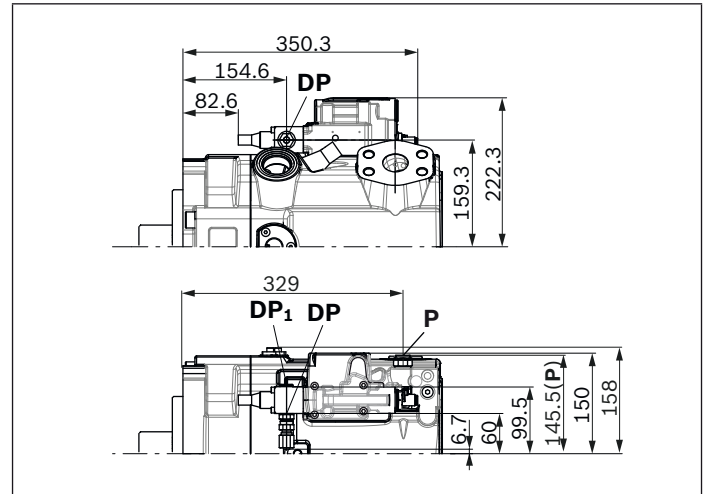

▼ **DGT6/DGT8 – With integrated pilot control valve, electric-proportional override**

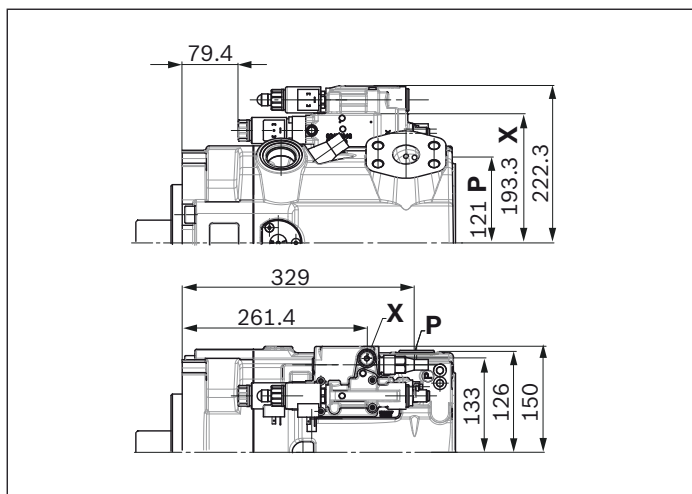

▼ **DGV2 – Electric directional valve and pressure relief valve mounted (only in combination with DG)**

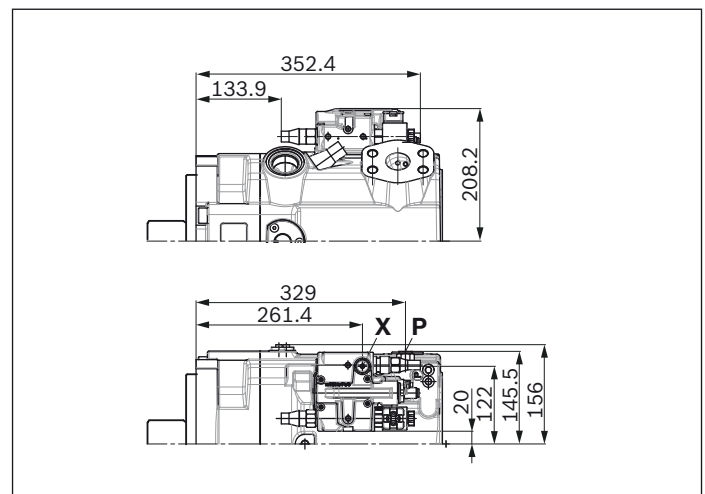

Notice

All controllers described with shuttle valve in **P**
 (some contrary to standard as per type code digit 08)

Dimensions, through drive

Flange SAE J744			Hub for splined shaft ²⁾			Availability across sizes					Code
Diameter	Attachment ¹⁾	Designation	Diameter		Designation	110	145	175	210	280	
82-2 (A)	⊗	A3	5/8 in	9T 16/32DP	S2	●	●	●	●	●	A3S2
101-2 (B)	⊗	B3	7/8 in	13T 16/32DP	S4	●	●	●	●	●	B3S4
			1 in	15T 16/32DP	S5	●	●	●	●	●	B3S5

● = Available ○ = On request

▼ 82-2 (A)

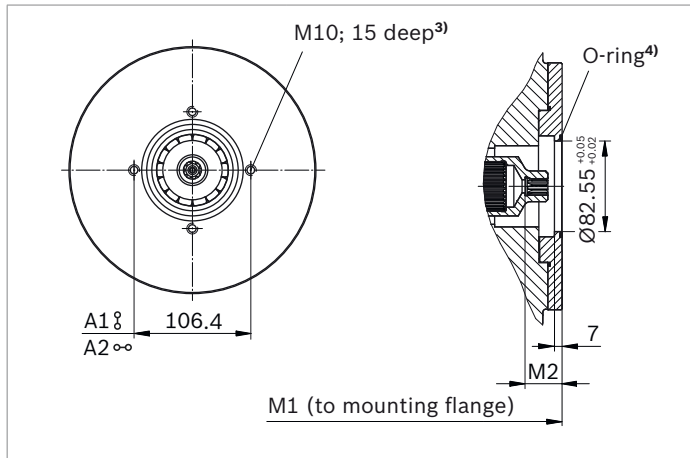

A3S2	NG	M1	M2
without charge pump	110	301	34
	145	326	40
	175	340.5	33.8
	210	357.8	33.8
	280	400	33.8
with charge pump	145	375	40
	175	389.5	33.8
	210	406.8	33.8
	280	438	33.8

▼ 101-2 (B)

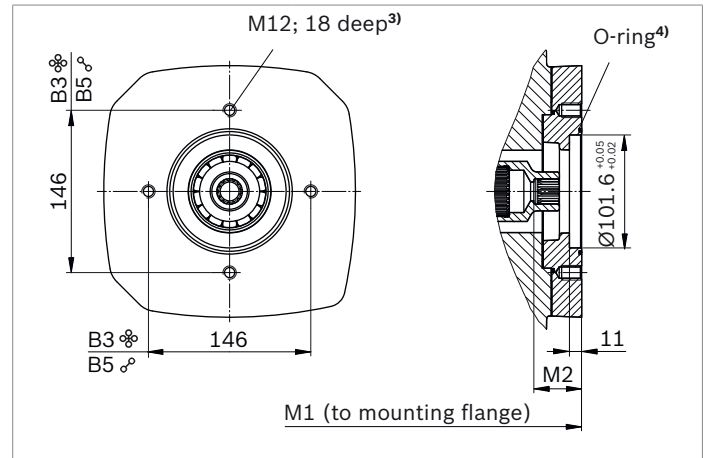

B3S4, B3S5	NG	M1	M2
without charge pump	110	312	43
	145	337	43
	175	354.5	43
	210	371.8	43
	280	414	43
with charge pump	145	386	43
	175	403.5	43
	210	420.8	43
	280	452	43

1) Mounting holes pattern viewed on through drive with control at top.
 2) According to ANSI B92.1a, 30° pressure angle, flat root, side fit, tolerance class 5

3) Thread according to DIN 13; observe the max. tightening torques in the instruction manual.
 4) O-ring included in the scope of delivery

Flange SAE J744			Splined shaft			Availability across sizes					Code
Diameter	Attachment ¹⁾	Designation	Diameter		Designation	110	145	175	210	280	
127-2 (C)	☼	C3	1 1/4 in	14T 12/24DP ²⁾	S7	●	●	●	●	●	C3S7
			1 1/2 in	17T 12/24DP ²⁾	S9	●	●	●	●	●	C3S9
152-4 (D)	☼	D4	W45x2x21x9g ³⁾		A1	●	●	●	●	●	D4A1
			W50x2x24x9g ³⁾		A2	-	●	●	●	●	D4A2

● = Available ○ = On request

▼ **127-2 (C)**

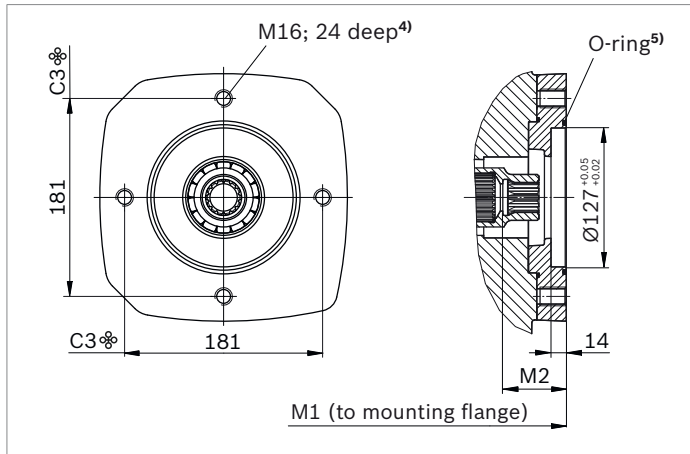

▼ **152-4 (D)**

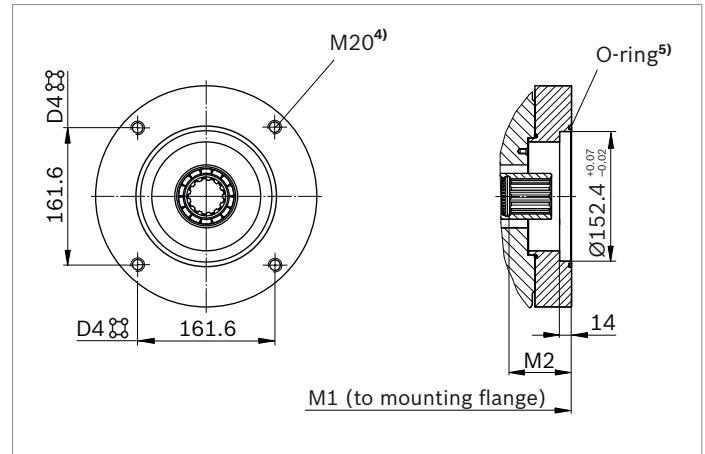

C3S7	NG	M1	M2
without charge pump	110	323	58
	145	348	58
	175	354.5	58.1
	210	371.8	58.1
	280	414	58.1
with charge pump	145	396.7	58
	175	403.5	58.1
	210	420.8	58.1
	280	452	58.1
C3S9	NG	M1	M2
without charge pump	110	323	64
	175	359.5	64
	210	376.8	64
	280	414	64
with charge pump	145	414	64
	175	409	64
	210	425.8	64
	280	452	64

D4A1	NG	M1	M2
without charge pump	110	325	62
	145	350	62
	175	364	60
	210	381	60
	280	414	65.1
	with charge pump	145	399
with charge pump	175	413	60
	210	430	60
	280	452	65.1
	D4A2	NG	M1
without charge pump	145	350	66
	175	364	68
	210	381	68
	280	423	65
with charge pump	145	399	66
	175	413	68
	210	430	68
	280	461	65

1) Mounting holes pattern viewed on through drive with control at top.
2) Hub for splined shaft according to ANSI B92.1a, 30° pressure angle, flat root, side fit, tolerance class 5

3) Hub for splined shaft according to DIN 5480
4) Thread according to DIN 13; observe the max. tightening torques in the instruction manual.
5) O-ring included in the scope of delivery

Flange SAE J744			Splined shaft		Availability across sizes					Code
Diameter	Attachment ¹⁾	Designation	Diameter	Designation	110	145	175	210	280	
165-4 (E)		E4	W50x2x24x9g ³⁾	A2	-	-	●	●	●	E4A2
			W60x2x28x9g ³⁾	A4	-	-	-	-	●	E4A4

● = Available ○ = On request

▼ **165-4 (E)**

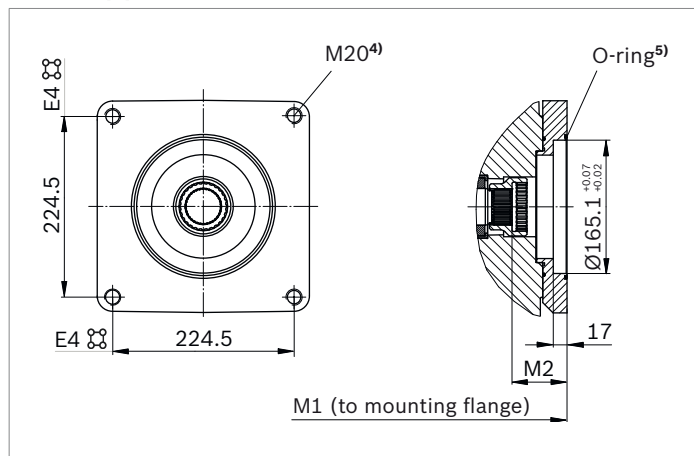

E4A2	NG	M1	M2
without charge pump	175	363.5	58.1
	210	380.8	58.1
	280	423	58.1
with charge pump	175	412.5	58.1
	210	429.8	58.1
	280	461	58.1
E4A4	NG	M1	M2
without charge pump	280	423	68
with charge pump	280	461	68

1) Mounting holes pattern viewed on through drive with control at top.
 2) Hub for splined shaft according to ANSI B92.1a, 30° pressure angle, flat root, side fit, tolerance class 5

3) Hub for splined shaft according to DIN 5480
 4) Thread according to DIN 13; observe the max. tightening torques in the instruction manual.
 5) O-ring included in the scope of delivery

Flange ISO 3019-2 (metric)			Hub for splined shaft ²⁾			Availability across sizes					Code
Diameter	Attachment ¹⁾	Designation	Diameter		Designation	110	145	175	210	280	
80-2	☉	K3	3/4 in	11T 16/32DP	S3	●	●	●	●	○	K3S3
	♂	K5	3/4 in	11T 16/32DP	S3	●	●	●	●	●	K5S3
100-2	♂	L5	7/8 in	13T 16/32DP	S4	●	●	●	●	●	L5S4

● = Available ○ = On request

▼ **80-2**

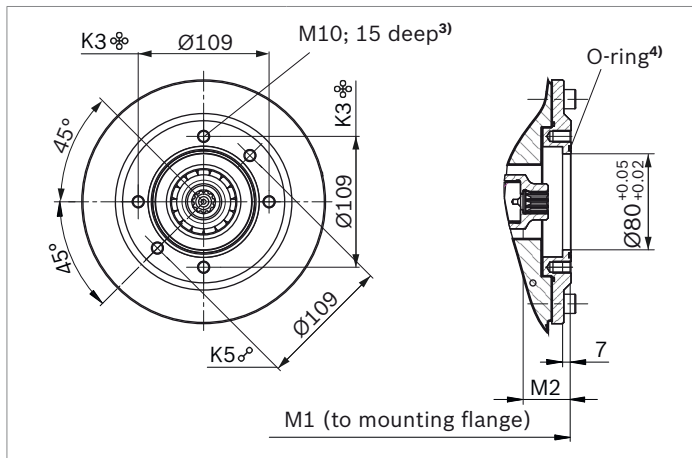

K3S3	NG	M1	M2
without charge pump	110	301	40
	145	326	40
	175	341	40
	210	358	40
with charge pump	145	375	40
	175	390	40
	210	407	40

K5S3	NG	M1	M2
without charge pump	110	301	40
	145	326	40
	175	341	40
	210	358	40
	280	400	40
with charge pump	145	375	40
	175	390	40
	210	407	40
	280	438	40

▼ **100-2**

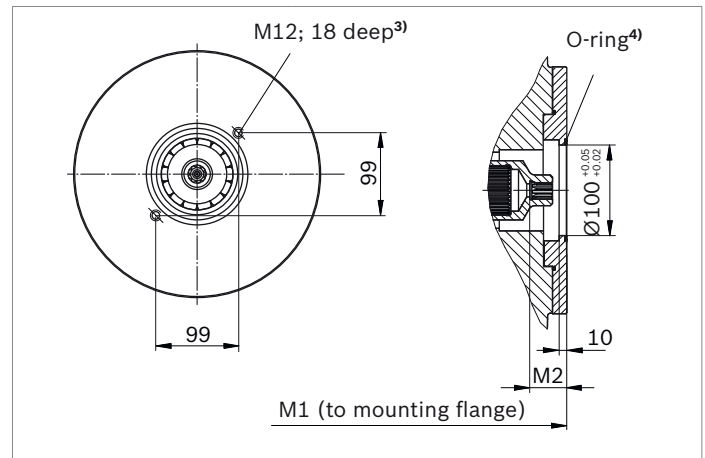

L5S4	NG	M1	M2
without charge pump	110	312	43
	145	337	43
	175	355	43
	210	372	43
	280	414	43
with charge pump	145	386	43
	175	404	43
	210	421	43
	280	452	43

1) Mounting holes pattern viewed on through drive with control at top.

2) Hub for splined shaft according to ANSI B92.1a, 30° pressure angle, flat root, side fit, tolerance class 5

3) Thread according to DIN 13; observe the max. tightening torques in the instruction manual.

4) O-ring included in the scope of delivery

Flange ISO 3019-2 (metric)			Hub for splined shaft ²⁾			Availability across sizes					Code
Diameter	Attachment ¹⁾	Designation	Diameter	Designation		110	145	175	210	280	
160-4		R4	1 1/4 in 14T 12/24DP	S9		●	●	○	●	●	P4S7

● = Available ○ = On request

▼ **160-4**

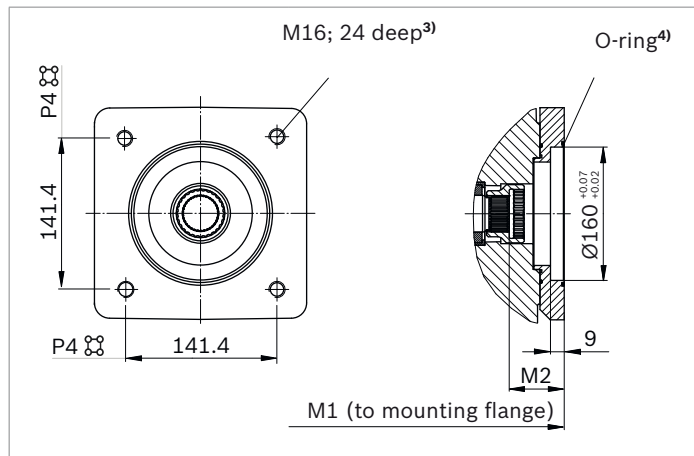

P4S7	NG	M1	M2
without charge pump	110	323	58
	145	348	58
	175	355	58
	210	372	59
	280	414	58
with charge pump	145	397	58
	175	404	58
	210	421	59
	280	452	58

1) Mounting holes pattern viewed on through drive with control at top.
 2) Hub for splined shaft according to ANSI B92.1a, 30° pressure angle, flat root, side fit, tolerance class 5

3) Thread according to DIN 13, observe the general instructions on page 54 for the maximum tightening torques.
 4) O-ring included in the scope of delivery

Flange ISO 3019-2 (metric)			Hub for splined shaft ²⁾			Availability across sizes					Code
Diameter	Attachment ¹⁾	Designation	Diameter		Designation	110	145	175	210	280	
180-4		R4	1 1/2 in	17T 12/24DP	S9	-	-	●	●	●	R4S9
			1 3/4 in	13T 8/16DP	T1	-	-	○	○	●	R4T1

● = Available ○ = On request

▼ **180-4**

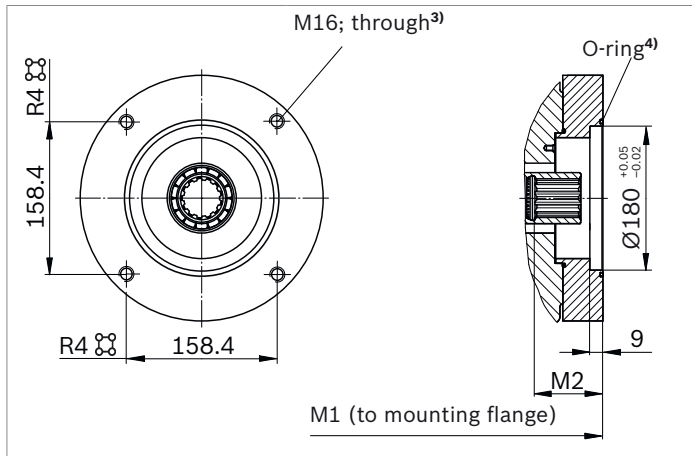

R4S9	NG	M1	M2
without charge pump	175	360	63
	210	377	63
	280	419	69
with charge pump	175	409	63
	210	426	63
	280	457	69

▼ **180-4**

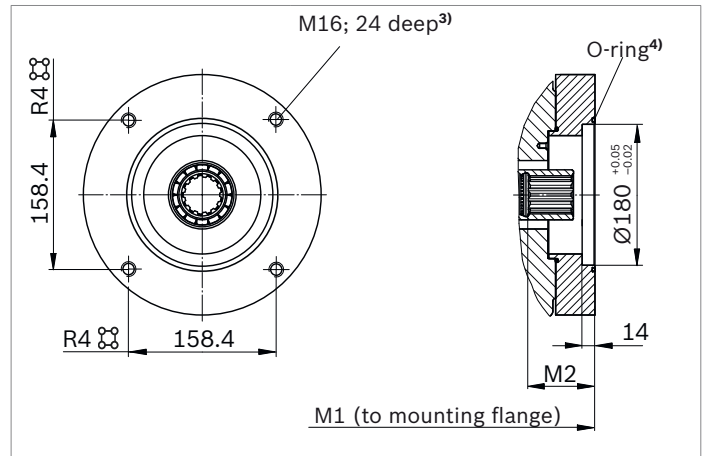

R4T1	NG	M1	M2
without charge pump	280	432	76
with charge pump	280	470	76

1) Mounting holes pattern viewed on through drive with control at top.

2) Hub for splined shaft according to ANSI B92.1a, 30° pressure angle, flat root, side fit, tolerance class 5

3) Thread according to DIN 13, observe the general instructions on page 54 for the maximum tightening torques.

4) O-ring included in the scope of delivery

Overview of mounting options

Through drive ¹⁾			Mounting options – 2nd pump				
Flange SAE J744	Hub for splined shaft	Code	A15VSO/10 A15VLO/10 NG (shaft)	A10VSO/31 NG (shaft)	A10VSO/32 NG (shaft)	A10VO/52 and 53 NG (shaft)	External gear pump
82-2 (A)	5/8 in	A_S2	–	–	–	10, 18 (U)	Series F NG4 to 22 ²⁾
101-2 (B)	7/8 in	B3S4	–	–	–	28 (R, S); 45 (U, W)	Series N NG20 to 36 ²⁾
	1 in	B3S5	–	–	–	45 (R, S); 60, 63 (U, W)	PGH4
127-2 (C)	1 1/4 in	C3S7	–	–	–	85, 100 (U, W)	–
	1 1/2 in	C3S9	–	–	–	85, 100 (S)	PGH5
152-4 (D)	W45	D4A1	110 (A1)	–	–	–	–
	W50	D4A2	145 (A2)	–	–	–	–
165-4 (E)	W50	E4A2	175; 210 (A2)	–	–	–	–
	W60	E4A4	280 (A4)	–	–	–	–
Flange (metric)	Hub for splined shaft	Code	A15VSO/10 A15VLO/10 NG (shaft)	A10VSO/31 NG (shaft)	A10VSO/32 NG (shaft)	A10VO/52 and 53 NG (shaft)	External gear pump
80-2	3/4 in	K_S3	–	18 (S, R)	–	10 (S)	–
100-2	7/8 in	L5S4	–	28 (S, R)	–	–	–
160-4	1 1/4 in	P4S7	–	–	71 (S, R)	–	–
180-4	1 1/2 in	R4S9	–	–	100 (S)	–	–
	1 3/4 in	R4T1	–	140 (S)	140 (S), 180 (R)	–	–
125-4	1 in	M4S5	–	–	45 (S, R)	–	–
140-4	W40	N4Z9	–	–	–	–	–

Mounting situation combination pumps in relation to each other
 Port **S** of the relevant mounting unit in relation to port **S** of the first pump is always used as orientation.
 Below, you will find an example with three attachment pumps:

1st pump	2nd pump	3rd pump
Alignment port S	Mounting angle to 1st pump	Mounting angle to 1st pump
Example: without code	-M270	-M90

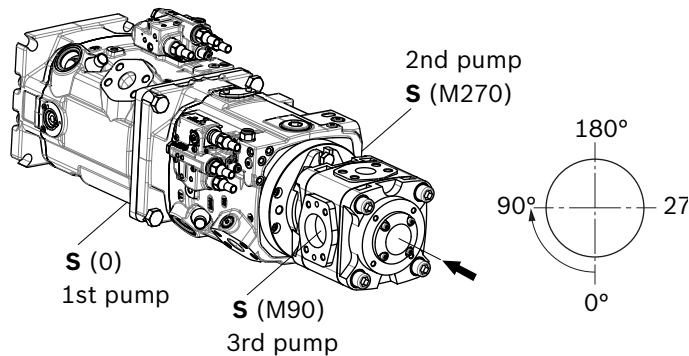

Details of the mounting situation are provided following the order designation for the relevant combination or mounting unit.

Alignment clockwise viewed on through drive.

Order example

A15VSO 280....+A15VSO....145....-**M270**

A15VSO 280....+A15VSO....145....-**M270**+PGH....-**M90**

Notice

- Each through drive is plugged with a **non-pressure-resistant** cover. This means the units must be sealed with a pressure-resistant cover before commissioning. Through drives can also be ordered with a pressure-resistant cover. Please specify in plain text.

1) Additional through drives are available on request

2) Bosch Rexroth recommends special versions of the external gear pumps. Please contact us.

Combination pumps A15V... + A15V...

Total length A

A15VSO (1st pump)	A15VSO (2nd pump)					A15VLO (2nd pump)		
	NG110	NG145	NG175	NG210	NG280	NG175	NG210	NG280
	D4A1	D4A2	E4A2	E4A2	E4A4	E4A2	E4A2	E4A4
NG145	635	656	–	–	–	–	–	–
NG175	648.5	673.5	691	–	–	758	–	–
NG210	665.8	690.8	708.3	725.6	–	775.3	792.6	–
NG280	699	733	750.5	767.8	810	817.5	834.8	866

A15VLO (1st pump)	A15VSO (2nd pump)					A15VLO (2nd pump)		
	NG110	NG145	NG175	NG210	NG280	NG175	NG210	NG280
	D4A1	D4A2	E4A2	E4A2	E4A4	E4A2	E4A2	E4A4
NG175	697.5	722.5	740	–	–	807	–	–
NG210	714.8	739.8	757.3	774.6	–	824.3	841.6	–
NG280	737	771	788.5	805.8	848	855.5	872.8	904

By using combination pumps, it is possible to have independent circuits without the need for splitter gearboxes.

When ordering combination pumps, the type designations of the 1st and 2nd Pump must be connected with a "+" and the mounting situation must be added as described on page 61.

Order example:

A15VSO280LRDRA00/11MRVE4A41SE4A40-0+

A15VSO280LRDRA00/11MRVE4A41SU0000-0

A tandem pump, with two pumps of equal size, is permissible without additional supports, assuming that the dynamic mass acceleration does not exceed maximum 10 g (= 98.1 m/s²).

For combination pumps consisting of more than two pumps, the mounting flange must be calculated for the permissible mass torque.

Notice

The combination pump type code is shown in shortened form in the order confirmation.

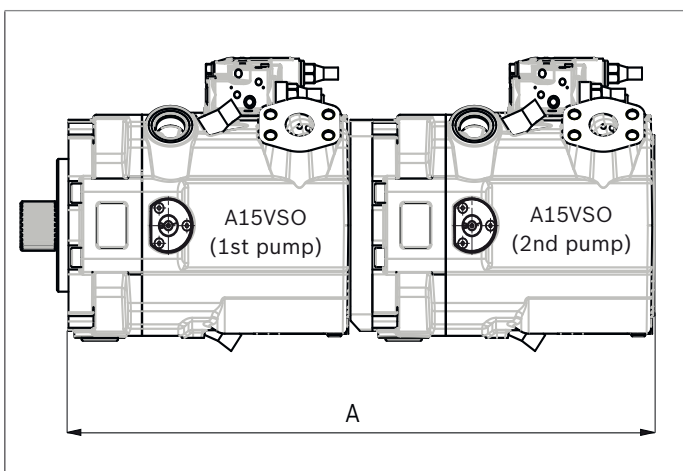

Connector for solenoids

HIRSCHMANN DIN EN 175 301-803-A /ISO 4400

Without bidirectional suppressor diode _____H

Type of protection according to DIN/EN 60529 _____ IP65

The seal ring in the cable fitting is suitable for lines of diameter 4.5mm to 10mm.

The plug-in connector is not included in the scope of delivery.

This can be supplied by Bosch Rexroth on request (material number: R902602623).

Notice

If necessary, you can change the position of the connector by turning the solenoid body. The procedure is described in the instruction manual.

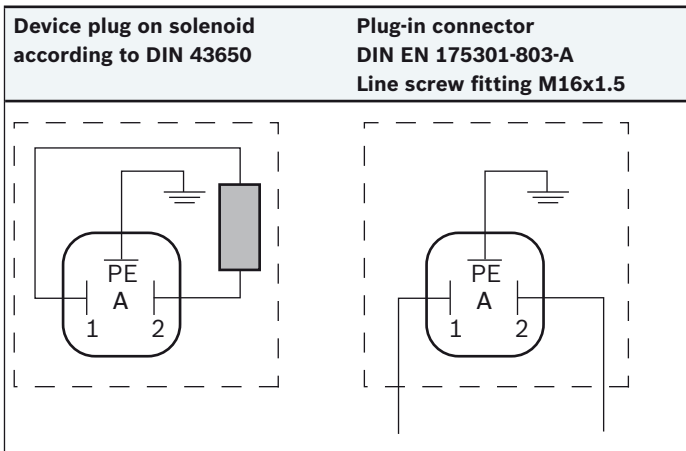
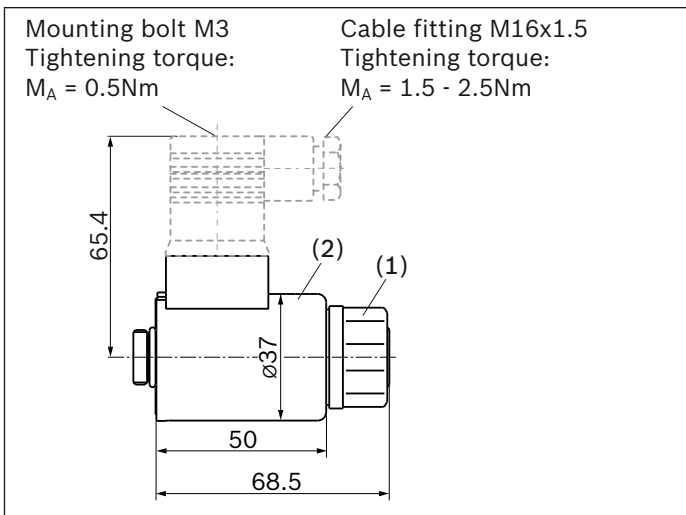

Installation instructions

General

The axial piston unit must be filled with hydraulic fluid and air bled during commissioning and operation. This must also be observed following a longer standstill as the axial piston unit may empty via the hydraulic lines.

Particularly in the installation position "drive shaft upwards", filling and air bleeding must be carried out completely as there is, for example, a danger of dry running.

The case drain leakage in the housing area must be directed to the reservoir via the highest available drain port (**T₁**, **T₂**, **T₃**).

For combination pumps, the leakage must be drained off at each single pump.

If a shared drain line is used for several units, make sure that the respective case pressure in each unit is not exceeded. The shared drain line must be dimensioned to ensure that the maximum permissible case pressure of all connected units is not exceeded in any operating conditions, particularly at cold start. If this is not possible, separate drain line must be laid, if necessary.

To achieve favorable noise values, decouple all connecting lines using elastic elements and avoid above-reservoir installation.

In all operating conditions, the suction and drain lines must flow into the reservoir below the minimum fluid level.

The permissible suction height h_s results from the total pressure loss. However, it must not be higher than $h_{s\ max} = 800\text{ mm}$. The minimum suction pressure at port **S** must also not fall below 0.8bar abs.

(without charge pump) or 0.7bar abs. (with charge pump) during operation and during a cold start.

Make sure to provide adequate distance between suction line and drain line for the reservoir design. This prevents the heated return flow from being drawn directly back into the suction line.

Notice

In certain installation positions, an influence on the adjustment or control can be expected. Gravity, dead weight and case pressure can cause minor characteristic shifts and changes in actuating time.

Installation position

See the following examples **1** to **9**.

Further installation positions are available upon request.
Recommended installation position: **1** and **2**

Below-reservoir installation (standard)

Below-reservoir installation means that the axial piston unit is installed outside of the reservoir below the minimum fluid level.

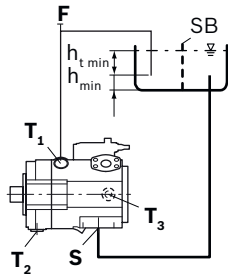
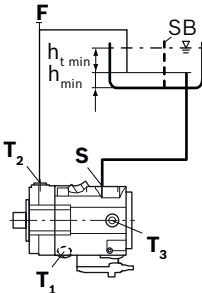
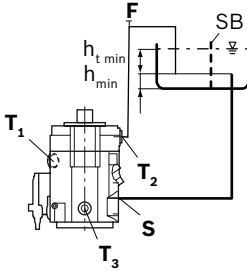
Installation position	Air bleed	Filling
1 	F, T₁	S + T₁
2 	F, T₂	S + T₂
3 	F, T₂	S + T₂
Key		
L	Filling / Air bleeding	
S	Suction port	
T	Drain port	
SB	Baffle (baffle plate)	
$h_{t\ min}$	Minimum required immersion depth (200 mm)	
h_{min}	Minimum required distance to reservoir bottom (100 mm)	
$h_{ES\ min}$	Minimum height required to prevent axial piston unit from draining (25 mm)	
$h_{s\ max}$	Maximum permissible suction height (800 mm)	

Above-reservoir installation

Above-reservoir installation means that the axial piston unit is installed above the minimum fluid level of the reservoir. To prevent the axial piston unit from draining, a height difference $h_{ES\ min}$ of at least 25mm at port **T**₂ is required in position 6. Observe the max. permissible suction height $h_{S\ max} = 800\text{mm}$.

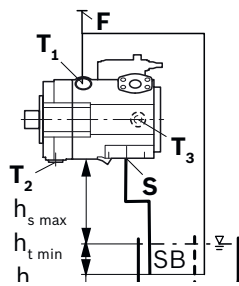
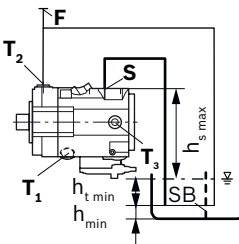
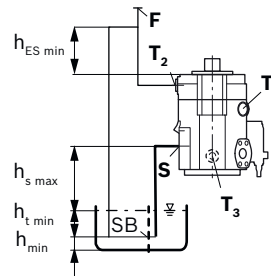
Installation position	Air bleed	Filling
<p>4</p> 	F	T ₁ (F)
<p>5</p> 	F	T ₂ (F)
<p>6</p> 	F	T ₂ (F)

Inside-reservoir installation

Inside-reservoir installation is when the axial piston unit is installed in the reservoir below the minimum fluid level. The axial piston unit is completely below the hydraulic fluid. If the minimum fluid level is equal to or below the upper edge of the pump, see chapter "**Above-reservoir installation**".

Axial piston units with electric components (e.g. electric controls, sensors) must not be installed in a reservoir below the fluid level.

Exception

Installing the pump at an adequate E2/E6 control only with HIRSCHMANN connector and if mineral hydraulic fluids are used and the fluid temperature in the reservoir does not exceed 80°C.

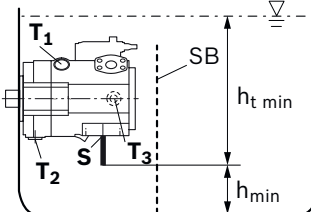
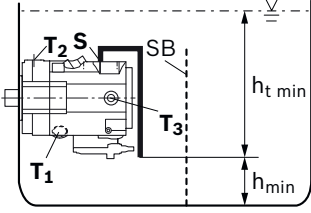
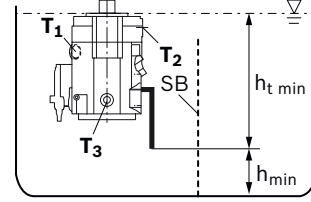
Installation position	Air bleed	Filling
<p>7</p> 	Via the highest available port T ₁	Automatically via the open port T ₁ due to the position under the hydraulic fluid level
<p>8</p> 	Via the highest available port T ₂	Automatically via the open port T ₂ due to the position under the hydraulic fluid level
<p>9</p> 	Via the highest available port T ₂	Automatically via the open port T ₂ due to the position under the hydraulic fluid level

Notice

Port **F** is part of the external piping and must be provided on the customer side to make filling and air bleeding easier.

Project planning notes

- ▶ The A15VS(L)O axial piston variable pump is intended to be used in open circuit.
- ▶ The project planning, assembly and commissioning of the axial piston unit require the involvement of qualified skilled persons.
- ▶ Before using the axial piston unit, please read the corresponding instruction manual completely and thoroughly. If necessary, this can be requested from Bosch Rexroth.
- ▶ Before finalizing your design, please request a binding installation drawing.
- ▶ The specified data and notes contained herein must be observed.
- ▶ Depending on the operating conditions of the axial piston unit (working pressure, fluid temperature), the characteristic curve may shift.
- ▶ The characteristic curve may also shift due to the dither frequency or control electronics.
- ▶ Preservation: Our axial piston units are supplied as standard with preservative protection for a maximum of 12 months. If longer preservation is required (maximum 24 months), please specify this in plain text when placing your order. The preservation periods apply under optimal storage conditions, which can be found in data sheet 90312 or in the instruction manual.
- ▶ Not all versions of the product are approved for use in a safety function according to ISO 13849. Please consult the proper contact at Bosch Rexroth if you require reliability parameters (e.g. $MTTF_d$) for functional safety.
- ▶ Depending on the type of control used, electromagnetic effects can be produced when using solenoids. Use of the recommended direct current (DC) on the electromagnet does not produce any electromagnetic interference (EMI) nor is the electromagnet influenced by EMI. Potential electromagnetic interference (EMI) exists if the solenoid is energized with a modulated direct current (e.g. PWM signal). The machine manufacturer should conduct appropriate tests and take appropriate measures to ensure that other components or operators (e.g. with a pacemaker) are not affected by this potentiality.
- ▶ Pressure controllers are not safeguards against pressure overload. Be sure to add a pressure relief valve to the hydraulic system.
- ▶ For drives that are operated for a long period with constant rotational speed, the natural frequency of the hydraulic system can be stimulated by the excitation frequency of the pump (rotational speed frequency $\times 9$). This can be prevented with suitably designed hydraulic lines.
- ▶ Working ports:
 - The ports and fastening threads are designed for the specified maximum pressure. The machine or system manufacturer must ensure that the connecting elements and lines correspond to the specified application conditions (pressure, flow, hydraulic fluid, temperature) with the necessary safety factors.
 - The working ports and function ports are only intended to accommodate hydraulic lines.

Safety instructions

- ▶ During and shortly after operation, there is a risk of burning on the axial piston unit and especially on the solenoids. Take the appropriate safety measures (e.g. by wearing protective clothing).
- ▶ Moving parts in control equipment (e.g. valve spools) can, under certain circumstances, get stuck in position as a result of contamination (e.g. contaminated hydraulic fluid, abrasion, or residual dirt from components). As a result, the hydraulic fluid flow and the build-up of torque in the axial piston unit can no longer respond correctly to the operator's specifications. Even the use of various filter elements (external or internal flow filtration) will not rule out a fault but merely reduce the risk. The machine/system manufacturer must test whether remedial measures are needed on the machine for the application concerned in order to bring the driven consumer into a safe position (e.g. safe stop) and ensure any measures are appropriately implemented.

Bosch Rexroth AG

An den Kelterwiesen 14
72160 Horb a.N., Germany
Tel. +49 7451 92-0
info.ma@boschrexroth.de
www.boschrexroth.com

© Bosch Rexroth AG 2019. All rights reserved, also regarding any disposal, exploitation, reproduction, editing, distribution, as well as in the event of applications for industrial property rights. The data specified within only serves to describe the product. No statements concerning a certain condition or suitability for a certain application can be derived from our information. The information given does not release the user from the obligation of own judgment and verification. It must be remembered that our products are subject to a natural process of wear and aging.