

Directional spool valves, pilot-operated,
with electro-hydraulic actuation

Type WEH...=UR

RE 24802

Edition: 2016-12

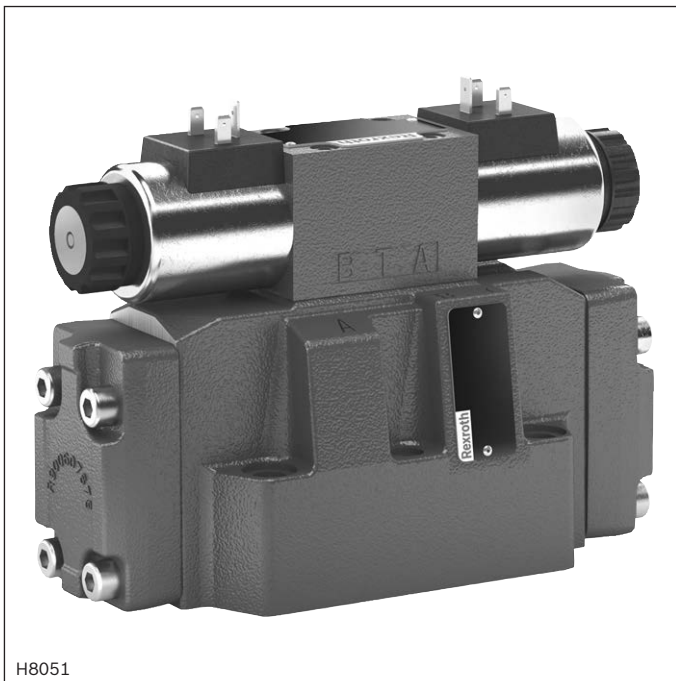

- ▶ Solenoid coil is an approved component with UR-marking according to UL 906
- ▶ Size 10 ... 32
- ▶ Component series 4X; 6X; 7X
- ▶ Maximum operating pressure 350 bar [5076 psi]
- ▶ Maximum flow 1100 l/min [290 US gpm]

**Features**

- ▶ 4/3-, 4/2- or 3/2-way version
- ▶ For subplate mounting
- ▶ Porting pattern according to ISO 4401
- ▶ Spring or pressure centering, spring end position or hydraulic end position
- ▶ Wet-pin DC or AC solenoids, optional
- ▶ Electrical connection as individual connection
- ▶ Concealed manual override
- ▶ Optional versions:
 - Switching time adjustment
 - Preload valve in channel P of the main valve
 - Stroke setting and/or spool position monitoring

Contents

Features	1
Ordering code	2 ... 4
Symbols	5 ... 9
Function, section	10, 11
Pilot oil supply	12, 13
Technical data	14 ... 16
Switching times	17
Characteristic curves, performance limits	18 ... 28
Dimensions	29 ... 34
Stroke setting, mounting options	35, 36
Switching time adjustment	37
Pressure reducing valve "D3"	37
Preload valve (not for NG10)	38
Project planning information	39
Further information	39

Ordering code

01	02	03	04	05	06	07	08	09	10	11	12	13	14	15	16	17	18	19	20	21	22
	WEH					/				N9				K4		/				= UR	*

01	Up to 280 bar	no code
	Up to 350 bar	H -
02	3-way version	3
	4-way version	4

Types of actuation

03	Electro-hydraulic	WEH
----	-------------------	------------

Size

04	NG10	10
	NG16	16
	NG25 (version "WEH 22")	22
	NG25 (version "WEH 25")	25
	NG32	32

Control spool return in the main valve

05	By means of springs	no code
	Hydraulic ¹⁾	H

06	For symbols, see page 5 and 6	
----	-------------------------------	--

07	Component series 40 ... 49 (40 ... 49: unchanged installation and connection dimension) – NG10	4X
	Component series 60 ... 69 (60 ... 69: unchanged installation and connection dimensions) – NG25 ("WEH 25") and NG32	6X
	Component series 70 ... 79 (70 ... 79: unchanged installation and connection dimensions) – NG16 (from series 72) and NG25 ("WEH 22")	7X

Control spool return in the pilot control valve with 2 switching positions and 2 solenoids

(Only possible with symbols A, B, C, D, K, Z and hydraulic control spool return in the main valve)

08	With spring return	no code
	Without spring return	O
	Without spring return with detent	OF

Pilot control valve

09	High-power valve (data sheet 23208)	6E
----	-------------------------------------	-----------

10	Direct voltage 12 V	G12
	Direct voltage 24 V	G24
	AC voltage 110 V or 120 V, 50/60 Hz	W110

11	With concealed manual override	N9 ²⁾
----	---------------------------------------	-------------------------

Pilot oil flow

12	External pilot oil supply, external pilot oil return ³⁾	no code
	Internal pilot oil supply, external pilot oil return ^{3; 4)}	E
	Internal pilot oil supply, internal pilot oil return ⁴⁾	ET
	External pilot oil supply, internal pilot oil return ³⁾	T
	(Version "ET" and "T" with 3-spool position valve, pressure-centered only possible if $p_{St} \geq 2 \times p_{tank} + p_{St\ min!}$)	

Switching time adjustment

13	Without switching time adjustment	no code
	Switching time adjustment as supply control	S
	Switching time adjustment as discharge control	S2

Ordering code

01	02	03	04	05	06	07	08	09	10	11	12	13	14	15	16	17	18	19	20	21	22
	WEH					/				N9				K4	/					= UR	*

Electrical connection

14	Individual connection	
	Without mating connector; connector DIN EN 175301-803	K4 ⁵⁾

Spool position monitoring

15	Without position switch	no code
	- Inductive position switch type QM	
	Monitored spool position "a"	QMAG24
	Monitored spool position "b"	QMBG24
	Monitored rest position	QM0G24
	- Inductive proximity sensor type QS	
	Monitored spool position "a"	QSAG24W
	Monitored spool position "b"	QSBG24W
	Monitored spool position "0"	QS0G24W
	Monitored spool position "0" and "a"	QS0AG24W
	Monitored spool position "0" and "b"	QS0BG24W
	Monitored spool position "a" and "b"	QSABG24W
	For more information, see data sheet 24830	

Stroke setting

16	For ordering code, see page 35 and 36	
----	---------------------------------------	--

Throttle insert

17	Without throttle insert	no code
	With throttle insert ⁶⁾ :	
	Throttle Ø 0.8 mm [0.0315 inch]	B08
	Throttle Ø 1.0 mm [0.0394 inch]	B10
	Throttle Ø 1.2 mm [0.0472 inch]	B12
	Throttle Ø 1.5 mm [0.0591 inch]	B15
	Throttle Ø 2.0 mm [0.0787 inch]	B20
	Throttle Ø 2.5 mm [0.0984 inch]	B25

Preload valve (not for NG10)

18	Without preload valve	no code
	With preload valve ($p_c = 4.5 \text{ bar}$ [65 psi])	P4,5
19	Without pressure reducing valve	no code
	With pressure reducing valve	D3 ⁷⁾

Seal material

20	NBR seals	no code
	FKM seals	V
	Observe compatibility of seals with hydraulic fluid used. (Other seals upon request)	
21	Solenoid coil is an approved component with UR-marking according to UL 906	= UR
22	For further information, see the plain text	*

p_{pilot} = pilot pressure
 $p_{\text{pilot min}}$ = minimum pilot pressure
 p_{tank} = tank pressure
 p_c = cracking pressure

Explanation of the footnotes, see page 4.

Ordering code

- 1) ▶ 2 spool positions (hydraulic end position):
only symbols C, D, K, Z, Y
 - ▶ 3 switching positions (hydraulically centered):
only NG16, NG25 ("4W.H 25") and NG32
- 2) The manual override cannot be allocated a safety function. The manual override units may only be used up to a tank pressure of 50 bar.
- 3) Pilot oil supply X or return **external**:
 - ▶ The maximum admissible operating parameters of the pilot control valve must be observed (see data sheet 23208)!
 - ▶ Minimum pilot pressure: please observe page 15!
 - ▶ Maximum pilot pressure: please observe page 15!
- 4) Pilot oil supply **internal** (version "ET" and "E"):
 - ▶ Minimum pilot pressure: please observe page 15!
 - ▶ Maximum pilot pressure: please observe page 15!
With a higher pilot pressure, use of a **pressure reducing valve "D3"** is required (if it is not used pilot pressure = operating pressure at the port!).
 - ▶ In order to prevent inadmissibly high pressure peaks, a **"B10" throttle insert** has to be provided in port P of the pilot control valve (see page 13).
 - ▶ In connection with version "H", the **pressure reducing valve "D3"** is also required.
- 5) Mating connectors, separate order, see data sheet 23208 and 08006
- 6) When the admissible valve performance limits are exceeded, installation of throttle inserts is to be intended (performance limits see page 21 to 28).
- 7) Only in connection with the **"B10"** throttle insert

Symbols: 2 spool positions

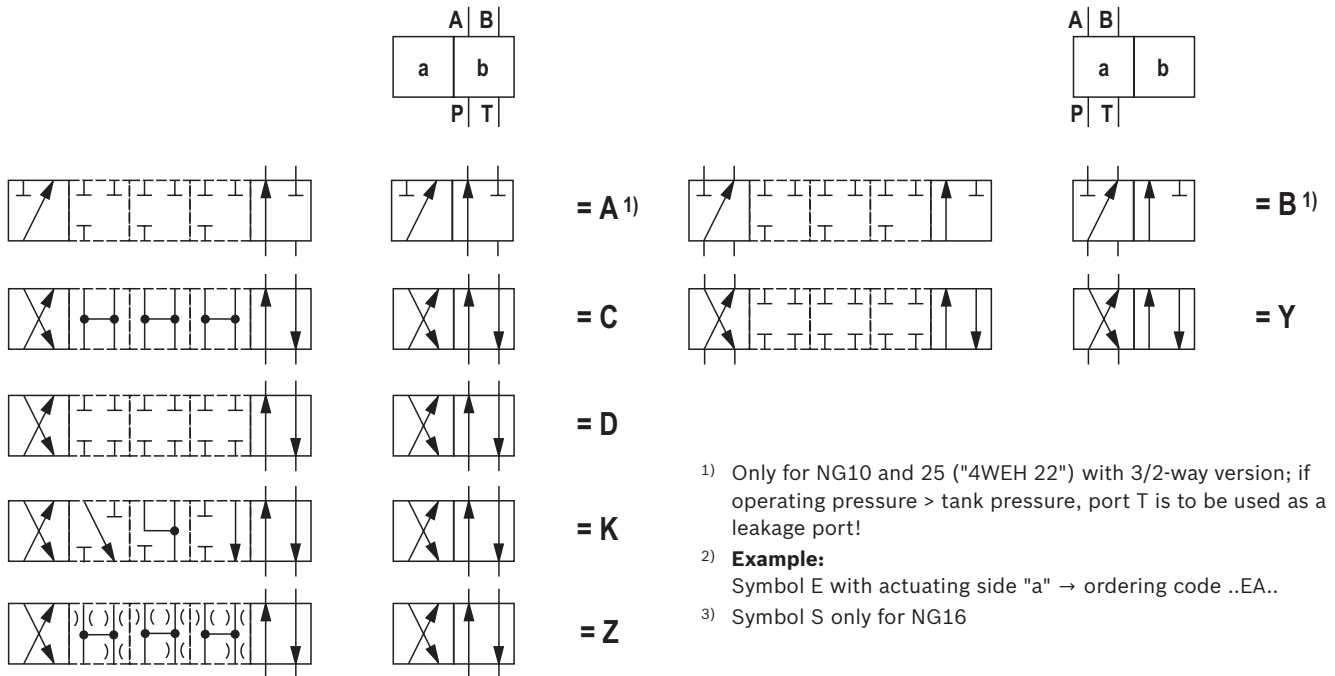

- 1) Only for NG10 and 25 ("4WEH 22") with 3/2-way version; if operating pressure > tank pressure, port T is to be used as a leakage port!
- 2) **Example:**
Symbol E with actuating side "a" → ordering code ..EA..
- 3) Symbol S only for NG16

Ordering code		
Symbol	Control spool return	Type of actuation
A ¹⁾ , C, D, K, Z	../..	
	..H../..	
	..H../O	
	..H../OF	
B ¹⁾ , Y	../..	
	..H../..	

Symbols: 3 spool positions

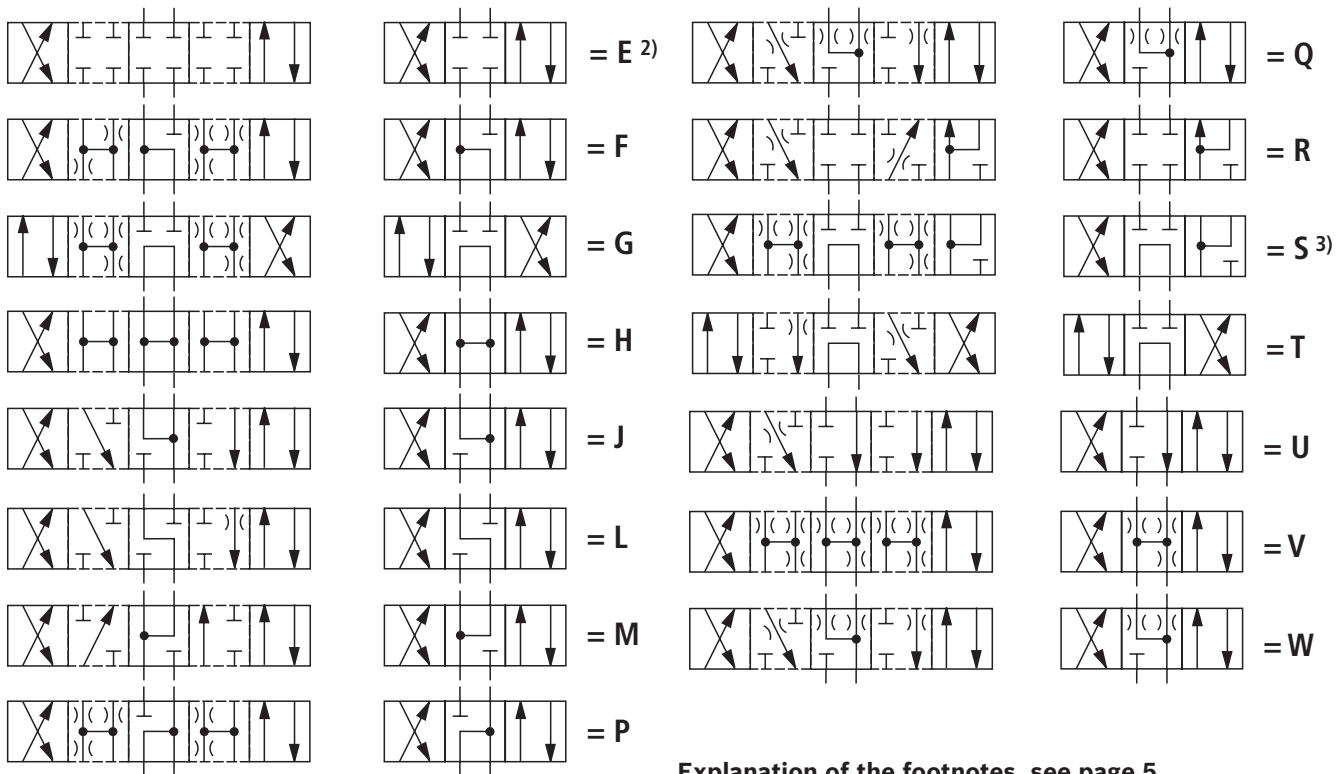

Explanation of the footnotes, see page 5.

Symbol	Ordering code	Actuating side	Control spool return	Type of actuation
E, F, G, H, J, L, M, P, Q, R, S, T, U, V, W			../..	
	.A			
	.B			
			..H../..	
			H.A	
			H.B	

Symbols for valves with 2 spool positions

	Valve with spring end position	Valve with hydraulic end position			
<p>X = external; Y = external</p>	<p>Type WEH.../..</p>	<p>Type WEH . H../...</p>	<p>Type WEH . H../O...</p>	<p>Type WEH . H../OF...</p>	
	<p>X = internal; Y = external</p>	<p>Type WEH.../...E...</p>	<p>Type WEH . H../...E...</p>	<p>Type WEH . H../O...E...</p>	<p>Type WEH . H../OF...E...</p>
		<p>X = internal; Y = internal</p>	<p>Type WEH.../...ET...</p>	<p>Type WEH . H../...ET...</p>	<p>Type WEH . H../O...ET...</p>

Symbols for valves with 2 spool positions

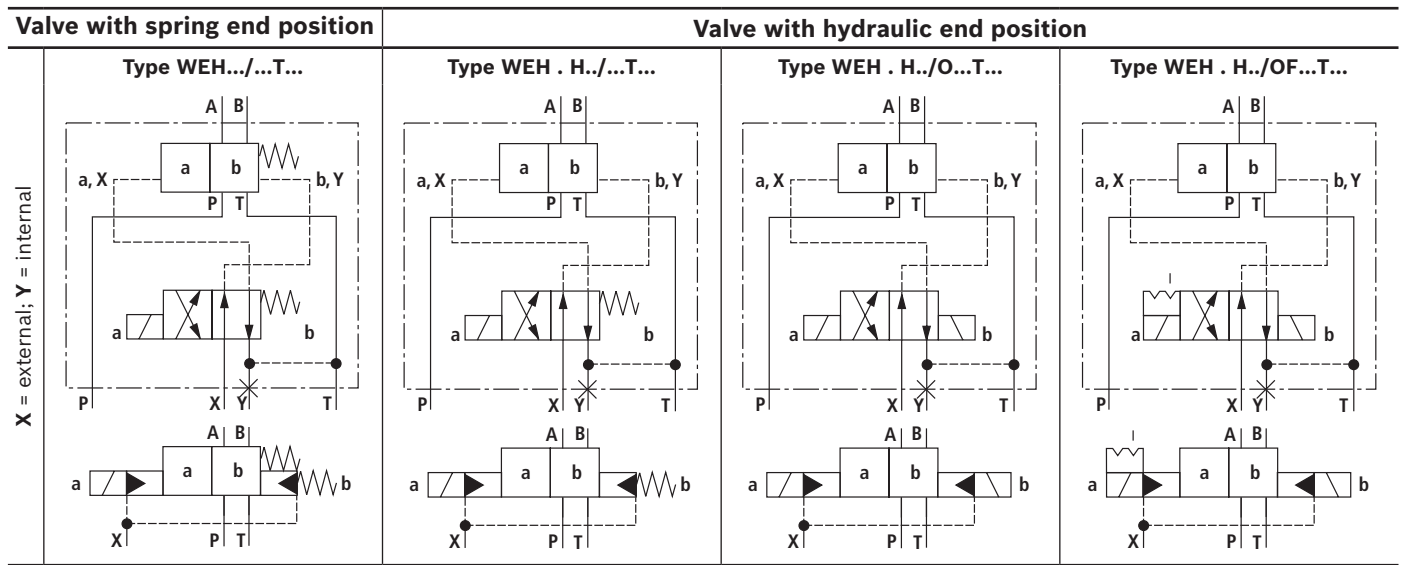

Symbols for valves with 3 spool positions

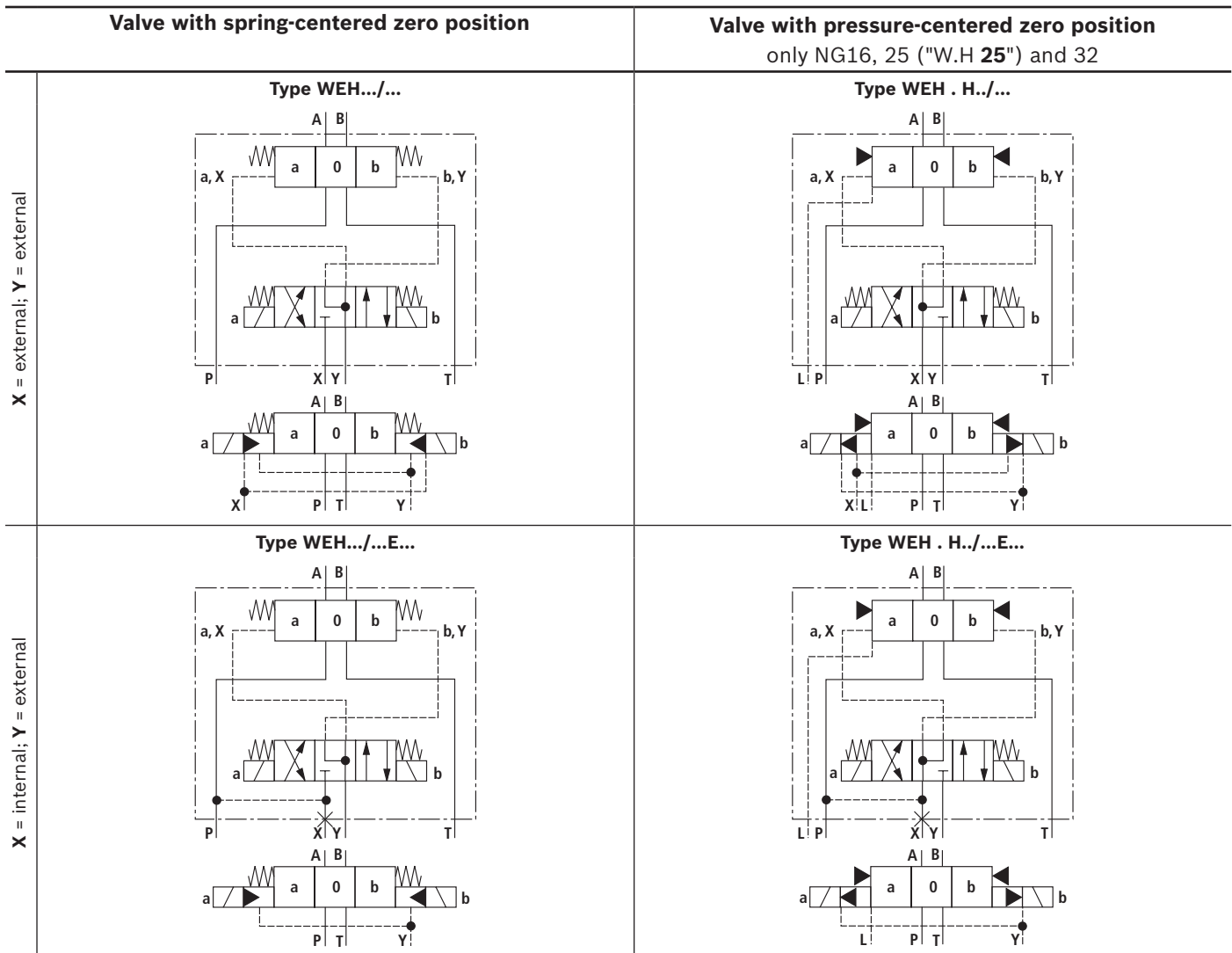

Symbols for valves with 3 spool positions

	Valve with spring-centered zero position	Valve with pressure-centered zero position only NG16, 25 ("W.H 25") and 32
X = internal; Y = internal	<p>Type WEH.../...ET...</p>	<p>Type WEH . H./...ET...</p>
X = external; Y = internal	<p>Type WEH.../...T...</p>	<p>Type WEH . H./...T...</p>

Notice:

3-spool position valves, pressure-centered, preferably with external pilot oil supply and/or return ("no code", "E")
 For preconditions for internal pilot oil supply and/or return ("ET", "T"), see page 4 and 14.

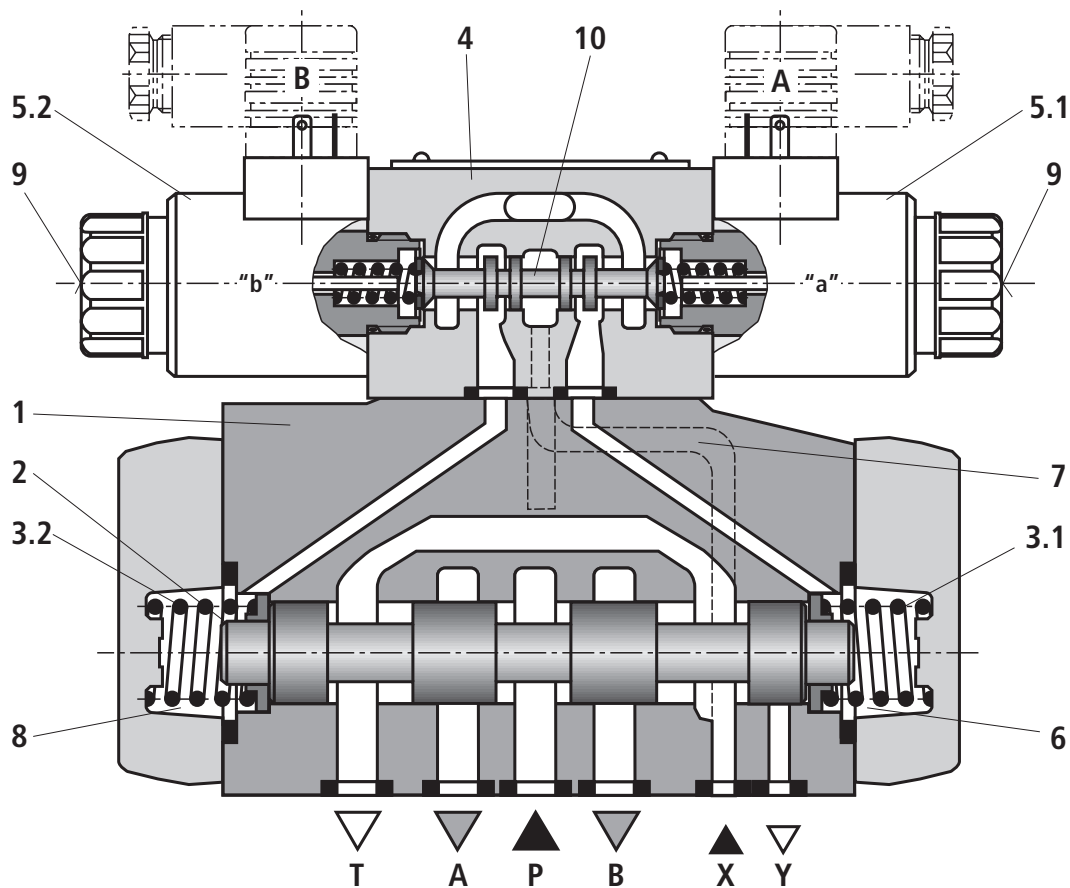
Function, section: Type WEH**Directional valves type WEH...**

The valve type WEH is a directional spool valve with electro-hydraulic actuation. It controls the start, stop and direction of a flow.

The directional valves basically consist of the main valve with housing (1), the main control spool (2), one or two return springs (3.1) and (3.2), as well as the pilot control valve (4) with one or two solenoids "a" (5.1) and/or "b" (5.2).

The main control spool (2) in the main valve is held in the zero or initial position by the springs or by means of pressurization. In the initial position, the two spring chambers (6) and (8) are connected with the tank in a depressurized form via the pilot control valve (4). Via the control line (7), the pilot control valve is supplied with pilot oil. Supply can be implemented internally or externally (externally via port X). Upon actuation of the pilot control valve, e.g. solenoid "a", the pilot control spool (10) is moved to the left and thus, the spring chamber (8) is pressurized with pilot pressure. The spring chamber (6) remains depressurized.

The pilot pressure acts on the left side of the main control spool (2) and moves it against the spring (3.1). This connects port P with B and A with T in the main valve.

On switching off of solenoid, the pilot control spool (10) returns to its initial position (except impulse spool). The spring chamber (8) is unloaded to the tank.

The pilot oil return is implemented internally (via channel T) or externally (via channel Y).

An optional manual override (9) allows for moving of the pilot control spool (10) without solenoid energization.

Notes:

The return springs (3.1) and (3.2) in the spring chambers (6) and (8) hold the main control spool (2) in central position without pilot pressure even with, for example, vertical valve positioning.

Due to the design principle, internal leakage is inherent to the valves, which may increase over the life cycle.

For pilot oil supply, see page 12 and 13.

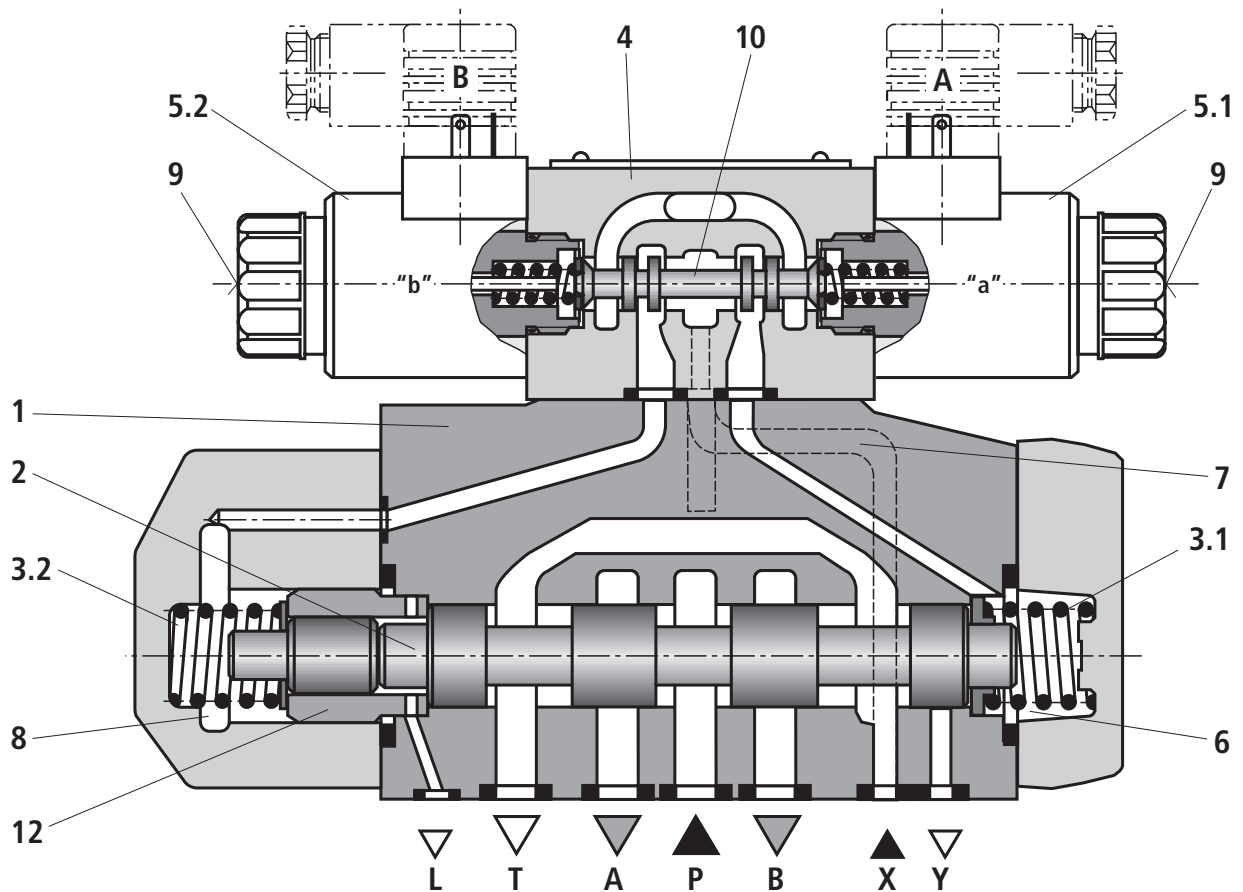
Function, section: Type WEH...H**4/3 directional valve with pressure centering of the main control spool, type WEH...H**

The main control spool (2) in the main valve is kept in the zero position by pressurization of the two front faces. One centering bush (12) rests on the housing and fixes the control spool position.

By pressure relief of one front face, the main control spool (2) is moved to the switching position.

The unloaded control spool face displaces the returning pilot oil into channel Y (external) via the pilot control valve.

Notes:

The springs (3.1) and (3.2) do not have a return function in this version. They hold the main control spool (2) in central position in the depressurized condition and with horizontal installation.

Pilot oil supply (schematic illustration)

NG10

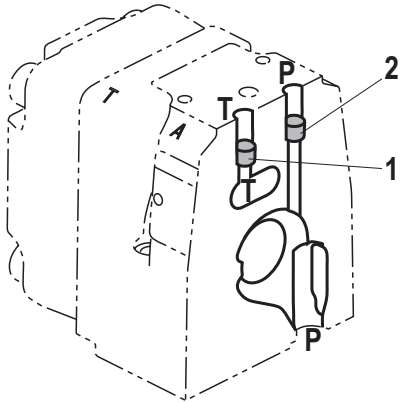

NG16

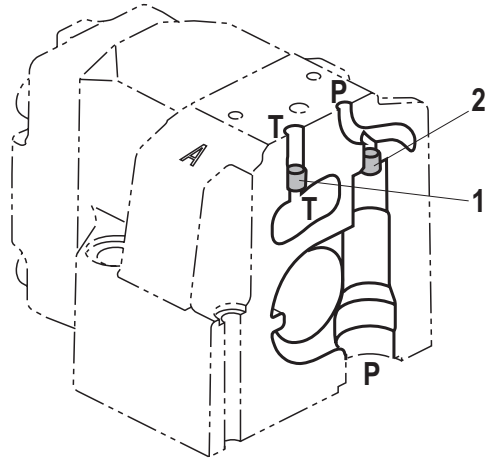

NG25 ("W.H 22")

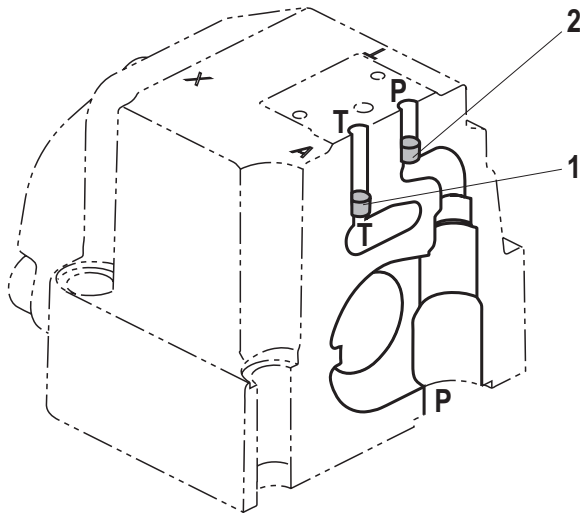

NG25 ("W.H 25")

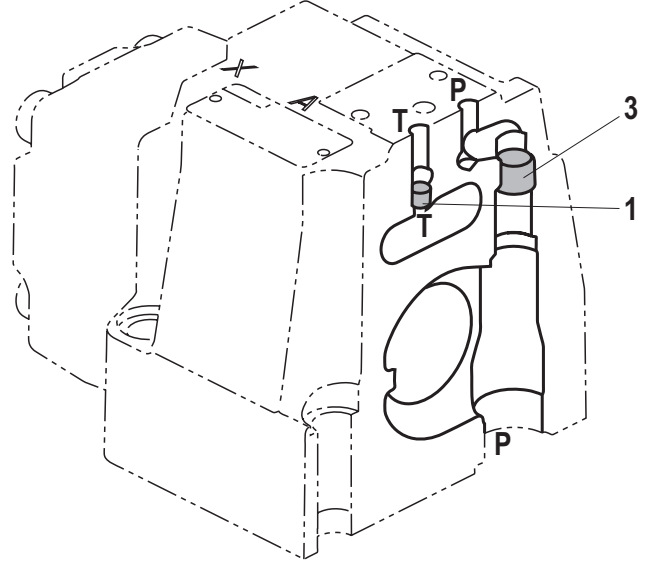

NG32

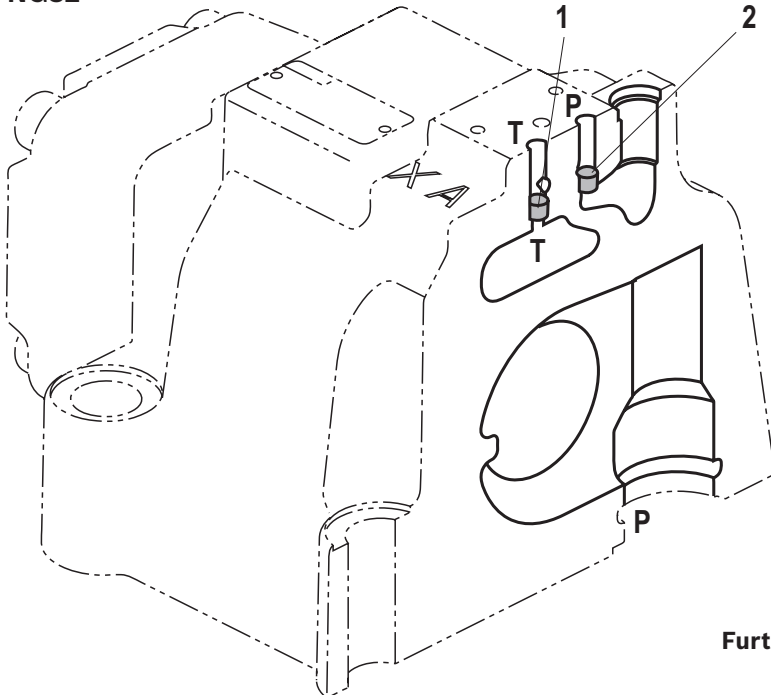

- 1 Plug screw M6 according to DIN 906, wrench size 3 – pilot oil return
- 2 Plug screw M6 according to DIN 906, wrench size 3 – pilot oil supply
- 3 Plug screw M12 x 1.5 according DIN 906, wrench size 6 – pilot oil supply

Pilot oil supply

external: 2, 3 closed
 internal: 2, 3 open

Pilot oil return

external: 1 closed
 internal: 1 open

Further explanations on page 13.

Pilot oil supply

Type WEH...

The pilot oil supply is implemented **externally** - via channel X - from a separate pressure supply.

The pilot oil return is implemented **externally** - via channel Y - into the tank.

Type WEH...E...

The pilot oil supply is implemented **internally** from channel P of the main valve. (see page 14, footnotes ⁵⁾ and ⁶⁾)

The pilot oil return is implemented **externally** - via channel Y - into the tank. In the subplate, port X is closed.

Type WEH...ET...

The pilot oil supply is implemented **internally** from channel P of the main valve.

The pilot oil return is implemented **internally** - via channel T - into the tank. In the subplate, ports X and Y are closed.

Type WEH...T...

The pilot oil supply is implemented **externally** - via channel X - from a separate pressure supply.

The pilot oil return is implemented **internally** - via channel T - into the tank. In the subplate, port Y is closed.

Throttle insert

Use of the throttle insert (5) is necessary if the pilot oil supply in channel P of the pilot control valve is to be limited (see below).

The throttle insert (5) is inserted in channel P of the pilot control valve.

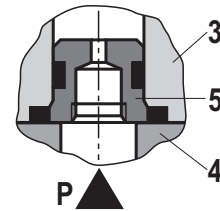

Notes:

The modification of the pilot oil supply may only be performed by authorized specialists or at the factory!

- ▶ Pilot oil supply X or return Y **external**:
 - The maximum admissible operating parameters of the pilot control valve must be observed (see data sheet 23208)!
 - Maximum pilot pressure: please observe page 15!
- ▶ Pilot oil supply **internal** (version "ET" and "E"):
 - Minimum pilot pressure: please observe page 14!
 - In order to prevent inadmissibly high pressure peaks, a **"B10" throttle insert** has to be provided in port P of the pilot control valve (see above).
 - In connection with version "H", the **pressure reducing valve "D3"** (see page 37) is also required.

3 Pilot control valve

4 Main valve

5 Throttle insert

Technical data

(For applications outside these parameters, please consult us!)

general							
Sizes	NG	10	16	25 "W.H 22"	25 "W.H 25"	32	
Weight, approx.	▶ Valve with one solenoid	kg [lbs]	6.4 [14.1]	8.5 [18.7]	11.5 [25.3]	17.6 [38.8]	17.6 [38.8]
	▶ Valve with two solenoids, spring-centered	kg [lbs]	6.8 [15.0]	8.9 [19.6]	11.9 [26.2]	19.0 [41.9]	41.0 [90.4]
	▶ Valve with two solenoids, pressure-centered	kg [lbs]	6.8 [15.0]	8.9 [19.6]	11.9 [26.2]	19.0 [41.9]	41.0 [90.4]
	▶ Valve with hydraulic actuation (type WH...)	kg [lbs]	5.5 [12.1]	7.3 [16.1]	10.5 [23.1]	16.5 [36.4]	39.5 [87.1]
	▶ Switching time adjustment "S" and "S2"	kg [lbs]	0.8 [1.8]	0.8 [1.8]	0.8 [1.8]	0.8 [1.8]	0.8 [1.8]
	▶ Pressure reducing valve "D3"	kg [lbs]	0.4 [0.9]	0.4 [0.9]	0.4 [0.9]	0.4 [0.9]	0.4 [0.9]
Installation position	Any; horizontal with valves with hydraulic control spool return "H" and symbol A, B, C, D, K, Z, Y. With suspended installation, higher sensitivity to contamination – horizontal is recommended.						
Ambient temperature range	°C [°F]	-20 ... +70 [-4 ... +158] (NBR seals) -15 ... +70 [+5 ... +158] (FKM seals)					
Storage temperature range	°C [°F]	+5 ... +40 [+41 ... +104]					
Surface protection (valve body)	Coating, layer thickness max. 100 µm						
Maximum storage time	Years	1					

hydraulic								
Maximum operating pressure								
▶ Port P, A, B	Type WEH	bar [psi]	280 [4061]	280 [4061]	280 [4061]	280 [4061]	280 [4061]	
	Type H-WEH	bar [psi]	350 [5076]	350 [5076]	350 [5076]	350 [5076]	350 [5076]	
▶ Port T	External pilot oil return Y	Type WEH	bar [psi]	280 [4061]	250 [3626]	250 [3626]	250 [3626]	250 [3626]
		Type H-WEH		315 [4568]	250 [3626]	250 [3626]	250 [3626]	250 [3626]
	Internal pilot oil return Y ¹⁾	Type H-WEH, WEH	bar [psi]	180 [2610] with direct voltage 160 [2320] with alternating voltage				
▶ Port Y	External pilot oil return	Type H-WEH, WEH	bar [psi]	180 [2610] with direct voltage 160 [2320] with alternating voltage				
Hydraulic fluid			see table on page 16					
Hydraulic fluid temperature range (at the valve working ports)			°C [°F]	-20 ... +80 [-4 ... +176] (NBR seals) -15 ... +80 [+5 ... +176] (FKM seals)				
Viscosity range			mm ² /s [SUS]	2.8 ... 500 [35 ... 2320]				
Maximum admissible degree of contamination of the hydraulic fluid cleanliness class according to ISO 4406 (c)			Class 20/18/15 ²⁾					

1) As a 3-spool position valve, pressure-centered only possible if $p_{St} \geq 2 \times p_{tank} + p_{St\ min}$.

2) The cleanliness classes specified for the components must be adhered to in hydraulic systems. Effective filtration prevents faults and simultaneously increases the life cycle of the components.

For selecting the filters, see www.boschrexroth.com/filter.

Technical data

(For applications outside these parameters, please consult us!)

hydraulic						
Size	NG	10	16	25 "W.H 22"	25 "W.H 25"	32
Maximum pilot pressure ³⁾	bar [psi]	250 [3626]	250 [3626]	210 [3046]	250 [3626]	250 [3626]
Minimum pilot pressure						
▶ Pilot oil supply X external (all symbols), pilot oil supply X internal (only symbols D, K, E, J, L, M, Q, R, U, W)						
3-spool position valve, spring-centered	Type H-WEH... bar [psi]	12 [174]	14 [203]	12.5 [181]	13 [188]	8.5 [123]
	Type WEH... bar [psi]	12 [174]	14 [203]	10.5 [152]	13 [188]	8.5 [123]
3-spool position valve, pressure-centered	bar [psi]	–	14 [203]	–	18 [261]	8.5 [123]
2-spool position valve with spring end position	Type H-WEH... bar [psi]	10 [145]	14 [203]	14 [203]	13 [188]	10 [145]
	Type WEH... bar [psi]	10 [145]	14 [203]	11 [159]	13 [188]	10 [145]
2-spool position valve with hydraulic end position	bar [psi]	7 [101]	14 [203]	8 [116]	8 [116]	5 [72]
▶ Pilot oil supply X internal (with symbols C, F, G, H, P, T, V, Z, S ⁴⁾)	bar [psi]	7.5 [109] ⁵⁾	4.5 [65] ⁶⁾	4.5 [65] ⁶⁾	4.5 [65] ⁶⁾	4.5 [65] ⁶⁾
Free flow cross-sections in zero position with symbols Q, V and W						
Symbol Q	A – T; B – T mm ² [inch ²]	13 [0.02]	32 [0.05]	78 [0.121]	83 [0.129]	78 [0.121]
Symbol V	P – A; P – B mm ² [inch ²]	13 [0.02]	32 [0.05]	73 [0.113]	83 [0.129]	73 [0.113]
	A – T; B – T mm ² [inch ²]	13 [0.02]	32 [0.05]	84 [0.13]	83 [0.129]	84 [0.13]
Symbol W	A – T; B – T mm ² [inch ²]	2.4 [0.004]	6 [0.009]	10 [0.015]	14 [0.022]	20 [0.031]

- ³⁾ ▶ Pilot oil supply **internal**:
- With a higher pilot pressure, use of a **pressure reducing valve "D3"** is required (if it is not used pilot pressure = operating pressure at the port).
 - In connection with version "H", the **pressure reducing valve "D3"** is also required.
- ▶ **External** pilot oil supply:
- In connection with version "H", compliance with the maximum pilot pressure must be ensured by appropriate measures (e.g. protection of the separate pilot oil circuit by using a pressure relief valve)!
- ⁴⁾ Symbol S only for NG16

- ⁵⁾ For symbols C, F, G, H, P, T, V, Z, an internal pilot oil supply is only possible if the flow from P to T in the central position (for 3-spool position valve) or while crossing the central position (for 2-spool position valve) is so large that the pressure differential of P to T reaches a value of at least 7.5 bar [109 psi] and the pilot oil return Y is implemented externally.
- ⁶⁾ For symbols C, F, G, J, H, P, T, V, Z, S⁴⁾ – by means of preload valve (not NG10) or correspondingly high flow. (Determination of the required flow, see "Preload valve" characteristic curves on page 38.) For NG10, a check valve with a cracking pressure of 7.5 bar [109 psi] is to be provided in the return line to the tank. The pilot oil return Y must be implemented externally.

Technical data

(For applications outside these parameters, please consult us!)

hydraulic						
Size	NG	10	16	25 "W.H 22"	25 "W.H 25"	32
Pilot volume for switching process						
▶ 3-spool position valve, spring-centered	cm ³ [inch ³]	2.04 [0.124]	5.72 [0.349]	7.64 [0.466]	14.2 [0.866]	29.4 [1.794]
▶ 2-spool position valve	cm ³ [inch ³]	4.08 [0.249]	11.45 [0.699]	15.28 [0.932]	28.4 [1.733]	58.8 [3.588]
▶ 3-spool position valve, pressure-centered						
from zero position in switching position "a"	Type WEH cm ³ [inch ³]	-	2.83 [0.173]	-	7.15 [0.436]	14.4 [0.879]
from switching position "a" in zero position	Type WEH cm ³ [inch ³]	-	2.9 [0.177]	-	7.0 [0.427]	15.1 [0.921]
from zero position in switching position "b"	Type WEH cm ³ [inch ³]	-	5.72 [0.349]	-	14.15 [0.863]	29.4 [1.794]
from switching position "b" in zero position	Type WEH cm ³ [inch ³]	-	2.83 [0.173]	-	5.73 [0.349]	14.4 [0.879]
Pilot flow for shortest switching time, approx.	l/min [US gpm]	35 [9.2]	35 [9.2]	35 [9.2]	35 [9.2]	45 [11.9]

Hydraulic fluid	Classification	Suitable sealing materials	Standards	Data sheet
Mineral oils	HL, HLP, HLPD, HVLP, HVLPD	NBR, FKM	DIN 51524	90220
Bio-degradable	▶ Insoluble in water	HETG	ISO 15380	90221
		HEES		
	▶ Soluble in water	HEPG	ISO 15380	
Flame-resistant	▶ Water-free	HFDU (glycol base)	ISO 12922	90222
		HFDU (ester base)		
		HFDR		

**Important information on hydraulic fluids:**

- ▶ For further information and data on the use of other hydraulic fluids, please refer to the data sheets above or contact us.
- ▶ There may be limitations regarding the technical valve data (temperature, pressure range, life cycle, maintenance intervals, etc.).
- ▶ The ignition temperature of the hydraulic fluid used must be 50 K higher than the maximum solenoid surface temperature.

- ▶ **Bio-degradable and flame-resistant:** If these hydraulic fluids are used, small amounts of dissolved zinc may get into the hydraulic system. (700 mg zinc per pole tube).

Switching times

Pilot pressure		bar [psi]	70 [1015]	210 [3046]	250 [3626]	Spring
			ON			OFF
NG10	▶ Without throttle insert	ms	40 ... 60	–	40 ... 60	20 ... 30
	▶ With throttle insert	ms	60 ... 90	–	50 ... 70	20 ... 30
NG16	▶ Without throttle insert	ms	50 ... 80	–	40 ... 60	50 ... 80
	▶ With throttle insert	ms	110 ... 130	–	80 ... 100	50 ... 80
NG25 ("4W.H 22")	▶ Without throttle insert	ms	40 ... 70	40 ... 60	–	50 ... 70
	▶ With throttle insert	ms	140 ... 160	80 ... 110	–	50 ... 70
NG25 ("4W.H 25")	▶ Without throttle insert	ms	70 ... 100	–	50 ... 70	100 ... 130
	▶ With throttle insert	ms	200 ... 250	–	120 ... 150	100 ... 130
NG32	▶ Without throttle insert	ms	80 ... 130	–	70 ... 100	140 ... 160
	▶ With throttle insert	ms	420 ... 560	–	230 ... 350	140 ... 160

Notes:

- ▶ Switching times = Contacting at the pilot control valve until start of opening of the control edge in the main valve and change in the control spool stroke by 95%)
- ▶ The switching times are measured according to ISO 6403 with HLP46, $\vartheta_{oil} = 40 \text{ °C} \pm 5 \text{ °C} [104 \text{ °F} \pm 9 \text{ °F}]$.
With different oil temperatures, variations are possible!
- ▶ The switching times were determined using DC solenoids. They decrease by approx. 20 ms if AC solenoids are used.
- ▶ The shut-off of the solenoids creates voltage peaks, which can be reduced by the use of suitable diodes.
- ▶ The switching times increase by approx. 30 ms if the pressure reducing valve "D3" is used.
- ▶ The switching times have been determined under ideal conditions and may differ in the system, depending on the application conditions.

Characteristic curves: NG10
 (measured with HLP46, $\vartheta_{oil} = 40 \pm 5 \text{ } ^\circ\text{C} [104 \pm 9^\circ\text{F}]$)

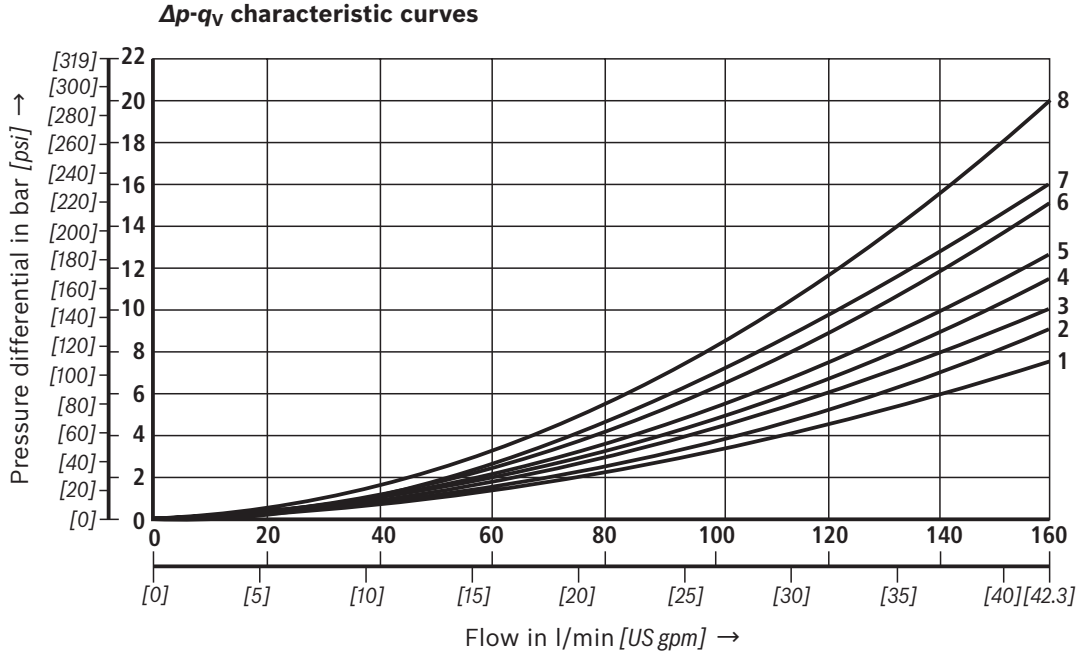

Symbol	Spool position				Zero position		
	P - A	P - B	A - T ¹⁾	B - T ¹⁾	A - T	B - T	P - T
E, Y, D, Q, V, W, Z	1	1	3	5			
F	1	3	1	4	3	-	6
G, T	4	2	4	7	-	-	8
H, C	3	3	1	7	1	5	5
J, K	1	2	1	6			
L	2	2	1	4	2	-	-
M	3	3	2	5			
P	3	1	2	7	-	5	7
R	1	2	3	-			
U	2	2	3	6	-	6	-
A, B	1	1	-	-			

¹⁾ The pressure differential refers to the use of port T. If port T1 is used in addition, the pressure differential may be lower. If only port T1 is used, the relations A - T and B - T may be reversed.

Performance limits: NG10
(measured with HLP46, $\vartheta_{oil} = 40 \pm 5 \text{ °C}$ [$104 \pm 9 \text{ °F}$])

2-spool position valves – $q_{V \max}$ in l/min [US gpm]					
Symbol	Operating pressure p_{\max} in bar [psi]				
	70 [1015]	140 [2030]	210 [3046]	280 [4061]	350 [5076]
X external – spring end position in the main valve ¹⁾ (with $p_{St \min} = 12 \text{ bar}$ [174 psi])					
C, D, K, Y, Z	160 [42]	160 [42]	160 [42]	160 [42]	160 [42]
X external – hydraulic end position in the main valve					
HC, HD, HK, HZ, HY	160 [42]	160 [42]	160 [42]	160 [42]	160 [42]

¹⁾ If the pilot pressure fails, the function of the return spring is no longer guaranteed with the specified flow values!

3-spool position valves – $q_{V \max}$ in l/min [US gpm]					
Symbol	Operating pressure p_{\max} in bar [psi]				
	70 [1015]	140 [2030]	210 [3046]	280 [4061]	350 [5076]
X external – spring-centered					
E, J, L, M, Q, U, V, W, R	160 [42]	160 [42]	160 [42]	160 [42]	160 [42]
F, P	160 [42]	120 [32]	100 [26]	90 [20]	90 [20]
G, T	160 [42]	160 [42]	160 [42]	130 [34]	120 [32]
H	160 [42]	160 [42]	120 [32]	110 [29]	100 [26]



Important information see page 28.

Characteristic curves: NG16
 (measured with HLP46, $\vartheta_{oil} = 40 \pm 5 \text{ } ^\circ\text{C}$ [$104 \pm 9 \text{ } ^\circ\text{F}$])

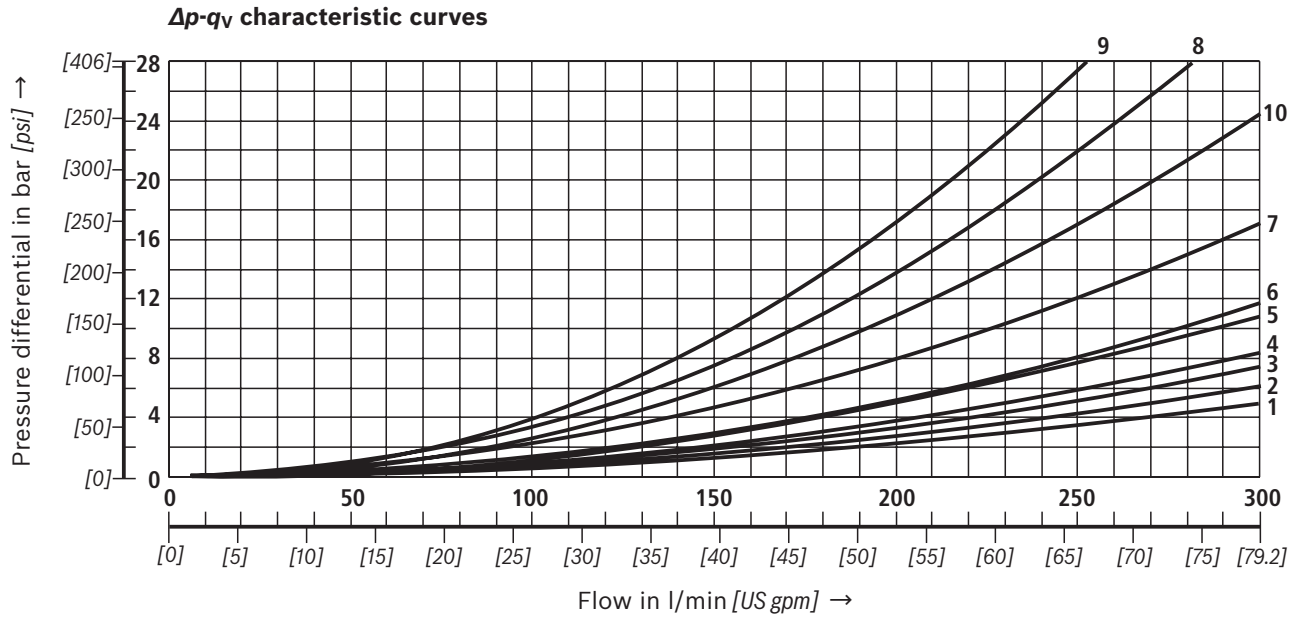

Symbol	Spool position				Zero position		
	P-A	P-B	A-T	B-T	P-T	A-T	B-T
D, E, Y	1	1	3	3			
F	1	2	5	5	4	3	-
G	4	1	5	5	7	-	-
C, H	1	1	5	6	2	4	4
K, J	2	2	6	6	-	3	-
L	2	2	5	4	-	3	-
M	1	1	3	4			
P	2	1	3	6	5	-	-

Symbol	Spool position				Zero position		
	P-A	P-B	A-T	B-T	P-T	A-T	B-T
Q	1	1	6	6			
R	2	4	7	-			
S	3	3	3	-	9	-	-
T	4	1	5	5	7	-	-
U	2	2	3	4			6
V, Z	1	1	6	6	10	8	8
W	1	1	3	4			

Performance limits: NG16(measured with HLP46, $\vartheta_{oil} = 40 \pm 5 \text{ °C}$ [$104 \pm 9 \text{ °F}$])

2-spool position valves – $q_{V \max}$ in l/min [US gpm]					
Symbol	Operating pressure p_{\max} in bar [psi]				
	70 [1015]	140 [2030]	210 [3046]	280 [4061]	350 [5076]
X external – spring end position in the main valve (with $p_{\text{pilot min}} = 12 \text{ bar}$ [174 psi])					
C, D, K, Y, Z	300 [79]	300 [79]	300 [79]	300 [79]	300 [79]
X external – spring end position in the main valve ¹⁾					
C	300 [79]	300 [79]	300 [79]	300 [79]	300 [79]
D, Y	300 [79]	270 [71]	260 [68]	250 [66]	230 [60]
K	300 [79]	250 [66]	240 [63]	230 [60]	210 [55]
Z	300 [79]	260 [68]	190 [50]	180 [47]	160 [42]
X external – hydraulic end position in the main valve					
HC, HD, HK, HZ, HY	300 [79]	300 [79]	300 [79]	300 [79]	300 [79]

¹⁾ If the specified flow values are exceeded, the function of the return spring is no longer guaranteed if the pilot pressure fails!

²⁾ With symbol V, the pilot control valve is not required for flows >160 l/min [42 US gpm].

3-spool position valves – $q_{V \max}$ in l/min [US gpm]					
Symbol	Operating pressure p_{\max} in bar [psi]				
	70 [1015]	140 [2030]	210 [3046]	280 [4061]	350 [5076]
X external – spring-centered					
E, H, J, L, M, Q, U, W, R	300 [79]	300 [79]	300 [79]	300 [79]	300 [79]
F, P	300 [79]	250 [66]	180 [47]	170 [45]	150 [39]
G, T	300 [79]	300 [79]	240 [63]	210 [55]	190 [50]
S	300 [79]	300 [79]	300 [79]	250 [66]	220 [58]
V	300 [79]	250 [66]	210 [55]	200 [53]	180 [47]
X external – pressure-centered (at minimum pilot pressure of 16 bar [232 psi])					
all symbols ²⁾	300 [79]	300 [79]	300 [79]	300 [79]	300 [79]

 **Important information see page 28.**

Characteristic curves: NG25 ("W.H 22")
 (measured with HLP46, $\vartheta_{oil} = 40 \pm 5 \text{ }^\circ\text{C}$ [104 ± 9 °F])

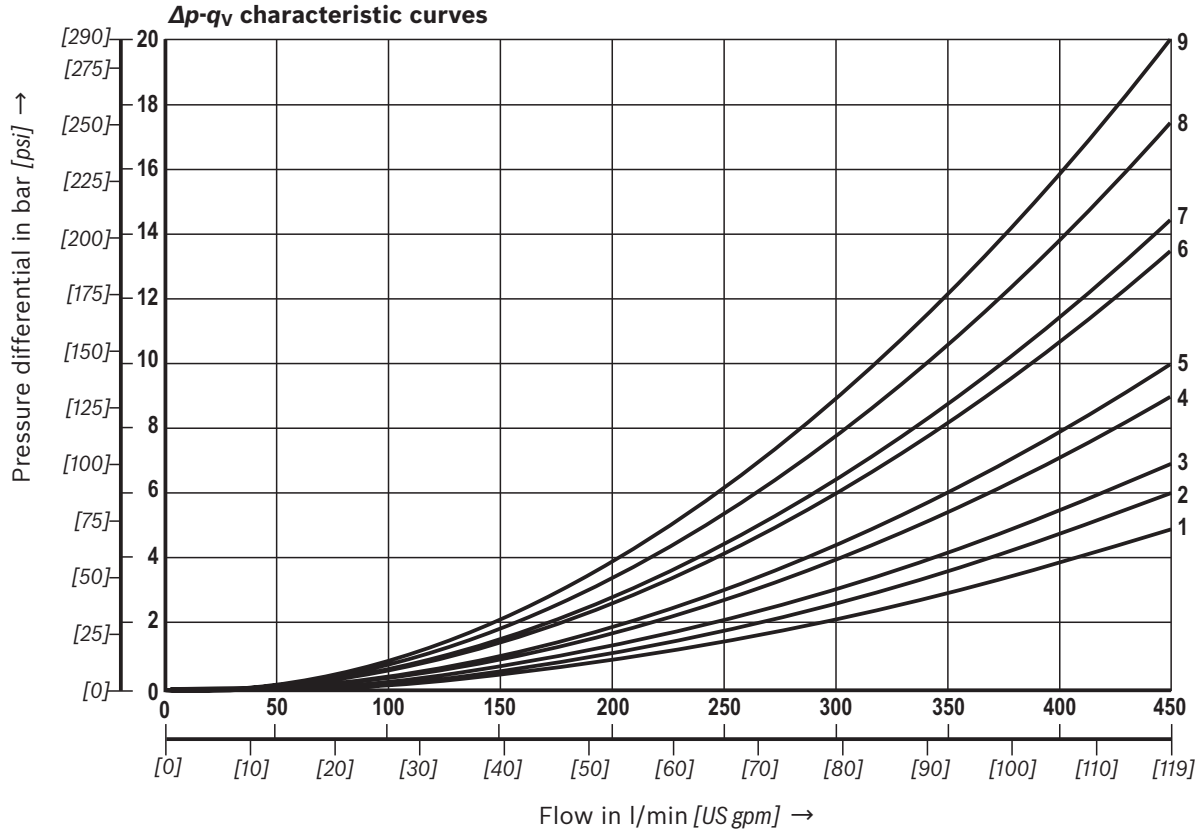

Symbol	Spool position				
	P - A	P - B	A - T	B - T	B - A
E, D	2	2	3	5	-
J, Q, K	2	2	4	6	-
M, W	1	1	3	5	-
H, V, C, Z	1	1	4	6	-
F	1	2	4	5	-
G	3	4	5	6	-
R	1	2	2	-	-
L	2	2	4	5	-
U	2	2	2	6	-
P	2	2	2	7	-
T	4	4	5	6	-

Symbol	Zero position		
	A - T	B - T	P - T
F	2	-	4
G, T	-	-	9
H	-	-	3
L	7	-	-
U	-	6	-
J	8	8	-
P	-	4	6
V, Z	-	-	8

Performance limits: NG25 ("W.H 22")
(measured with HLP46, $\vartheta_{oil} = 40 \pm 5 \text{ }^\circ\text{C}$ [$104 \pm 9 \text{ }^\circ\text{F}$])

2-spool position valves – $q_{V \max}$ in l/min [US gpm]					
Symbol	Operating pressure p_{\max} in bar [psi]				
	70 [1015]	140 [2030]	210 [3046]	280 [4061]	350 [5076]
X external – spring end position in the main valve (with $p_{\text{pilot min}} = 11 \text{ bar} / 14 \text{ bar}$ [159 / 203 psi])					
C, D, K, Y, Z	450 [119]	450 [119]	450 [119]	450 [119]	450 [119]
X external – spring end position in the main valve ¹⁾					
C	450 [119]	450 [119]	320 [84]	250 [66]	200 [53]
D, Y	450 [119]	450 [119]	450 [119]	400 [105]	320 [84]
K	450 [119]	215 [57]	150 [39]	120 [32]	100 [26]
Z	350 [92]	300 [79]	290 [76]	260 [68]	160 [42]
X external – hydraulic end position in the main valve					
HC, HD, HK, HZ, HY	450 [119]	450 [119]	450 [119]	450 [119]	450 [119]
HC./O..., HD./O..., HK./O..., HZ./O...	450 [119]	450 [119]	450 [119]	450 [119]	450 [119]
HC./OF..., HD./ OF..., HK./OF..., HZ./OF...	450 [119]	450 [119]	450 [119]	450 [119]	450 [119]

¹⁾ If the specified flow values are exceeded, the function of the return spring is no longer guaranteed if the pilot pressure fails!

3-spool position valves – $q_{V \max}$ in l/min [US gpm]					
Symbol	Operating pressure p_{\max} in bar [psi]				
	70 [1015]	140 [2030]	210 [3046]	280 [4061]	350 [5076]
X external – spring-centered					
E, J, L, M, Q, U, W, R	450 [119]	450 [119]	450 [119]	450 [119]	450 [119]
H	450 [119]	450 [119]	300 [79]	260 [68]	230 [61]
G	400 [105]	350 [92]	250 [66]	200 [53]	180 [47]
F	450 [119]	270 [71]	175 [46]	130 [34]	110 [29]
V	450 [119]	300 [79]	240 [63]	220 [58]	160 [42]
T	400 [105]	300 [79]	240 [63]	200 [53]	160 [42]
P	450 [119]	270 [71]	180 [47]	170 [45]	110 [29]

 **Important information see page 28.**

Characteristic curves: NG25 ("W.H 25")
 (measured with HLP46, $\vartheta_{oil} = 40 \pm 5 \text{ } ^\circ\text{C}$ [104 \pm 9 $^\circ\text{F}$])

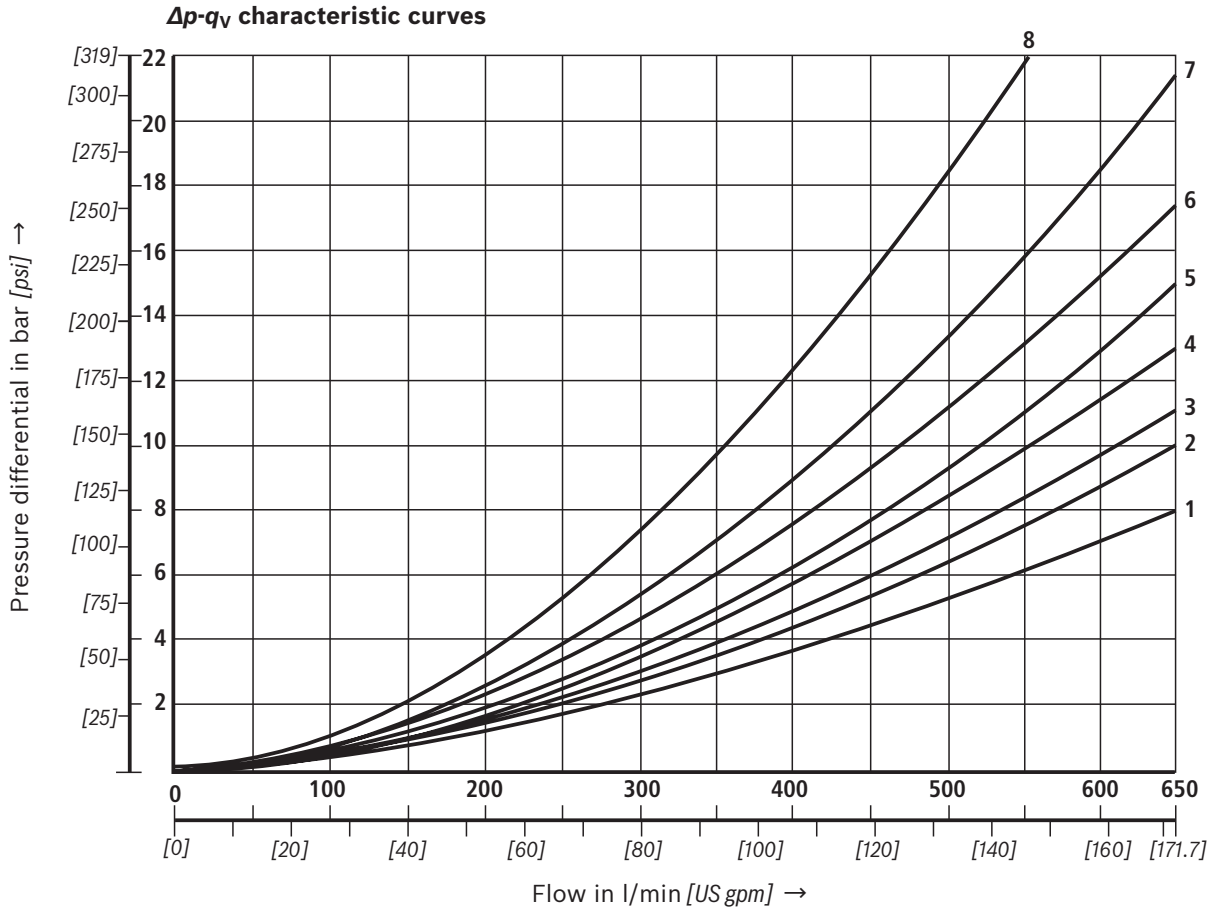

Symbol	Spool position				Zero position		
	P - A	P - B	A - T ¹⁾	B - T ¹⁾	A - T	B - T	P - T
E, Y, D	1	1	3	4			
F	1	1	2	4	2	-	5
G, T	1	1	2	5	-	-	7
H	1	1	2	5	2	2	4
C	1	1	2	5			
J	1	1	2	5	6	5	-
K	1	1	2	5			
L	1	1	2	4	5	-	-
M	1	1	3	4			
P	1	1	3	5	-	3	5
Q	1	1	2	3			
R	1	1	3	-			
U	1	1	2	5	-	5	-
V	1	1	2	5	8	7	-
Z	1	1	2	5			
W	1	1	3	4			

⁸ Symbol R, spool position B - A

Performance limits: NG25 ("W.H 25")
(measured with HLP46, $\vartheta_{oil} = 40 \pm 5 \text{ °C}$ [$104 \pm 9 \text{ °F}$])

2-spool position valves – $q_{V \max}$ in l/min [US gpm]					
Symbol	Operating pressure p_{\max} in bar [psi]				
	70 [1015]	140 [2030]	210 [3046]	280 [4061]	350 [5076]
X external – spring end position in the main valve (with $p_{\text{pilot min}} = 13 \text{ bar}$ [188 psi])					
C, D, K, Y, Z	700 [185]	700 [185]	700 [185]	700 [185]	650 [172]
X external – spring end position in the main valve ¹⁾					
C	700 [185]	700 [185]	700 [185]	700 [185]	650 [172]
D, Y	700 [185]	650 [172]	400 [105]	350 [92]	300 [79]
K	700 [185]	650 [172]	420 [111]	370 [98]	320 [84]
Z	700 [185]	700 [185]	650 [172]	480 [127]	400 [105]
X external – hydraulic end position in the main valve					
HC, HD, HK, HZ, HY	700 [185]	700 [185]	700 [185]	700 [185]	700 [185]
HC./O..., HD./O..., HK./O..., HZ./O...	700 [185]	700 [185]	700 [185]	700 [185]	700 [185]
HC./OF..., HD./OF..., HK./OF..., HZ./OF...	700 [185]	700 [185]	700 [185]	700 [185]	700 [185]

¹⁾ If the specified flow values are exceeded, the function of the return spring is no longer guaranteed if the pilot pressure fails!

3-spool position valves – $q_{V \max}$ in l/min [US gpm]					
Symbol	Operating pressure p_{\max} in bar [psi]				
	70 [1015]	140 [2030]	210 [3046]	280 [4061]	350 [5076]
X external – spring-centered					
E, L, M, Q, U, W	700 [185]	700 [185]	700 [185]	700 [185]	650 [172]
G, T	400 [105]	400 [105]	400 [105]	400 [105]	400 [105]
F	650 [172]	550 [145]	430 [113]	330 [87]	300 [79]
H	700 [185]	650 [172]	550 [145]	400 [105]	360 [95]
J	700 [185]	700 [185]	650 [172]	600 [158]	520 [137]
P	650 [172]	550 [145]	430 [113]	330 [87]	300 [79]
V	650 [172]	550 [145]	400 [105]	350 [92]	310 [82]
R	700 [185]	700 [185]	700 [185]	650 [172]	580 [153]
X external – pressure-centered (at minimum pilot pressure of 18 bar [261 psi])					
E, F, H, J, L, M, P, Q, R, U, V, W	700 [185]	700 [185]	700 [185]	700 [185]	650 [172]
G, T	400 [105]	400 [105]	400 [105]	400 [105]	400 [105]
X external – pressure-centered (with pilot pressure > 30 bar [435 psi])					
G, T	700 [185]	700 [185]	700 [185]	700 [185]	650 [172]

 Important information see page 28.

Characteristic curves: NG32
 (measured with HLP46, $\vartheta_{oil} = 40 \pm 5 \text{ }^\circ\text{C}$ [104 ± 9 °F])

Δp - q_v -characteristic curves – Symbol E, R and W

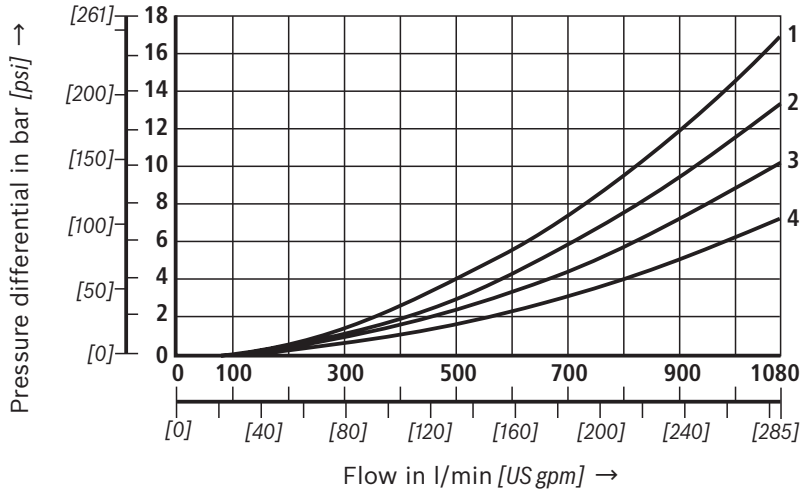

Symbol	Spool position				
	P - A	P - B	A - T	B - T	B - A
E	4	4	3	2	-
R	4	4	3	-	1
W	4	4	3	2	-

Δp - q_v characteristic curves – Symbol G and T

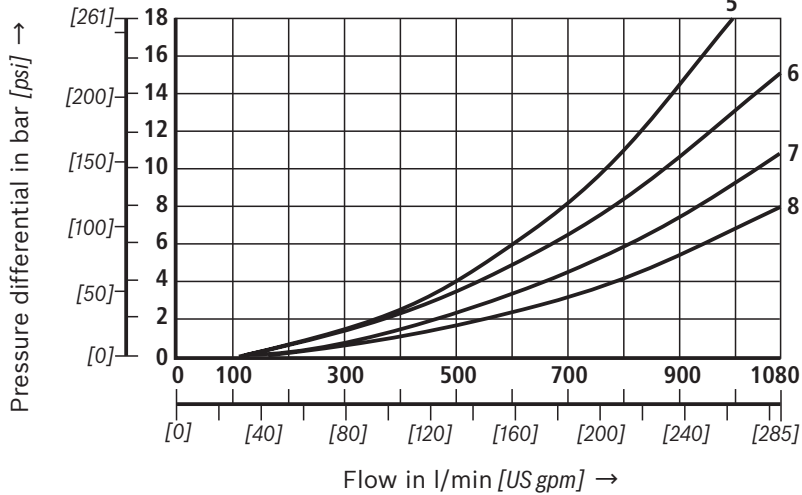

Symbol	Spool position				
	P - A	P - B	A - T	B - T	P - T
G	7	8	7	5	6
T	7	8	7	5	6

Performance limits: NG32(measured with HLP46, $\vartheta_{oil} = 40 \pm 5 \text{ °C}$ [$104 \pm 9 \text{ °F}$])

2-spool position valves – $q_{V \max}$ in l/min [US gpm]					
Symbol	Operating pressure p_{\max} in bar [psi]				
	70 [1015]	140 [2030]	210 [3046]	280 [4061]	350 [5076]
X external – spring end position in the main valve (with $p_{St \min} = 10 \text{ bar}$ [145 psi])					
C, D, K, Y, Z	1100 [290]	1040 [275]	860 [227]	750 [198]	680 [179]
X external – spring end position in the main valve ¹⁾					
C	1100 [290]	1040 [275]	860 [227]	800 [211]	700 [185]
D, Y	1100 [290]	1040 [275]	540 [142]	480 [127]	420 [111]
K	1100 [290]	1040 [275]	860 [227]	500 [132]	450 [119]
Z	1100 [290]	1040 [275]	860 [227]	700 [185]	650 [172]
X external – hydraulic end position in the main valve					
HC, HD, HK, HZ, HY	1100 [290]	1040 [275]	860 [227]	750 [198]	680 [179]

¹⁾ If the specified flow values are exceeded, the function of the return spring is no longer guaranteed if the pilot pressure fails!

3-spool position valves – $q_{V \max}$ in l/min [US gpm]					
Symbol	Operating pressure p_{\max} in bar [psi]				
	70 [1015]	140 [2030]	210 [3046]	280 [4061]	350 [5076]
X external – spring-centered					
E, J, L, M, Q, R, U, W	1100 [290]	1040 [275]	860 [227]	750 [198]	680 [179]
G, T, H, F, P	900 [238]	900 [238]	800 [211]	650 [172]	450 [119]
V	1100 [290]	1000 [264]	680 [179]	500 [132]	450 [119]
X external – pressure-centered (at minimum pilot pressure of 8.5 bar [123 psi])					
all symbols	1100 [290]	1040 [275]	860 [227]	750 [198]	680 [179]

 Important information see page 28.

Performance limits: important information **Notice** (applies to all sizes):

The specified switching power limits apply to the use with two directions of flow (e.g. from P to A and simultaneous return flow from B to T at a ratio of 1:1). Due to the flow forces acting within the valves, the admissible switching power limit may be considerably lower with only one direction of flow (e.g. from P to A

while port B is blocked, with flow in the same or in different directions)!

In such use cases, please consult us!

The switching power limit was established while the solenoids were at operating temperature, at 10% undervoltage, and without tank preloading.

NG16	<ul style="list-style-type: none"> ▶ With pilot oil supply X internal, a preload valve has to be used for flows < 160 l/min [42 US gpm] due to the negative overlap of the symbols C, Z and HC, HZ. ▶ 4/3 directional valves with pressure centering of the control spool in the main valve can be used above the indicated performance limit. In this case, a higher pilot pressure is required (values see performance limits of the corresponding size). ▶ With pilot oil supply X internal, sufficient flow needs to be ensured due to the negative overlap of symbols F, G, H, P, S and T (for determination of the required flow, see "Preload valve" characteristic curves (page 38). If the required flow is not reached, a preload valve has to be used (see page 15).
NG25 ("W.H 22")	<ul style="list-style-type: none"> ▶ With pilot oil supply X internal, a preload valve has to be used for flows < 180 l/min [47.5 US gpm] due to the negative overlap of symbols Z, HZ and V. ▶ With pilot oil supply X internal, sufficient flow needs to be ensured due to the negative overlap of symbols C, HC, F, G, H, P and T (for determination of the required flow, see "Preload valve" characteristic curves (page 38). If the required flow is not reached, a preload valve has to be used (see page 15).
NG25 ("W.H 25")	<ul style="list-style-type: none"> ▶ With pilot oil supply X internal, a preload valve has to be used for flows < 180 l/min [47.5 US gpm] due to the negative overlap of symbols Z, HZ and V. ▶ 4/3 directional valves with pressure centering of the control spool in the main valve can be used above the indicated performance limit. In this case, a higher pilot pressure is required (values see performance limits of the corresponding size). ▶ With pilot oil supply X internal, sufficient flow needs to be ensured due to the negative overlap of symbols C, HC, F, G, H, P and T (for determination of the required flow, see "Preload valve" characteristic curves (page 38). If the required flow is not reached, a preload valve has to be used (see page 15).
NG32	<ul style="list-style-type: none"> ▶ With pilot oil supply X internal, a preload valve has to be used for flows < 180 l/min [47.5 US gpm] due to the negative overlap of symbols Z, HZ and V. ▶ 4/3 directional valves with pressure centering of the control spool in the main valve can be used above the indicated performance limit. In this case, a higher pilot pressure is required (values see performance limits of the corresponding size). ▶ With pilot oil supply X internal, sufficient flow needs to be ensured due to the negative overlap of symbols C, HC, F, G, H, P and T (for determination of the required flow, see "Preload valve" characteristic curves (page 38). If the required flow is not reached, a preload valve has to be used (see page 15).

Dimensions: NG10
(dimensions in mm [inch])

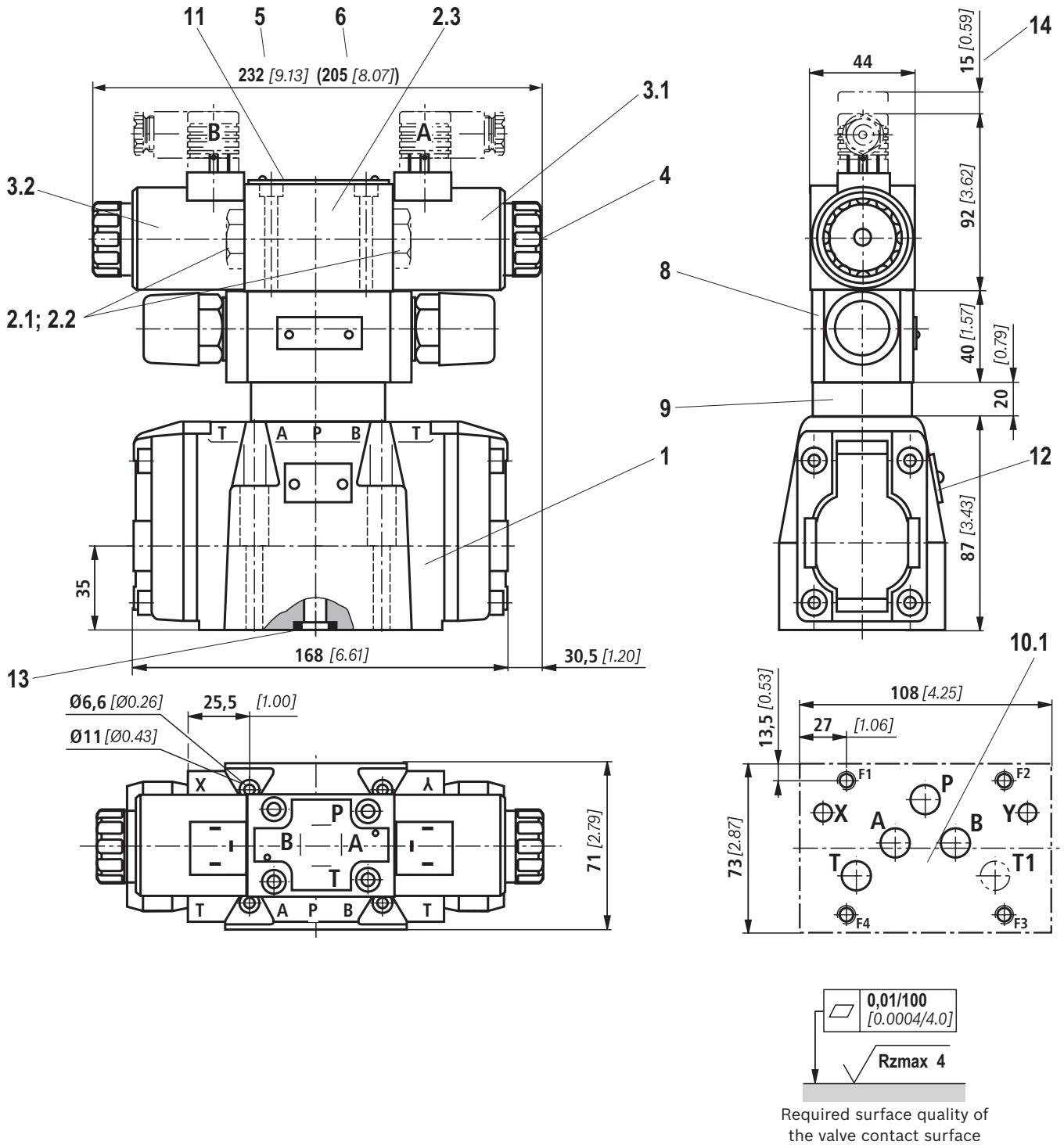

Item explanations, subplates, and valve mounting screws see page 34.

Notice:

The dimensions are nominal dimensions which are subject to tolerances.

Dimensions: NG16
(dimensions in mm [inch])

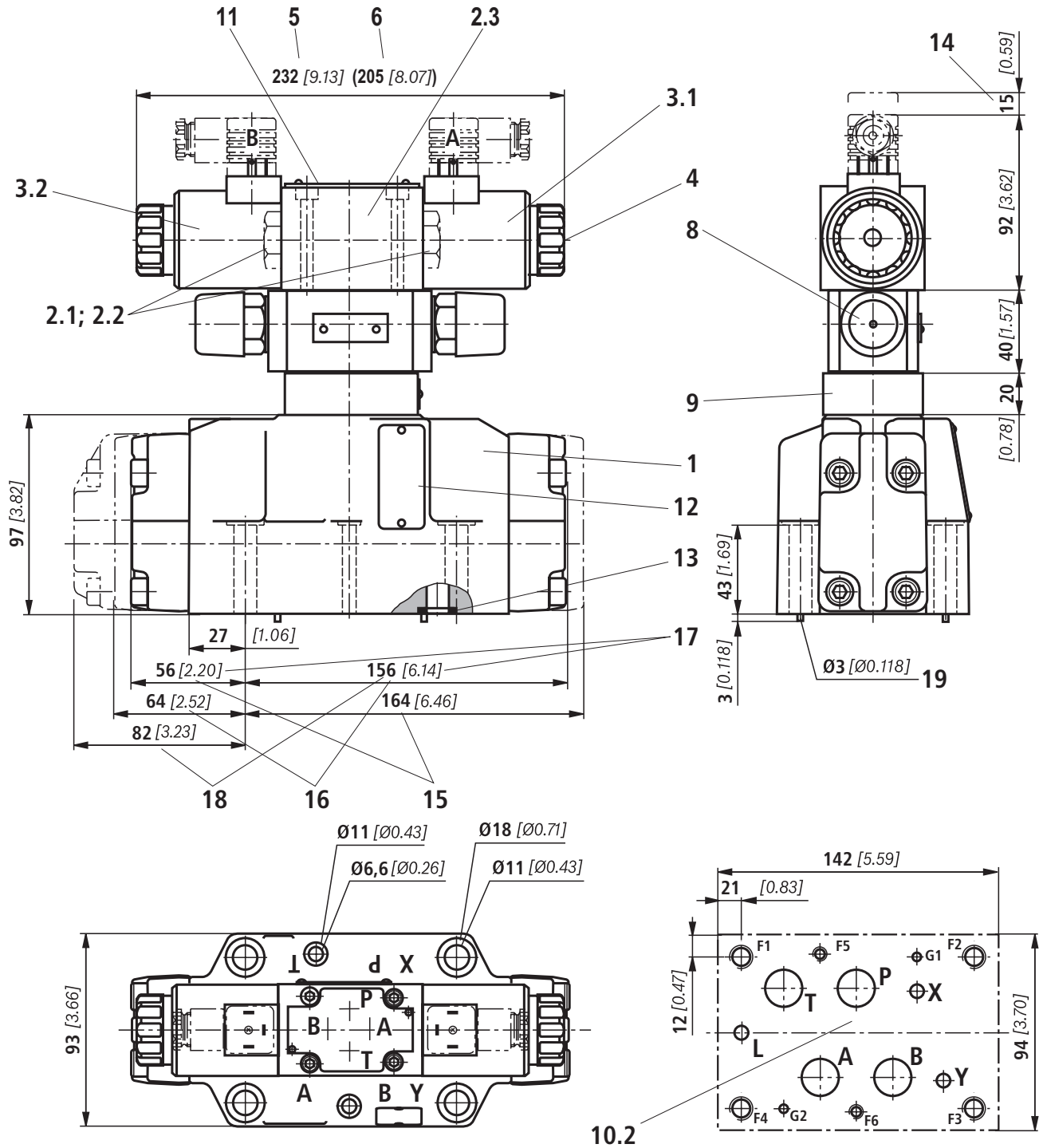

Item explanations, subplates, and valve mounting screws see page 34.



Notice:

The dimensions are nominal dimensions which are subject to tolerances.

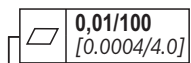

Rzmax 4

Required surface quality of the valve contact surface

Dimensions: NG25 ("W.H 22")
(dimensions in mm [inch])

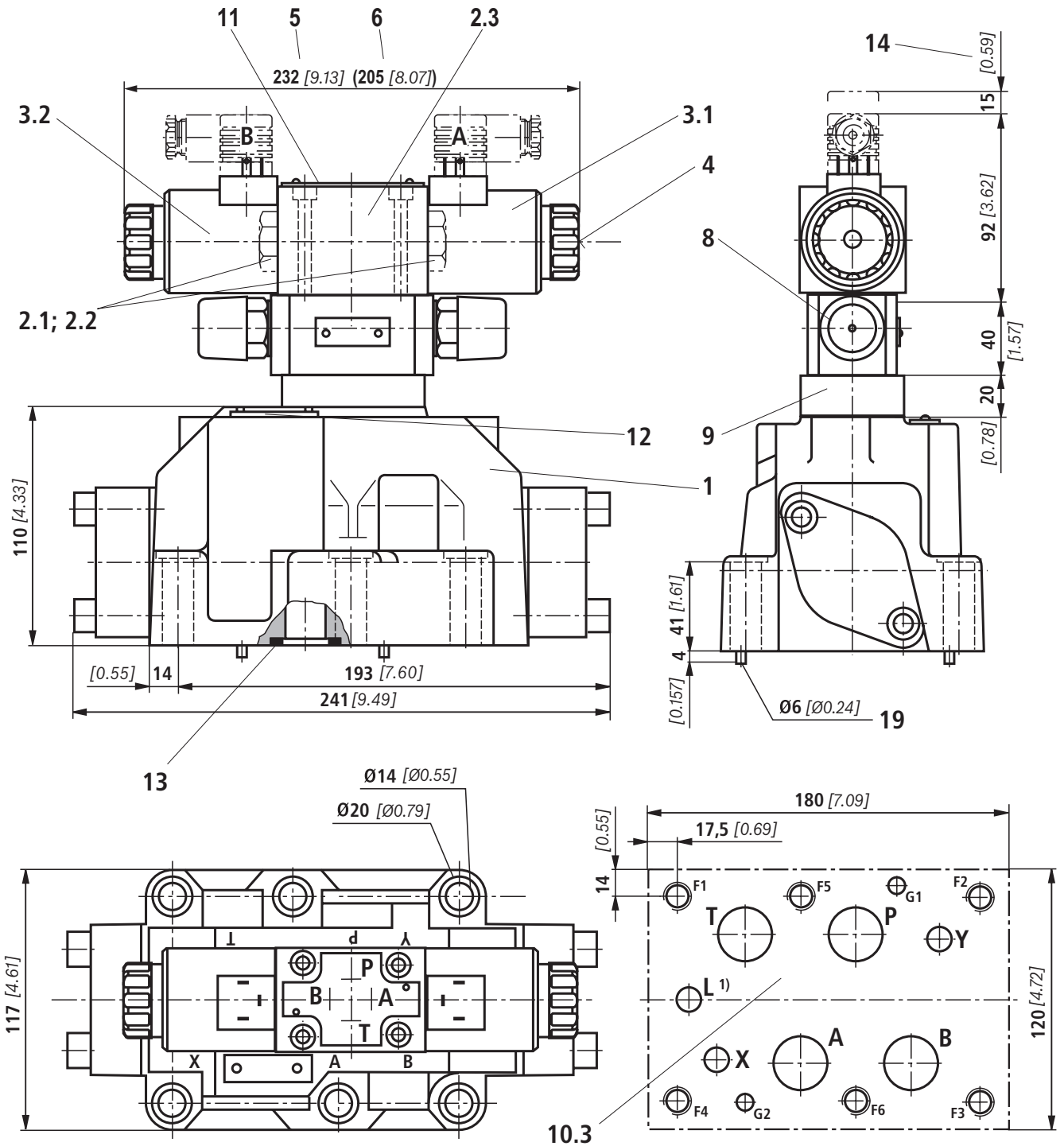

1) Port L only for valves with pressure-centered zero position

Item explanations, subplates, and valve mounting screws see page 34.

Notice:

The dimensions are nominal dimensions which are subject to tolerances.

0,01/100
[0.0004/4.0]

Rzmax 4

Required surface quality of the valve contact surface

Dimensions: NG25 ("W.H 25")
(dimensions in mm [inch])

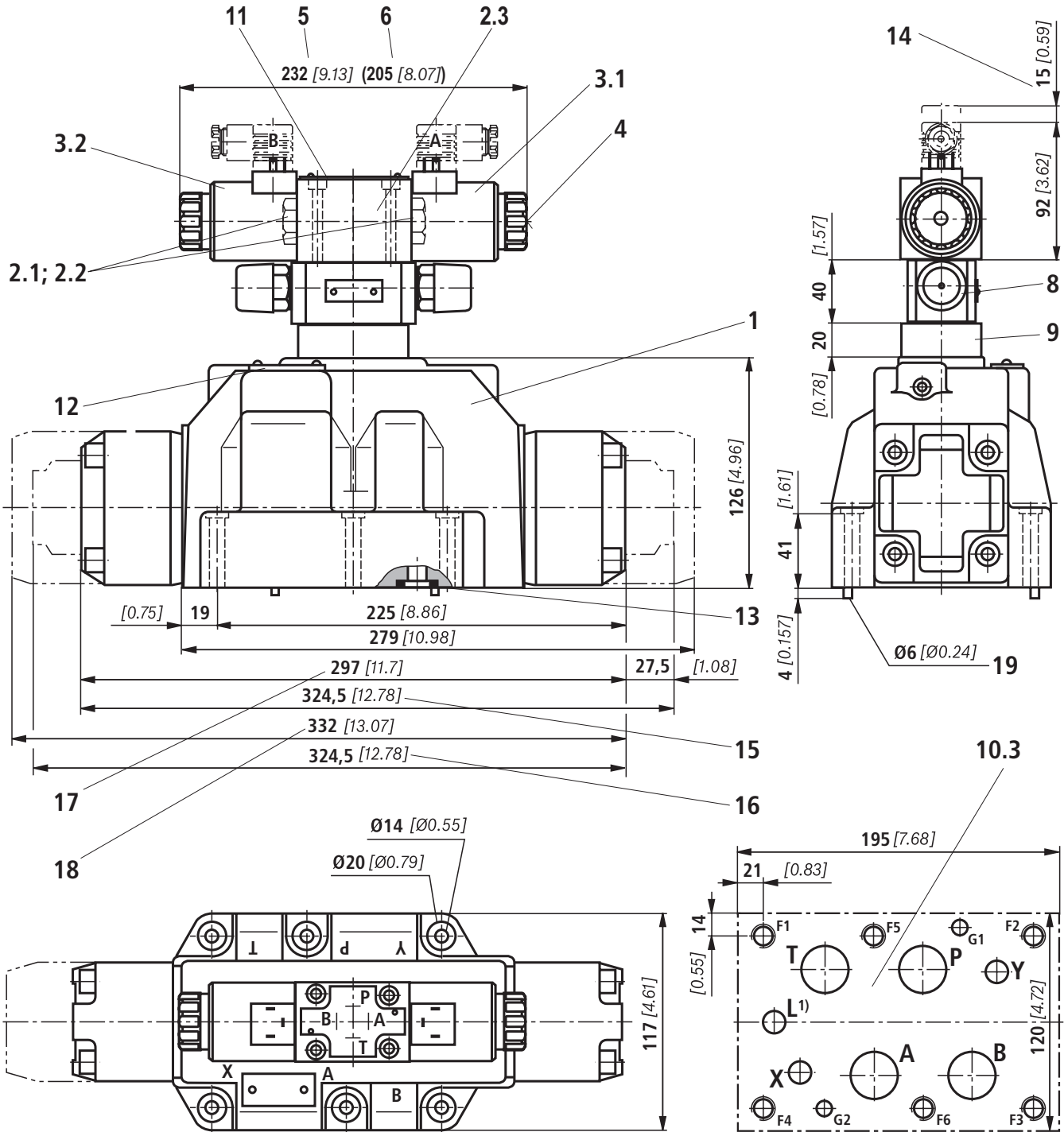

1) Port L only for valves with pressure-centered zero position

Item explanations, subplates, and valve mounting screws see page 34.



Notice:

The dimensions are nominal dimensions which are subject to tolerances.

0,01/100
[0.0004/4.0]

Rzmax 4

Required surface quality of the valve contact surface

Dimensions: NG32
(dimensions in mm [inch])

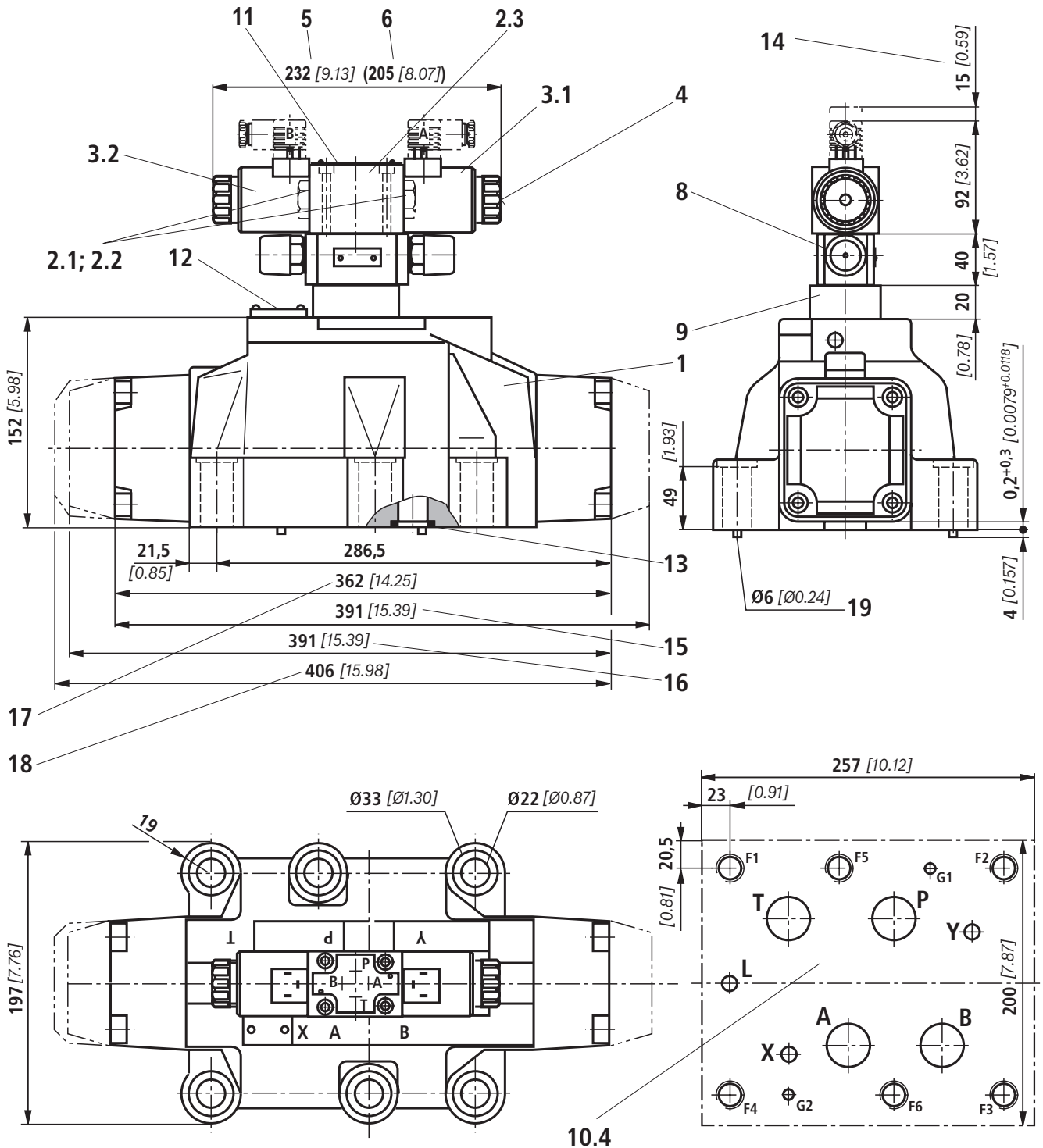

Item explanations, subplates, and valve mounting screws see page 34.

Notice:

The dimensions are nominal dimensions which are subject to tolerances.

0,01/100
[0.0004/4.0]

Rzmax 4

Required surface quality of the valve contact surface

Dimensions

- 1 Main valve
 - 2 Pilot control valve type 4WE 6 ... (data sheet 23208):
 - 2.1 ▶ Pilot control valve type 4WE 6 D... (1 solenoid) for main valves with symbols C, D, K, Z symbols HC, HD, HK, HZ
 - ▶ Pilot control valve type 4WE 6 JA... (1 solenoid "a") for main valves with symbols EA, FA, etc., spring return
 - ▶ Pilot control valve type 4WE 6 MA... (1 solenoid "a") for main valves with symbols HEA, HFA, etc., hydraulic control spool return
 - 2.2 ▶ Pilot control valve type 4WE 6 Y... (1 solenoid) for main valves with symbol Y symbol HY
 - ▶ Pilot control valve type 4WE 6 JB... (1 solenoid "b") for main valves with symbols EB, FB, etc., spring return
 - ▶ Pilot control valve type 4WE 6 MB... (1 solenoid "b") for main valves with symbols HEB, HFB, etc., hydraulic control spool return
 - 2.3 ▶ Pilot control valve type 4WE 6 J... (2 solenoids) for main valves with 3 spool positions, spring-centered
 - ▶ Pilot control valve type 4WE 6 M... (2 solenoids) for main valves with 3 spool positions, pressure-centered
 - 3.1 Solenoid "a"
 - 3.2 Solenoid "b"
 - 4 Concealed manual override "N9"
 - ▶ Actuation of the manual override is only possible up to a tank pressure of approx. 50 bar. Avoid damage to the bore of the manual override! (Special tool for the operation, separate order, material no. **R900024943**). When the manual override is blocked, the operation of the solenoid must be prevented!
 - ▶ Simultaneous actuation of the solenoids must be prevented.
 - 5 Dimension for valve with DC solenoid
 - 6 Dimension () for valve with AC solenoid
 - 8 Switching time adjustment (wrench size 6), optional
 - 9 Pressure reducing valve, optional
 - 10.1 Machined valve contact surface; porting pattern according to ISO 4401-05-05-0-05 and NFPAT3.5.1 R2-D05
 - 10.2 Machined valve contact surface; porting pattern according to ISO 4401-07-07-0-05 and NFPAT3.5.1 R2-D07
 - 10.3 Machined valve contact surface; porting pattern according to ISO 4401-08-08-0-05 and NFPAT3.5.1 R2-D08
 - 10.4 Machined valve contact surface; porting pattern according to ISO 4401-10-09-0-05 and NFPAT3.5.1 R2-D10
 - 11 Name plate pilot control valve
 - 12 Name plate complete valve
 - 13 Seal rings
 - 14 Space required for removing the mating connector
 - 15 2-spool position valves with spring end position in the main valve (symbols A, C, D, K, Z)
 - 16 2-spool position valves with spring end position in the main valve (symbols B, Y)
 - 17 3-spool position valves, spring-centered; 2-spool position valves with hydraulic end position in the main valve
 - 18 3-spool position valves, pressure-centered
 - 19 Locking pin
- Subplates** (separate order) with porting pattern according to ISO 4401 see data sheet 45100.
- Valve mounting screws** (separate order)
- ▶ NG10:
 - 4 hexagon socket head cap screws, metric ISO 4762 - M6 x 45 - 10.9-flZn-240h-L** (friction coefficient $\mu_{\text{total}} = 0.09 \dots 0.14$); tightening torque $M_A = 12.5 \text{ Nm}$ [9.2 ft-lbs] $\pm 10\%$, material no. **R913000258**
 - 4 hexagon socket head cap screws, UNC 1/4-20 UNC x 1 3/4" ASTM-A574** upon request
 - ▶ NG16:
 - 4 hexagon socket head cap screws, metric ISO 4762 - M10 x 60 - 10.9-flZn-240h-L** (friction coefficient $\mu_{\text{total}} = 0.09 \dots 0.14$); tightening torque $M_A = 58 \text{ Nm}$ [42.8 ft-lbs] $\pm 10\%$, material no. **R913000116**
 - 2 hexagon socket head cap screws, metric ISO 4762 - M6 x 60 - 10.9-flZn-240h-L** (friction coefficient $\mu_{\text{total}} = 0.09 \dots 0.14$); tightening torque $M_A = 12.5 \text{ Nm}$ [9.2 ft-lbs] $\pm 10\%$, material no. **R913000115**
 - 4 hexagon socket head cap screws, UNC 3/8-16 UNC x 2 1/4" ASTM-A574** upon request
 - 2 hexagon socket head cap screws, UNC 1/4-20 UNC x 2 1/4" ASTM-A574** upon request
 - ▶ NG25:
 - 6 hexagon socket head cap screws, metric ISO 4762 - M12 x 60 - 10.9-flZn-240h-L** (friction coefficient $\mu_{\text{total}} = 0.09 \dots 0.14$); tightening torque $M_A = 130 \text{ Nm}$ [95.9 ft-lbs] $\pm 10\%$, material no. **R913000121**
 - 6 hexagon socket head cap screws, UNC 1/2-13 UNC x 2 1/2" ASTM-A574** upon request
 - ▶ NG32:
 - 6 hexagon socket head cap screws, metric ISO 4762 - M20 x 80 - 10.9-flZn-240h-L** (friction coefficient $\mu_{\text{total}} = 0.09 \dots 0.14$); tightening torque $M_A = 430 \text{ Nm}$ [317.2 ft-lbs] $\pm 10\%$, material no. **R901035246**
 - 6 hexagon socket head cap screws, UNC 3/4-10 UNC x 3 1/4" ASTM-A574** upon request

Stroke setting, mounting options (dimensions in mm [inch])

The stroke of the control spool is limited by the stroke setting (1). The control spool stroke is shortened by loosening the lock nut (2) and clockwise rotation of the adjustment spindle (3). The control chamber (4) must be depressurized for this.

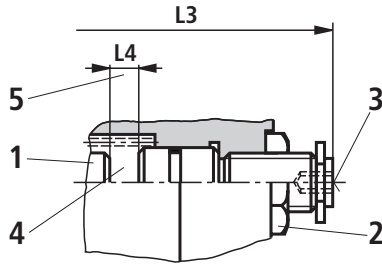

NG	L4
10	6.5 [0.26]
16	10 [0.39]
25 ("W.H 22")	9.5 [0.37]
25 ("W.H 25")	12.5 [0.49]
32	15 [0.59]

More dimensions see below and page 36.

5 Adjustment range

- ▶ NG10:
1 rotation = 1 mm [0.0394 inch] adjustment travel
- ▶ NG16 and 32:
1 rotation = 1.5 mm [0.0591 inch] adjustment travel

Stroke limitation on side A

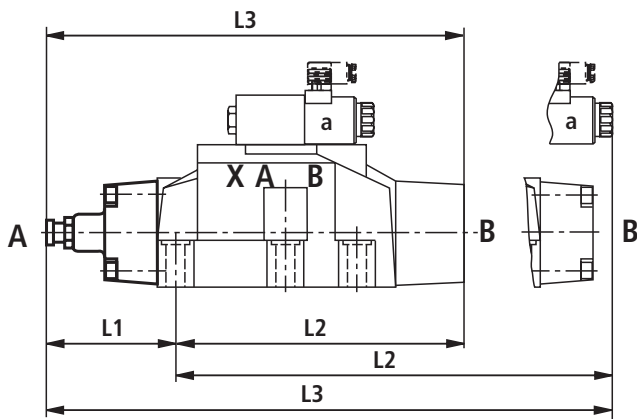

Stroke limitation on side B

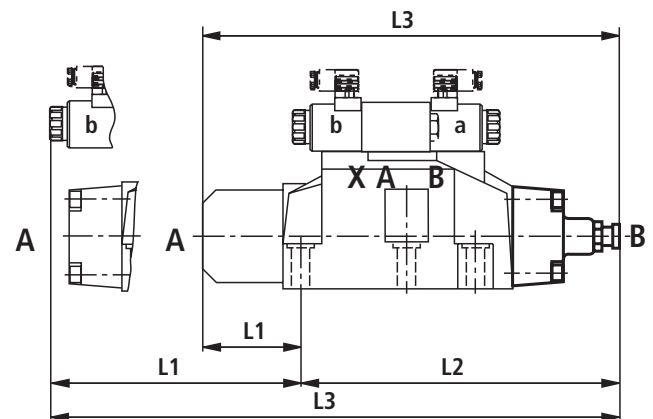

Mounting options	Ordering code	NG	3-spool position valve ¹⁾					
			spring-centered			pressure-centered		
			L1	L2	L3	L1	L2	L3
Stroke setting on valve side A and B	10	10	90 [3.54]	144 [5.67]	234 [9.21]			
		16	100 [3.94]	200 [7.87]	300 [11.81]			
		25 ²⁾	96 [3.77]	241 [9.49]	337 [13.27]			
		25 ³⁾	123 [4.84]	276 [10.87]	399 [15.71]			
		32	133 [5.24]	344 [13.54]	477 [18.78]			
Stroke setting on valve side A	11	10	90 [3.54]	106 [4.17]	196 [7.72]			
		16	100 [3.94]	156 [6.14]	256 [10.08]			
		25 ²⁾	96 [3.77]	193 [7.60]	289 [11.38]			
		25 ³⁾	123 [4.84]	225 [8.86]	348 [13.70]			
		32	133 [5.24]	287 [11.30]	420 [16.54]			
Stroke setting on valve side B	12	10	52 [2.05]	144 [5.67]	196 [7.72]	-	-	-
		16	56 [2.20]	200 [7.87]	256 [10.08]	81 [3.19]	200 [7.87]	281 [11.06]
		25 ²⁾	48 [1.89]	241 [9.49]	289 [11.38]	-	-	-
		25 ³⁾	72 [2.83]	276 [10.87]	348 [13.70]	107 [4.21]	276 [10.87]	283 [11.14]
		32	76 [2.99]	344 [13.54]	420 [16.54]	120 [4.72]	344 [13.54]	464 [18.27]

Stroke setting, mounting options (dimensions in mm [inch])

Mounting options	Ordering code	NG	2-spool position valve								
			Spring end position						Hydraulic end position		
			A, C, D, K, Z			B, Y			HC, HD, HK, HZ, HY		
			L1	L2	L3	L1	L2	L3	L1	L2	L3
Stroke setting on valve side A and B	10	10	90 [3.54]	144 [5.67]	234 [9.21]	90 [3.54]	144 [5.67]	234 [9.21]	90 [3.54]	144 [5.67]	234 [9.21]
		16	-	-	-	-	-	-	100 [3.94]	200 [7.87]	300 [11.81]
		25 ²⁾	96 [3.78]	241 [9.49]	337 [13.27]	96 [3.78]	241 [9.49]	337 [13.27]	96 [3.78]	241 [9.49]	337 [13.27]
		25 ³⁾	-	-	-	-	-	-	123 [4.84]	276 [10.87]	399 [15.71]
		32	-	-	-	-	-	-	133 [5.24]	344 [13.54]	477 [18.78]
Stroke setting on valve side A	11	10	90 [3.54]	106 [4.17]	196 [7.72]	-	-	-	90 [3.54]	106 [4.17]	196 [7.72]
		16	100 [3.94]	180 [7.09]	280 [11.02]	-	-	-	100 [3.94]	156 [6.14]	256 [10.08]
		25 ²⁾	96 [3.78]	193 [7.60]	289 [11.38]	96 [3.78]	193 [7.60]	289 [11.38]	96 [3.78]	193 [7.60]	289 [11.38]
		25 ³⁾	123 [4.84]	253 [9.96]	376 [14.8]	-	-	-	123 [4.84]	225 [8.86]	348 [13.70]
		32	133 [5.24]	316 [12.44]	449 [17.68]	-	-	-	133 [5.24]	287 [11.30]	420 [16.53]
Stroke setting on valve side B	12	10	52 [2.05]	144 [5.67]	196 [7.72]	52 [2.05]	144 [5.67]	196 [7.72]	52 [2.05]	144 [5.67]	196 [7.72]
		16	-	-	-	80 [3.15]	200 [7.87]	280 [11.02]	56 [2.21]	200 [7.87]	256 [10.08]
		25 ²⁾	48 [1.89]	241 [9.49]	289 [11.38]	48 [1.89]	241 [9.49]	289 [11.38]	48 [1.89]	241 [9.49]	289 [11.38]
		25 ³⁾	-	-	-	100 [3.94]	276 [10.87]	376 [14.80]	72 [2.84]	276 [10.87]	348 [13.70]
		32	-	-	-	105 [4.13]	344 [13.54]	449 [17.68]	76 [2.99]	344 [13.54]	420 [16.53]

1) With symbol A only version "11", with symbol B only version "12" possible.

2) Version "W.H 22"

3) Version "W.H 25"

 **Notice:**

The dimensions are nominal dimensions which are subject to tolerances.

Switching time adjustment

The switching time of the main valve (1) is influenced by using a twin throttle check valve (2) (type Z2FS 6; data sheet 27506).

Modification of supply (3) to discharge control (4):

Remove the pilot control valve (5) – The plate (6) to accept the seal rings stays in place – Turn the switching time adjustment (2) around its longitudinal axis and put it back, install the pilot control valve (5).

Notice:

The modification may only be performed by authorized specialists or at the factory!

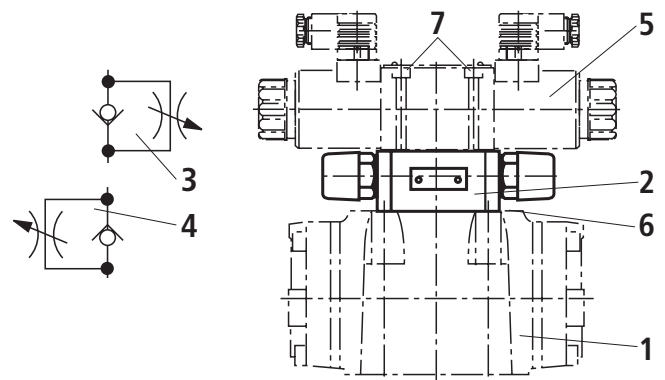

Type .WEH 10 ..4X/...S
Type .WEH 10 ..4X/...S2

Pressure reducing valve "D3"

The pressure reducing valve (8) has to be used at a pilot pressure above 250 bar [3626 psi] (with "WEH 22 ...": 210 bar [3046 psi]) and with version "H".

The secondary pressure is kept at a constant level of 45 bar [652 psi].

Notice:

- ▶ If a pressure reducing valve "D3" (8) is used, a "B10" throttle insert has to be installed in channel P of the pilot control valve.
- ▶ The modification may only be performed by authorized specialists or at the factory!

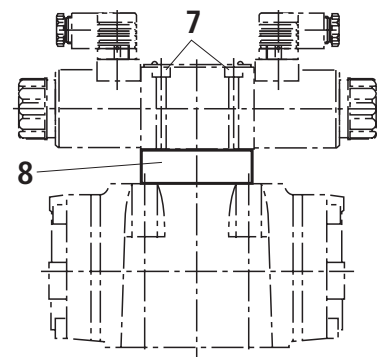

Type .WEH 10 ..4X/.../..D3

Preload valve (not for NG10)

In case of valves with depressurized circulation and internal pilot oil supply, the installation of the preload valve (9) in channel P of the main valve is required in order to build up the minimum pilot pressure.

The pressure differential of the preload valve is to be added to the pressure differential of the main valve (see characteristic curves) to result in one total value. The cracking pressure amounts to approx. 4.5 bar [65 psi].

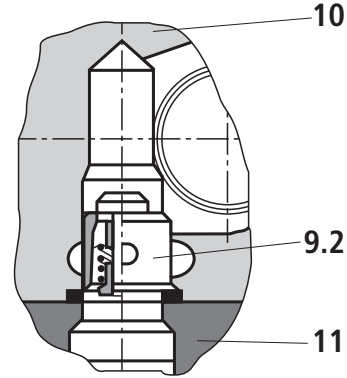
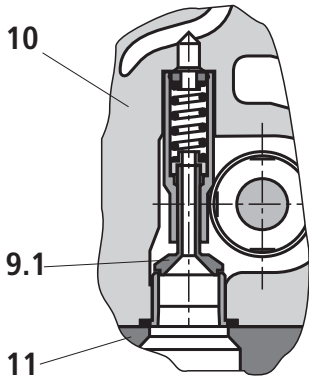

- 9.1 Preload valve
- 9.2 Preload valve
- 10 Main valve
- 11 Subplate

Notice:
Series-production status, see ordering key on the name plate.

Size	Material number P4,5	
	Item 9.2	Item 9.1
16	R961009417 (up to component series 71)	R961009415 (from component series 72)
25 ("W.H 22")	R961009609 (up to component series 76)	-
25 ("W.H 25")	R961009416 (up to component series 67)	R961009166 (from component series 68)
32	R961009610 (up to component series 63)	-

Δp - q_v -characteristic curve (measured with HLP46, $\vartheta_{oil} = 40\text{ °C} \pm 5\text{ °C}$ [104 °F \pm 9 °F])

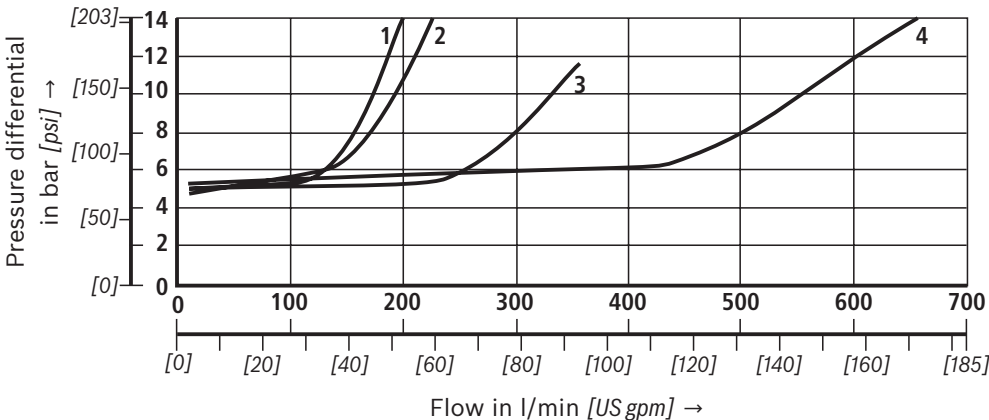

- 1 NG16
- 2 NG25 ("W.H 25")
- 3 NG25 ("W.H 22")
- 4 NG32

Project planning information

The stipulations of the Machinery Directive 2006/42/EC are to be adhered to!

Please also note data sheet 08012 with information on MTTFd values and shock and vibration loads!

Further information

- | | |
|---|--|
| ▶ Directional spool valve (solenoid coil with UR-marking according to UL 906) | Data sheet 23208 |
| ▶ Subplates | Data sheet 45100 |
| ▶ Inductive position switch and proximity sensors (contactless) | Data sheet 24830 |
| ▶ Hydraulic fluids on mineral oil basis | Data sheet 90220 |
| ▶ Environmentally compatible hydraulic fluids | Data sheet 90221 |
| ▶ Flame-resistant, water-free hydraulic fluids | Data sheet 90222 |
| ▶ Hexagon socket head cap screw, metric/UNC | Data sheet 08936 |
| ▶ Hydraulic valves for industrial applications | Operating instructions 07600-B |
| ▶ Directional spool valves and directional seat valves with electrical actuation and M12x1 plug-in connection | Data sheet 08010 |
| ▶ Use of non-electrical hydraulic components in an explosive environment (ATEX) | Data sheet 07011 |
| ▶ Selection of the filters | www.boschrexroth.com/filter |
| ▶ Information on available spare parts | www.boschrexroth.com/spc |

Notes

Bosch Rexroth AG
Hydraulics
Zum Eisengießer 1
97816 Lohr am Main, Germany
Phone +49 (0) 93 52/18-0
documentation@boschrexroth.de
www.boschrexroth.de

© This document, as well as the data, specifications and other information set forth in it, are the exclusive property of Bosch Rexroth AG. It may not be reproduced or given to third parties without its consent.
The data specified above only serve to describe the product. No statements concerning a certain condition or suitability for a certain application can be derived from our information. The information given does not release the user from the obligation of own judgment and verification. It must be remembered that our products are subject to a natural process of wear and aging.