

Proportional controls for PVPC pumps

analog pressure or flow, digital P/Q controls

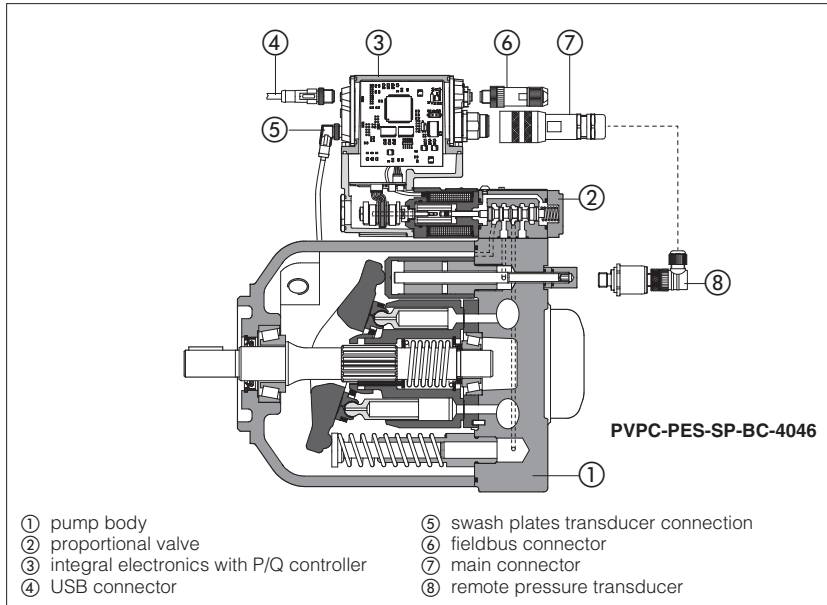

The variable displacement axial piston pumps type PVPC, can be supplied with advanced electrohydraulic proportional controls:

- open loop pressure control;
- open loop flow control (load sensing);
- closed loop P/Q control;

They allow to perform high dynamics and fine regulations, directly commanded from PLC or from the machine controller.

New PES digital controllers, integrated to the pump, performs alternate closed loop controls of pressure, flow and max power limitation. It is also available with optional sequence module (PERS versions) that allows to reduce close to zero the pressure to the delivery line.

SAE J744 mounting flange and shaft.

Max displacement: **29, 46, 73, 88 cm³/rev**

Max pressure: **280 bar working**

350 bar peak

For technical characteristics and features, see tech table A160.

1 MODEL CODE

PVPC	X2E	PERS - SP	BC	4	046	/ *	/ *	/ 1	D	/ *	10	/ *
<p>Variable displacement axial piston pump</p> <p>Additional suffix for double pumps X2E = with a fixed displacement pump type PFE (see tech table A005)</p> <p>Type of control (see section 7 and 8): CZ = proportional pressure control LQZ = prop. flow control (load sensing) PES-SP = closed loop integral digital P/Q driver PERS-SP = as PES plus sequence module</p> <p>Fieldbus interfaces for PES and PERS: USB interface always present NP = Not present BC = CANopen EH = EtherCAT BP = PROFIBUS DP EI = EtherNet/IP EW = POWERLINK EP = PROFINET IRT</p> <p>Size: 3 = for displacement 029 4 = for displacement 046 5 = for displacement 073 and 090</p> <p>Max displacement: 029 = 29 cm³/rev 046 = 46 cm³/rev 073 = 73 cm³/rev 090 = 88 cm³/rev</p> <p>Type of PFE (for double pumps), see tech table A005</p> <p>Pressure setting (only for PERS): 200 = 200 bar 250 = 250 bar 280 = 280 bar</p>	<div style="border: 1px solid black; padding: 5px; margin-bottom: 10px;"> Seals material: - = NBR PE = FKM </div> <p style="margin-left: 20px;">Series number</p> <p>Options, for CZ, LQZ see sections 4: 18 = optional coil for low current drivers</p> <p>Electronics options for PES and PERS see section 11: C = current feedback for pressure transducer 4÷20 mA I = current reference input and monitor 4÷20 mA (omit for standard voltage reference input and monitor ±10 V) X = with integral pressure transducer (only for PERS) S = with two on-off inputs for multiple pressure PID selection (NP execution) or double power supply (BC, BP, EH, EW and EP execution).</p> <p>Direction of rotation (viewed at the shaft end) D = clockwise S = counterclockwise</p> <p>Shaft (SAE Standard): 1 = keyed (7/8" for 029 - 1" for 046 1 1/4" for 073 and 090) 5 = splined (13 teeth for 029 - 15 for 046 14 for 073 and 090)</p>											

2 OPERATING CHARACTERISTICS

Pump model		PVPC-*-3029		PVPC-*-4046		PVPC-*-5073		PVPC-*-5090	
		Type1 200	Type5 190	Type1 230	Type5 330	Type1 490	Type5 620	Type1 490	Type5 620
Displacement	[cm ³ /rev]	29		46		73		88	
Theoretical max flow at 1450 rpm	[l/min]	42		66,7		105,8		127,6	
Max working pressure / Peak pressure	[bar]	280/350		280/350		280/350		250/315	
Min/Max inlet pressure	[bar abs.]	0,8 / 25		0,8 / 25		0,8 / 25		0,8 / 25	
Max pressure on drain port	[bar abs.]	1,5		1,5		1,5		1,5	
Power consumption at 1450 rpm and at maximum pressure and displacement	[kW]	19,9		31,6		50,1		54,1	
Max torque on the first shaft	[Nm]	1000		1500		2000		2000	
Max permissible load on drive shaft	[N]	1500		1500		3000		3000	
Speed rating	[rpm]	500 ÷ 3000		500 ÷ 2600		500 ÷ 2600		500 ÷ 2200	

External load position

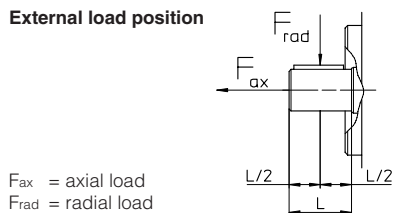

F_{ax} = axial load
 F_{rad} = radial load

Notes: For speeds over 1800 rpm the inlet port must be under oil level with adequate pipes.
Maximum pressure for all models with water glycol fluid is 160 bar, with /PE options is 190 bar.
Max speed with /PE options and water glycol fluid is 2000/1900/1600/1500 rpm respectively for the four sizes.

3 GENERAL NOTES

Atos proportional pumps are CE marked according to the applicable Directives (e.g. Immunity/Emission EMC Directive and Low Voltage Directive).

Installation, wirings and start-up procedures must be performed according to the general prescriptions shown in table F003 and in the installation notes supplied with relevant components.

The electrical signals of the pump (e.g. monitor signals) must not be directly used to activate safety functions, like to switch-ON/OFF the machine's safety components, as prescribed by the European standards (Safety requirements of fluid technology systems and components-hydraulics, EN-982).

4 MAIN CHARACTERISTICS - based on mineral oil ISO VG 46 at 50 °C

Assembly position	Any position. The drain port must be on the top of the pump. Drain line must be separated and unrestricted to the reservoir and extended below the oil level as far from the inlet as possible. Suggested maximum line length is 3 m.				
Subplate surface finishing	Roughness index, Ra 0,4 flatness ratio 0,01/100 (ISO 1101)				
Ambient temperature range	-CZ, -LQZ execution = -20°C ÷ +70°C -PES and -PERS executions = -20°C ÷ +60°C				
Storage temperature range	-20°C ÷ +70°C				
Coil resistance R at 20°C	<table border="0"> <tr> <td style="padding-right: 10px;">pump size 3</td> <td>3 ÷ 3,3 Ω for standard 12 Vdc coil; 13 ÷ 13,4 Ω for 18 Vdc coil (only for version CZ, LQZ)</td> </tr> <tr> <td>pump size 4, 5</td> <td>3,8 ÷ 4,1 Ω for standard 12 Vdc coil; 12 ÷ 12,5 Ω for 18 Vdc coil (only for version CZ, LQZ)</td> </tr> </table>	pump size 3	3 ÷ 3,3 Ω for standard 12 Vdc coil; 13 ÷ 13,4 Ω for 18 Vdc coil (only for version CZ, LQZ)	pump size 4, 5	3,8 ÷ 4,1 Ω for standard 12 Vdc coil; 12 ÷ 12,5 Ω for 18 Vdc coil (only for version CZ, LQZ)
pump size 3	3 ÷ 3,3 Ω for standard 12 Vdc coil; 13 ÷ 13,4 Ω for 18 Vdc coil (only for version CZ, LQZ)				
pump size 4, 5	3,8 ÷ 4,1 Ω for standard 12 Vdc coil; 12 ÷ 12,5 Ω for 18 Vdc coil (only for version CZ, LQZ)				
Max. solenoid current	2,6 A for standard 12 Vdc coil; 1,5 A for standard 18 Vdc coil (only for version CZ, LQZ)				
Max. power	CZ, LQZ execution = 35 Watt; PES, PERS executions = 50 Watt				
Power supply for pressure transducer (PE*S)	24 Vdc				
Insulation class	H (180°) Due to the occurring surface temperatures of the solenoid coils, the European standards ISO 13732-1 and EN982 must be taken into account				
Protection degree to DIN EN60529	CZ, LQZ executions = IP65 PES, PERS executions = IP66/67 with mating connector				
Duty factor	Continuous rating (ED=100%)				
EMC, climate and mechanical load	See technical table G004				

5 SEALS AND HYDRAULIC FLUID - for other fluids not included in above table, consult our technical office

Seals, recommended temperature fluid	NBR seals = -20°C ÷ +60°C, with HFC hydraulic fluids = -20°C ÷ +50°C FKM seals = -20°C ÷ +80°C		
Recommended viscosity	20÷100 mm ² /s - max allowed range 15 ÷ 380 mm ² /s - max start-up viscosity 1000 mm ² /s		
Fluid contamination class	ISO 4406 class 20/18/15 NAS 1638 class 9, in line filters of 10 μm (β10 ≥75 recommended)		
Hydraulic fluid	Suitable seals type	Classification	Ref. Standard
Mineral oils	NBR, FKM	HL, HLP, HLPD, HVLP, HVLPD	DIN 51524
Flame resistant without water	FKM	HFDU, HFDR	ISO 12922
Flame resistant with water	NBR	HFC	

Note: for other fluids not included in above table, consult our technical office

6 ELECTRONIC DRIVERS

Pump model	CZ, LQZ						PES, PERS
Drivers model	E-MI-AC-01F	E-BM-AC	E-ME-AC	E-MI-AS-IR	E-BM-AS-PS	E-BM-AES	E-RI-PES
Type	Analog			Digital			
Format	plug-in to solenoid	DIN 43700 UNDECAL	EUROCARD	plug-in to solenoid	DIN-rail panel		Integral to valve
Data sheet	G010	G025	G035	G020	G030	GS050	GS215

Note: for power supply and communication connector see table GS215

7 OPEN LOOP ELECTROHYDRAULIC CONTROLS

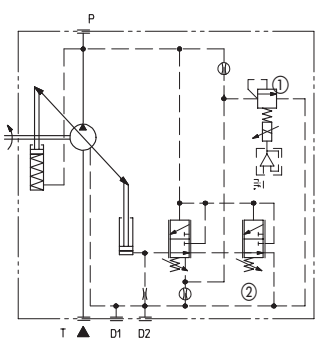

CZ Proportional pressure control

Open loop control of the pump max pressure. The pump's displacement, and thus the flow, remains constant as far as the pressure in the circuit reaches the value set on the proportional pilot valve (1), then the flow is reduced to maintain the circuit pressure to the value set by the electronic reference signal to the proportional valve. In this condition the pressure in the circuit can be continuously modulated by means of the reference signal. Proportional pressure setting range: see below pressure control diagram. Compensator setting range (2): 20÷350 bar (315 bar for 090). Compensator factory setting (2): 280 bar (250 bar for 090).

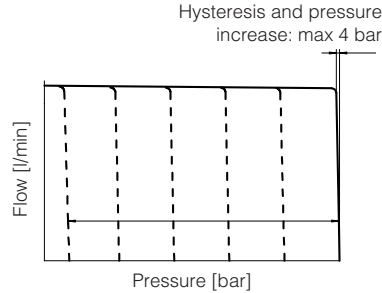

Hysteresis and pressure increase: max 4 bar

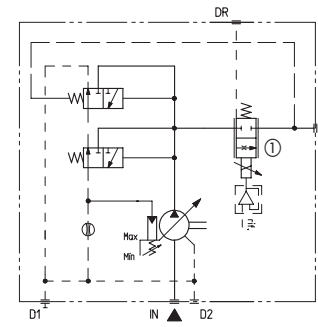

LQZ Proportional flow (load-sensing)

Open loop control of the pump flow independent to the circuit load. The pump displacement is self-adjusted to maintain a constant pressure drop across the proportional flow control valve (1). The pump flow can be continuously regulated by modulating the proportional valve (1).

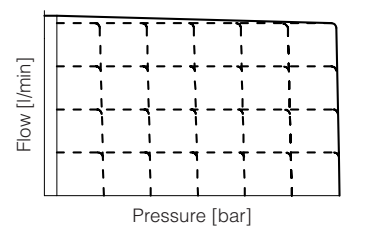

Diagrams for CZ, LQZ

Regulation diagrams

1 = Flow control
2 = Pressure control

(1) for standard 12 Vdc coil
(2) for 18 Vdc coil

Pump size
88 73 46 29 cm³/rev

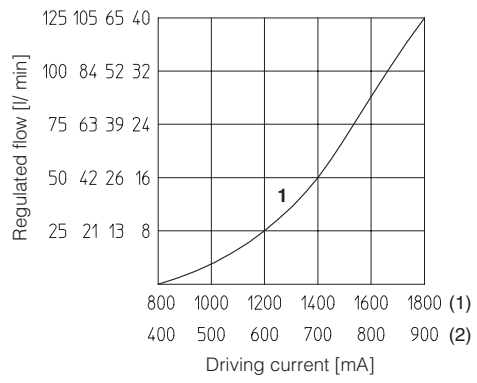

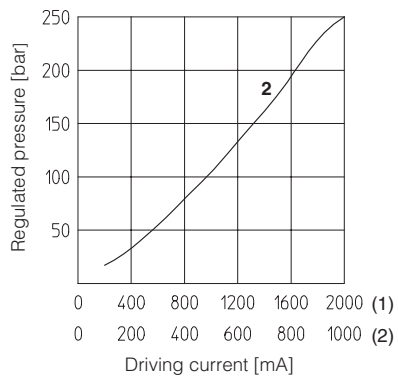

8 CONNECTIONS FOR CZ AND LQZ

SOLENOID POWER SUPPLY CONNECTOR	
PIN	Signal description
1	SUPPLY
2	SUPPLY
3	GND

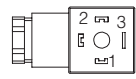

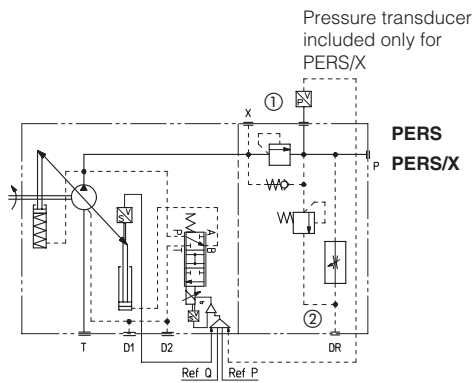
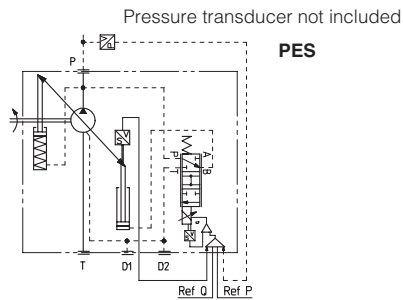

Digital P/Q controller integrates the alternate pressure and flow regulation with the electronic max power limitation. A remote pressure transducer must be installed on the system and its feedback has to be interfaced to the pump digital driver. Flow control is active when the actual system pressure is lower than the pressure reference input signal: the pump flow is regulated according to the flow reference input. Pressure control is activated when the actual pressure grows up to the pressure reference input signal: the pump flow is then reduced in order to regulate and limit the max system pressure (if the pressure tends to decrease under its command value, the flow control returns active). This option allows to realize accurate dynamic pressure profiles.

Following fieldbus interfaces are available:

- BC - CANopen interface
- BP - PROFIBUS DP interface
- EH - EtherCAT interface
- EW - POWRELINK interface
- EI - EtherNet/IP interface
- EP - PROFINET IRT interface

The pumps with BC, BP, EH, EW, EI and EP interfaces can be integrated into a fieldbus communication network and thus digitally operated by the machine control unit.

The digital control ensures high performances as flow and pressure linearity (see diagram 1), better flow knee (see diagram 2), internal leakage compensation (controlled flow independent to the load variations).

PVPC-PES

basic version, without sequence module and without pressure transducer, which has to be installed on the main line and wired to the 12 poles connector of the integral digital electronics.

PVPC-PERS

version with sequence module RESC ② which grant a minimum piloting pressure (18 bar) when the actual pressure falls below that value. Without pressure transducer.

PVPC-PERS/X

as PERS version plus integral pressure transducer, with output signal 4÷20 mA, factory wired to the pump digital electronics through a cable gland.

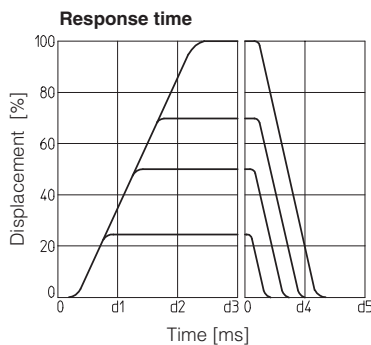

Type pump	d1	d2	d3	d4	d5
	[ms]				
PVPC-PE(R)S-3029	30	60	90	30	60
PVPC-PE(R)S-4046	40	80	120	40	80
PVPC-PE(R)S-5073	50	100	150	50	100
PVPC-PE(R)S-5090	60	120	170	60	120

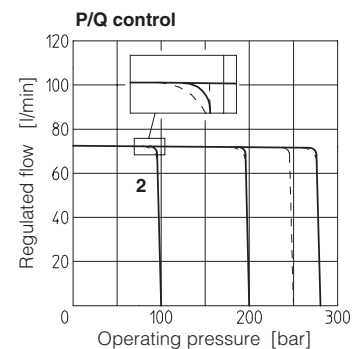
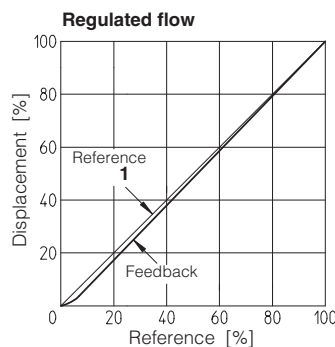

Response time of displacement variation for a step change of the electronic reference signal.

10 PRESSURE TRANSDUCER SELECTION

Standard	/S option	/X and /SX options
<p>① = remote transducer ② = main connector Note: ① and ② to be ordered separately</p>	<p>① = remote transducer ② = M12 connector Note: ① and ② to be ordered separately</p>	<p>① = integral transducer ② = M12 connector Note: ① and ② included</p>

The pressure transducer type E-ATR-8 must be ordered separately (see tech table **GS465**)

For /X option the pressure transducer with output signal 4 ÷ 20 mA is integral to the pump.

Pump code:

- PVPC-PER(S)-*/200
- PVPC-PER(S)-*/250
- PVPC-PER(S)-*/280
- PVPC-PER(S)-*/200*/C
- PVPC-PER(S)-*/250*/C
- PVPC-PER(S)-*/280*/C

Pressure transducer code:

- E-ATR-8/250
- E-ATR-8/400
- E-ATR-8/400
- E-ATR-8/250/I
- E-ATR-8/400/I
- E-ATR-8/400/I

11 ELECTRONICS OPTIONS FOR PES AND PERS

Standard execution provides on the 12 pin main connector:

- Power supply** -The power supply to the solenoids must be appropriately stabilized or rectified and filtered: apply at least a 10000 μ F/40 V capacitance to single phase rectifiers or a 4700 μ F/40 V capacitance to three phase rectifiers.
A safety fuse is required in series to each driver power supply: 2,5 A fuse time lag.
- Reference input signals** -The driver controls in closed loop both the pump flow and pressure proportionally to the external reference input signals. The driver is designed to receive two analog reference input signals both referred to the common mode signal zero (AGND). The inputs range and polarity are software selectable within the ± 10 VDC maximum range; default settings are $0 \div +10$ VDC. Driver with fieldbus interface can be software set to receive reference values directly by the machine control unit (fieldbus master); in this case the analog reference input signals can be used for start-up and maintenance operations.
- Monitor output signals** -The driver generates an analog output signals proportional to the actual pump swashplate position and to the actual pressure on the pump outlet line; the monitor output signals can be software set to show other signals available in the driver (e.g. analog reference, fieldbus reference, pilot spool position).
The output polarity is software selectable within ± 10 VDC maximum range; default settings are $0 \div +10$ VDC.
- Fault Output Signal** -Fault output signal indicates fault conditions of the driver (solenoid short circuits/not connected, reference signal cable broken for $4 \div 20$ mA input, pressure/swashplate/pilot transducer cable broken, etc.). Fault presence corresponds to 0 VDC, normal working corresponds to 24 VDC (pin 11 referred to pin2). Fault status is not affected by the status of the Enable input signal
- Enable Input Signal** -To enable the driver, supply a +VDC on pin 3 referred to pin 2: when the Enable signal is set to zero the pump functioning is disabled but the driver current output stage is still active.
(only for /S and /SX options)

Note: a minimum booting time between 400 and 800 ms has been considered from the driver energizing with the 24 VDC power supply before the valve has been ready to operate. During this time the current to the valve coils is switched to zero.

For other functions, see tech table **GS215**

11.1 Option /C

The pump electronics is set to receive $4 \div 20$ mA feedback signal from the remote pressure transducer, instead of the standard $0 \div 10$ V.

11.2 Option /I

It provides $4 \div 20$ mA current reference and monitor signals instead of the standard $0 \div +10$ VDC. It is normally used in case of long distance between the machine control unit and the pump or where the reference signal can be affected by electrical noise; the valve functioning is disabled in case of reference signal cable breakage.

11.3 Option /X (only for -PERS)

Option providing the presence of the pressure transducer, with output signal $4 \div 20$ mA, integral to the pump and factory wired to the PES electronics through a cable gland.

11.4 Option /S

Multiple pressure PID selection (only for /S and /SX options in NP execution)

Two on-off input signals are available on the main connector to select one of the four pressure PID parameters setting, stored into the driver.

Supply a 24 Vdc or a 0 Vdc on pin 9 and/or pin 10, to select one of the PID settings as indicated by binary code table at side. Gray code can be selected by software.

Logic power supply (only for /S and /SX options in BC, BP, EH, EW, EI or EP executions)

Separate power supply (pin 9,10) allow to cut solenoid power supply (pin 1,2) while maintaining active diagnostics, USB and fieldbus communication.

A safety fuse is required in series to each driver power supply: 500 mA fast fuse.

11.5 Possible combined options: /CS, /SX, /CI, /IS, /IX, /CIS and /ISX.

PIN	PID SET SELECTION			
	SET 1	SET 2	SET 3	SET 4
9	0	24 Vdc	0	24 Vdc
10	0	0	24 Vdc	24 Vdc

12 CONNECTIONS AND LEDS

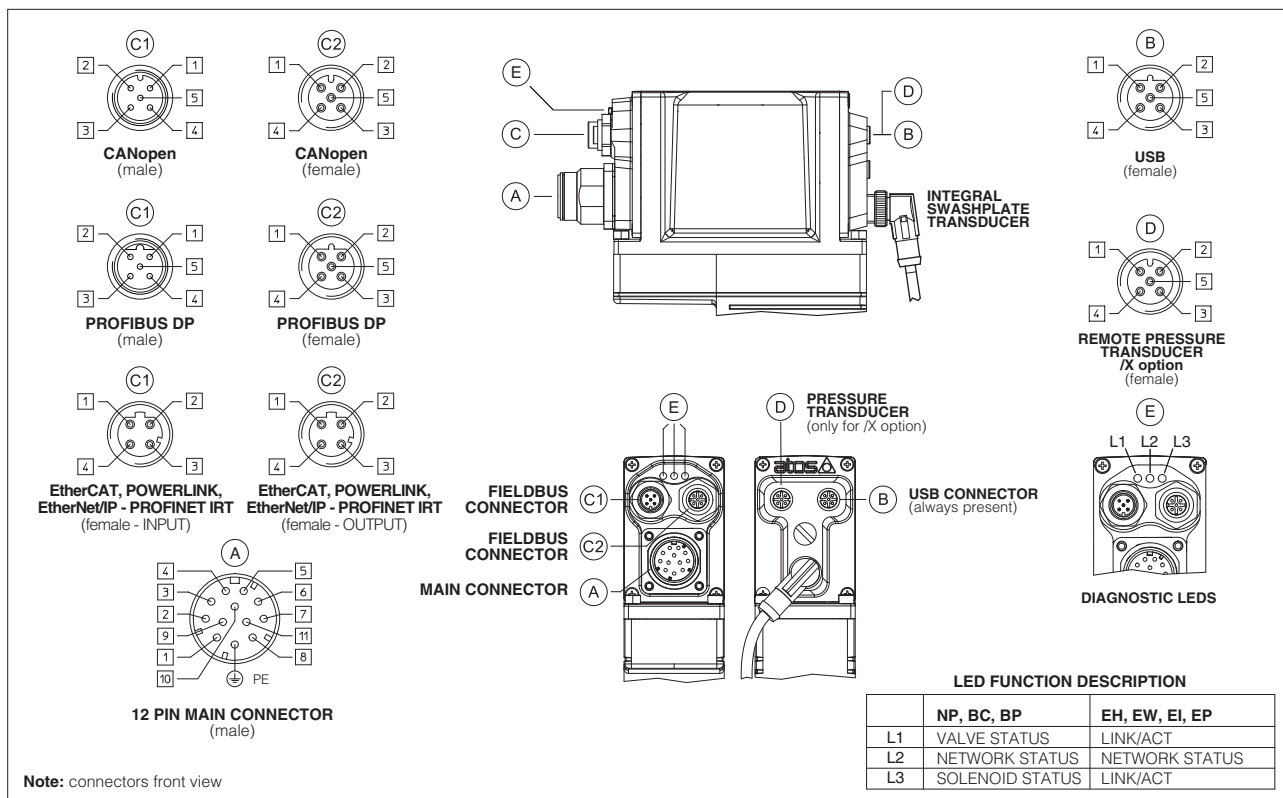

12.1 Main connector signals (Standard, Standard with /X option) - 12 pin (A)

PIN	Standard	/X	TECHNICAL SPECIFICATIONS	NOTES
1	V+		Power supply 24 Vdc Rectified and filtered: $V_{RMS} = 20 \div 32 V_{MAX}$ (ripple max 10 % V_{PP})	Input - power supply
2	V0		Power supply 0 Vdc	Gnd - power supply
3	FAULT		Fault (0 Vdc) or normal working (24 Vdc), referred to V0	Output - on/off signal
4	INPUT-		Negative reference input signal for Q_INPUT+ and P_INPUT+	Gnd - analog signal
5	Q_INPUT+		Flow reference input signal: ± 10 Vdc / ± 20 mA maximum range Defaults are 0 \div +10 Vdc for standard and 4 \div 20 mA for /I option	Input - analog signal Software selectable
6	Q_MONITOR		Flow monitor output signal: ± 10 Vdc / ± 20 mA maximum range Defaults are 0 \div +10 Vdc for standard and 4 \div 20 mA for /I option. Referred to V0	Output - analog signal Software selectable
7	P_INPUT+		Pressure reference input signal: ± 10 Vdc / ± 20 mA maximum range Defaults are 0 \div +10 Vdc for standard and 4 \div 20 mA for /I option	Input - analog signal Software selectable
8	P_MONITOR		Pressure monitor output signal: ± 10 Vdc / ± 20 mA maximum range Defaults are 0 \div +10 Vdc for standard and 4 \div 20 mA for /I option. Referred to V0	Output - analog signal Software selectable
9	D_IN		Function software selectable between: power limitation enable (default), multiple pressure PID selection or pump enable (24 Vdc) / disable (0 Vdc). Referred to V0	Input - on/off signal
10	TR+		Remote pressure transducer input signal: ± 10 Vdc / ± 20 mA maximum range Defaults are 0 \div +10 Vdc for standard and 4 \div 20 mA for /C option	Input - analog signal Software selectable
		NC	Do not connect	
11	TR-		Negative pressure transducer input signal for TR+	Input - analog signal
		NC	Do not connect	
PE	EARTH		Internally connected to driver housing	

Note: these connections are the same of Rexroth A10VSO axial piston pumps, model SYDFEE and SYDFEC

12.2 Main connector signals (/S and /SX option) - 12 pin (A)

PIN	/S and /SX		TECHNICAL SPECIFICATIONS	NOTES
	NP	Fieldbus		
1	V+		Power supply 24 Vdc Rectified and filtered: $V_{RMS} = 20 \div 32 V_{MAX}$ (ripple max 10 % V_{PP})	Input - power supply
2	V0		Power supply 0 Vdc	Gnd - power supply
3	ENABLE referred to: V0	VLO	Enable (24 Vdc) or disable (0 Vdc) the pump	Input - on/off signal
4	Q_INPUT+		Flow reference input signal: ± 10 Vdc / ± 20 mA maximum range Defaults are 0 \div +10 Vdc for standard and 4 \div 20 mA for /I option	Input - analog signal Software selectable
5	INPUT-		Negative reference input signal for Q_INPUT+ and P_INPUT+	Input - analog signal
6	Q_MONITOR referred to: V0	VLO	Flow monitor output signal: ± 10 Vdc / ± 20 mA maximum range Defaults are 0 \div +10 Vdc for standard and 4 \div 20 mA for /I option	Output - analog signal Software selectable
7	P_INPUT+		Pressure reference input signal: ± 10 Vdc / ± 20 mA maximum range Defaults are 0 \div +10 Vdc for standard and 4 \div 20 mA for /I option	Input - analog signal Software selectable
8	P_MONITOR referred to: V0	VLO	Pressure monitor output signal: ± 10 Vdc / ± 20 mA maximum range Defaults are 0 \div +10 Vdc for standard and 4 \div 20 mA for /I option	Output - analog signal Software selectable
9	D_IN0		Function software selectable between: multiple pressure PID 0 selection (default) or power limitation enable. Referred to V0	Input - on/off signal
		VL+	Power supply 24 Vdc for driver's logic and communication	Input - power supply
10	D_IN1		Function software selectable between: multiple pressure PID 1 selection (default) or power limitation enable. Referred to V0	Input - on/off supply
		VLO	Power supply 0 Vdc for driver's logic and communication	Gnd - power supply
11	FAULT referred to: V0	VLO	Fault (0 Vdc) or normal working (24 Vdc)	Output - on/off signal
PE	EARTH		Internally connected to driver housing	

Notes: these connections are the same of Moog radial piston pumps, model RKP-D
do not disconnect VLO before VL+ when the driver is connected to PC USB port

12.3 Communications connectors (B) - (C)

(B) USB connector - M12 - 5 pin always present		
PIN	SIGNAL	TECHNICAL SPECIFICATION (1)
1	+5V_USB	Supply for external USB Flash Drive
2	ID	USB Flash Drive identification
3	GND_USB	Signal zero data line
4	D-	Data line -
5	D+	Data line +

(C1) (C2) BP fieldbus execution, connector - M12 - 5 pin		
PIN	SIGNAL	TECHNICAL SPECIFICATION (1)
1	+5V	Termination supply signal
2	LINE-A	Bus line (high)
3	DGND	Data line and termination signal zero
4	LINE-B	Bus line (low)
5	SHIELD	

(C1) (C2) BC fieldbus execution, connector - M12 - 5 pin		
PIN	SIGNAL	TECHNICAL SPECIFICATION (1)
1	CAN_SHLD	Shield
2	not used	(C1) - (C2) pass-through connection (2)
3	CAN_GND	Signal zero data line
4	CAN_H	Bus line (high)
5	CAN_L	Bus line (low)

(C1) (C2) EH, EW, EI, EP fieldbus execution, connector - M12 - 4 pin		
PIN	SIGNAL	TECHNICAL SPECIFICATION (1)
1	TX+	Transmitter
2	RX+	Receiver
3	TX-	Transmitter
4	RX-	Receiver
Housing	SHIELD	

Notes: (1) shield connection on connector's housing is recommended

(2): pin 2 can be fed with external +5V supply of CAN interface

12.4 Pressure transducer connector - M12 - 5 pin - only for /S, /X, /SX options (D1) - (D2)

PIN	SIGNAL	TECHNICAL SPECIFICATION	Voltage	Current
1	VF +24V	Power supply +24Vdc	Connect	Connect
2	TR	Signal transducer ± 10 Vdc / ± 20 mA maximum range, software selectable Defaults are $0 \div +10$ Vdc for standard and $4 \div 20$ mA for /C option	Connect	Connect
3	AGND	Common GND for transducer power and signals	Connect	/
4	NC	Not Connect	/	/
5	NC	Not Connect	/	/

13 PROGRAMMING TOOLS - see tech table **GS500**

Pump's functional parameters and configurations, can be easily set and optimized using Atos E-SW programming software connected via USB port to the digital driver. For fieldbus versions, the software permits valve's parameterization through USB port also if the driver is connected to the central machine unit via fieldbus.

The software is available in different versions according to the driver's options:

E-SW-BASIC support: NP (USB) PS (Serial) IR (Infrared)
E-SW-FIELDBUS support: BC (CANopen) BP (PROFIBUS DP) EH (EtherCAT)
 EW (POWERLINK) EI (EtherNet/IP) EP (PROFINET IRT)
E-SW-*/PQ support: pumps with SP, SF, SL alternated control (e.g. E-SW-BASIC/PQ)

WARNING: drivers USB port is not isolated!

The use of isolator adapter is highly recommended for PC protection (see table **GS500**)

13.1 - USB connection

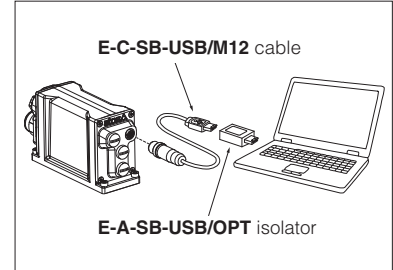

14 DIMENSIONS OF PVPC PUMPS

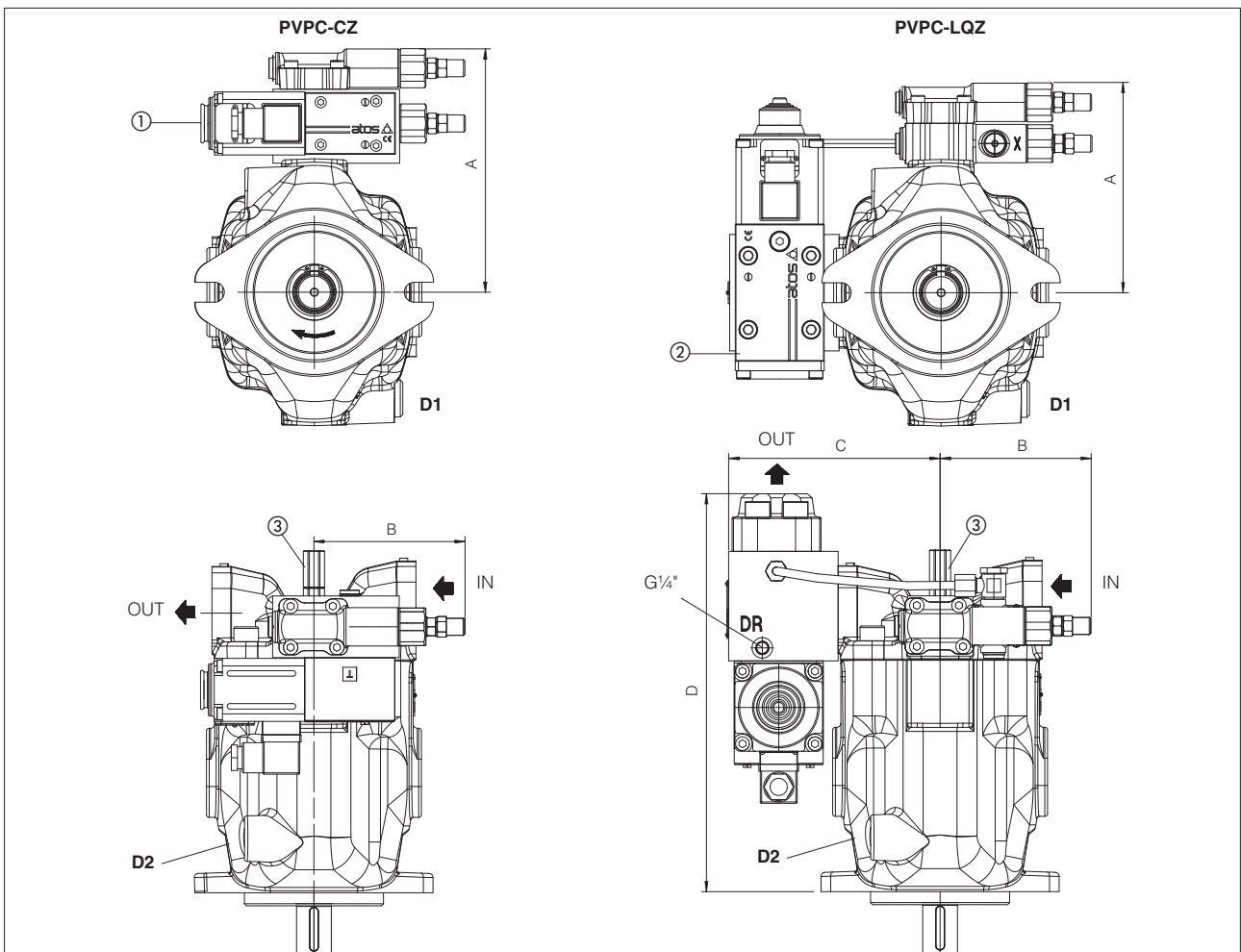

① = Proportional pressure control valve

② = Proportional flow control valve

③ = Regulation screw for max displacement. Adjustable range 50% to 100% of max displacement (not available for versions PES, PERS and PERS(X).

In case of double pump the regulation screw is not always available, please contact our technical office.

Drawing shows pumps with clockwise rotation (option D): pumps with counterclockwise rotation (option S) will have inlet and outlet ports inverted and consequently also the position of the control devices.

Pump type	Version	A	B	C	D	IN	OUT	D1, D2	Mass (kg)
PVPC-*-3029	CZ	168	111	-	-	Flange SAE 3000 1 1/4"	Flange SAE 6000 3/4"	1/2" BSPP	22
	LQZ	144	111	132	257	Flange SAE 3000 1 1/2"	Flange SAE 6000 1"	1/2" BSPP	24
PVPC-*-4046	CZ	177	111	-	-	Flange SAE 3000 1 1/2"	Flange SAE 6000 1"	1/2" BSPP	28
	LQZ	153	111	156	293	Flange SAE 3000 1 1/2"	Flange SAE 6000 1"	1/2" BSPP	33,6
PVPC-*-5073	CZ	190	111	-	-	Flange SAE 3000 2"	Flange SAE 6000 1 1/4"	3/4" BSPP	36,9
	LQZ	166	111	163	328	Flange SAE 3000 2"	Flange SAE 6000 1 1/4"	3/4" BSPP	44

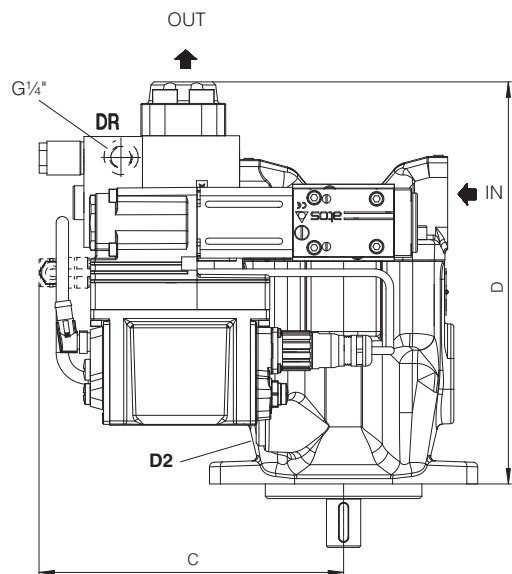
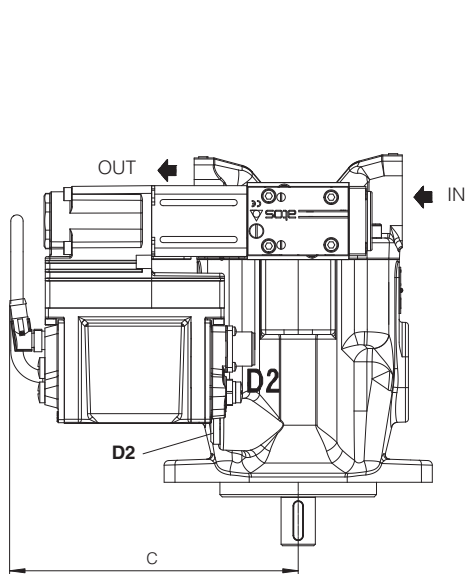
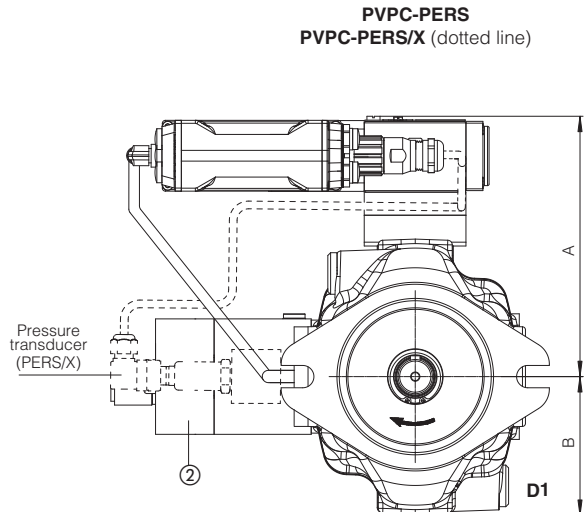
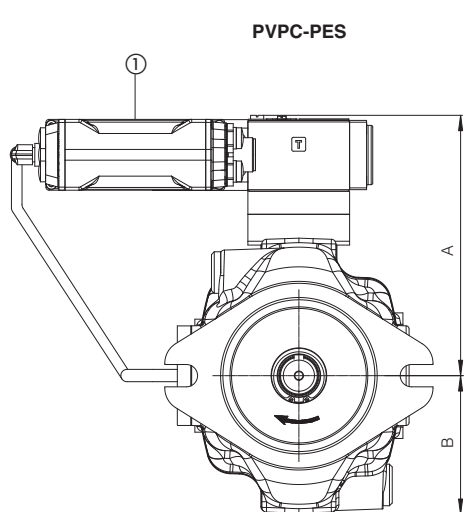

- ① = Proportional valve with integral digital P/Q controller
- ② = Sequence module

Drawing shows pumps with clockwise rotation (option D): pumps with counterclockwise rotation (option S) will have inlet and outlet ports inverted and consequently also the position of the control devices.

Pump type	Version	A	B	C	D	IN	OUT	D1, D2	Mass (kg)
PVPC-*-3029	PES	170	103,5	190	-				21,6
	PERS	170	103,5	200	262,5	Flange SAE 3000 1 1/4"	Flange SAE 6000 3/4"	1/2" BSPP	26
	PERS/X	190	103,5	200	262,5				26,4
PVPC-*-4046	PES	178	103,5	190	-				27,6
	PERS	178	103,5	220	299	Flange SAE 3000 1 1/2"	Flange SAE 6000 1"	1/2" BSPP	33,7
	PERS/X	178	103,5	220	299				34,1
PVPC-*-5073 PVPC-*-5090	PES	190	103,5	190	-				36,6
	PERS	190	103,5	230	337	Flange SAE 3000 2"	Flange SAE 6000 1 1/4"	3/4" BSPP	46,7
	PERS/X	190	103,5	230	337				47,1