

ISO cartridge valves type **LIDEW*** and **LIDBH***

directional control, ISO 7368 size from 16 to 100, high flow, **Pmax 420 bar**

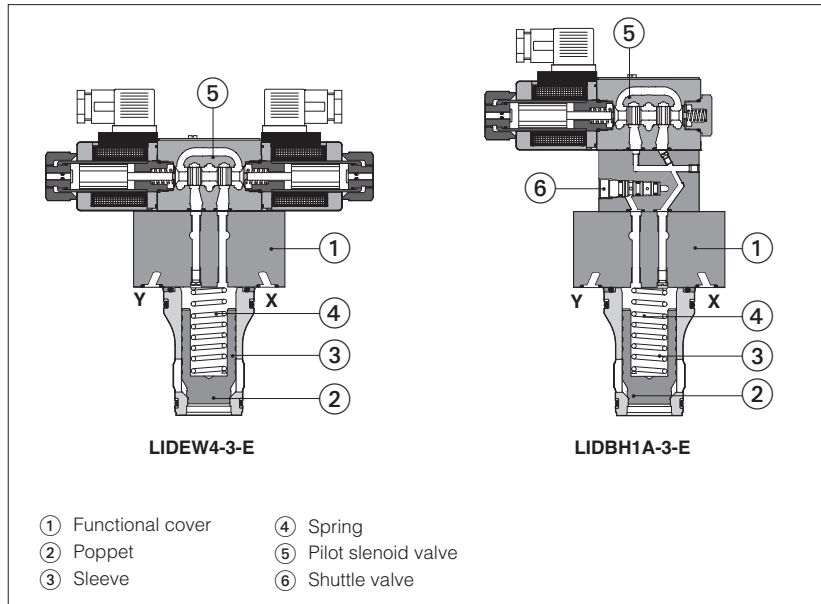

Directional control valves in ISO cartridge design, used to intercept or to permit the flow passage according to the selected pilot control. They are made by a functional cover ① and a 2-way **SC LI** slip-in cartridge.

LIDEW: functional cover with pilot solenoid valve for cartridge operation, available in different configurations depending to the function to be performed.

LIDBH as LIDEW plus shuttle valve for pilot pressure selection.

The SC LI slip-in cartridge is available with different poppet shape to optimize the control, see section ⑥.

It is made by a poppet ② sliding into a sleeve ③ and kept in normally closed position by the spring ④ available with different cracking pressure values.

Size: **16 to 100** (ISO 7368)

Max flow up to **9000 l/min** at $\Delta p = 5 \text{ bar}$

Max pressure up to **420 bar**

1 MODEL CODE OF FUNCTIONAL COVERS - for model code of slip-in cartridge, see section ⑤

LI	D	EW	1	-	3	/	*	-	E	X	24DC	**	/	*	*
Cover according to ISO 7368	D = directional function	EW = with pilot solenoid valve BH = as EW plus shuttle valve for pilot selection												Optional different setting of calibrated plugs in the pilot channels, see sections ③, ④	
Cover configuration see section ② LIDEW: -, 1, 2, 4, 5, 6 LIDBH: 1A, 1C, 2A, 2C															
Size: 1 = 16 2 = 25 3 = 32 4 = 40 5 = 50 6 = 63 8 = 80 10 = 100															
Options, see section ③															
Seals material: - = NBR PE = FKM BT = HNBR															
Series number															
Voltage code see section ⑧															
X = without connector See section ② for available connectors, to be ordered separately 00 = solenoid valve without coils (for I) 00-AC = AC solenoid valve without coils (for E and EP) 00-DC = DC solenoid valve without coils (for E and EP)															
Pilot solenoid valve (1) for size 1 to 6: I = DHI, Pmax 350 bar E = DHE, Pmax 350 bar EP = DHEP, Pmax 420 bar for size 8 and 10: E = DKE, Pmax 350 bar EP = DKEP, Pmax 420 bar															

(1) for solenoid valve's characteristics, see following technical tables:

DHI	tech. table E010
DHE	tech. table E015
DHEP	tech. table TE030
DKE	tech. table E025
DKEP	tech. table TE030

2 HYDRAULIC SYMBOLS (cover configuration)

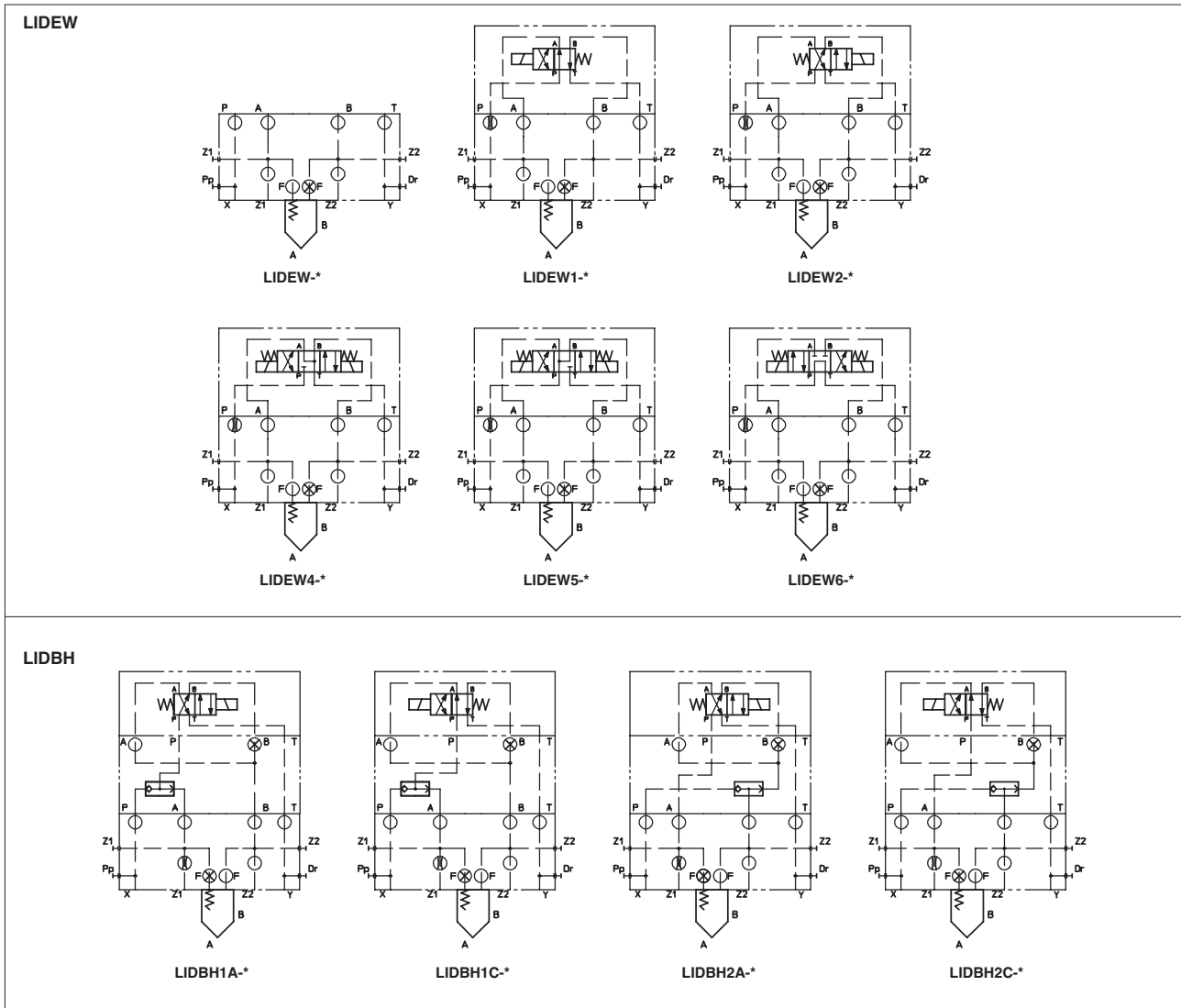

3 OPTIONS

For LIDEW*, LIDBH* covers (sizes 40...100):

/E = with external attachments Pp and underneath port X supplied plugged;

For all the models:

/B = cartridge piloted via port "B" of solenoid pilot valve;

/F = prearranged for coupling to an intermediate element with poppet position detector for safety function. See tab. EY120.

/W/P = prolonged manual override protected by rubber cap for solenoid pilot valve. See table K150.

*** = Calibrated plugs different from standard ones reported in section 7. The restrictors configuration (if different from the standard) must be indicated at the end of the model code:

LIDEW2	-	1	/*	EX	24DC	**	P	06
							Channel where the orifice has to be provided: P = channel X, port P Z1 = channel Z1 F = channel F Z2 = channel Z2	Size of the throttling hole in teths of millimeters: 05 = 0,5 mm 10 = 1 mm 17 = 1,7 mm 06 = 0,6 mm 12 = 1,2 mm 20 = 2 mm 08 = 0,8 mm 15 = 1,5 mm

4 STANDARD ORIFICES CONFIGURATION

Cover \ Port	LIDEW*-1 LIDBH*-1	LIDEW*-2 LIDBH*-2	LIDEW*-3 LIDBH*-3	LIDEW*-4 LIDBH*-4	LIDEW*-5 LIDBH*-5	LIDEW*-6 LIDBH*-6	LIDEW*-8 LIDBH*-8	LIDEW*-10 LIDBH*-10
Z1 (only for LIDBH*-*)	M4 12A	M4 12A	M6 15A	M6 17A	M6 20A	M6 20A	M8 20A	M8 20A
P	M6 12A	M6 12A	M6 15A	M6 17A	M6 20A	M6 20A	M8 20A	M8 25A

M4 ÷ M8 = screw size; **12A ÷ 20A** = calibrated orifices diameter in tenths of mm; **A** = short calibrated hole

5 MODEL CODE OF SLIP-IN CARTRIDGES

SC LI	-	16	43	1	40	/	*
Cartridge according to ISO 7368							
Size, the same of relevant cover: 16 25 32 40 50 63 80 100							
Type of poppet 32, 33 (size 16 to 100) = without damping nose 42 (size 16 to 80) = as 32 but with damping nose 43 (size 16 to 100) = as 33 but with damping nose							
				Series number (1) High flow: 40 = all sizes Standard flow: 31 = size 16 to 50 11 = size 63 and 80 10 = size 100		Seals material: - = NBR PE = FKM BT = HNBR	
				Spring cracking pressure: 1 = 0,3 bar for poppet 32, 42 1 = 0,6 bar for poppet 33, 43		2 = 1,5 bar for poppet 32, 42 3 = 3 bar for all poppets 6 = 5,5 bar for all poppets	

(1) New high flow series 40 is mechanically interchangeable with standard flow series 31, 11 and 10 - cavity according to ISO 7368

6 TYPE OF POPPET

Type of poppet	32	33	42	43
Functional sketch (Hydraulic symbol)				

6.1 new high flow series 40

Operating pressure		420 bar max			
Nominal flow at Δp 5bar (l/min) see diagrams Q/ Δp at section 9	Size 16	270	270	240	240
	25	550	550	500	500
	32	1000	1000	800	800
	40	1700	1700	1400	1400
	50	2500	2500	2200	2200
	63	4000	4000	3300	3300
	80	5500	5500	4000	4000
	100	9000	9000	-	6300
Typical section					
Area ratio A:Ap		1:1,1	1:1,5	1:1,1	1:1,5
Cracking pressure A→B	Spring 1	0,3 bar	0,6 bar	0,3 bar	0,6 bar
	2	1,5 bar	-	1,5 bar	-
	3	3 bar	2,5 bar	3 bar	2,5 bar
Cracking pressure B→A	Spring 1	3 bar	0,9 bar	3 bar	0,9 bar
	2	12,8 bar	-	12,8 bar	-
	3	32,5 bar	3,8 bar	32,5 bar	3,8 bar
	6	59,4 bar	9 bar	59,4 bar	9 bar

6.2 standard flow series 31, 11, 10

Operating pressure		420 bar max			
Nominal flow at Δp 5bar (l/min) see diagrams Q/ Δp at section 9	Size 16	170	150	140	120
	25	400	300	350	280
	32	610	450	480	430
	40	1300	1000	1100	850
	50	1700	1500	1350	1300
	63	2800	2400	2400	1800
	80	4200	3600	3600	3000
	100	7200	6200	-	5000
Typical section					
Area ratio A:Ap		1:1,1	1:2 for size 16, 25	1:1,1	1:2 for size 16, 25
Cracking pressure A→B	Spring 1	0,3 bar	0,6 bar	0,4 bar	0,6 bar
	2	1,5 bar	-	-	1,3 bar
	3	3 bar	2,5 bar	2,1 bar	2,7 bar
Cracking pressure B→A	Spring 1	3 bar	0,5 bar	0,7 bar	0,5 bar
	2	12,8 bar	-	-	12,8 bar
	3	32,5 bar	2,5 bar	3,7 bar	2,4 bar
	6	59,4 bar	6 bar	7,5 bar	6 bar

7 MAIN CHARACTERISTICS, SEALS AND HYDRAULIC FLUIDS - for other fluids not included in below table, consult our technical office

Assembly position / location	Any position		
Subplate surface finishing	Roughness index Ra 0,4 - flatness ratio 0,01/100 (ISO 1101)		
MTTFd values according to EN ISO 13849	150 years, for further details see technical table P007		
Ambient temperature	Standard execution = -30°C ÷ +70°C /PE option = -20°C ÷ +70°C /BT option = -40°C ÷ +70°C		
Seals, recommended fluid temperature	NBR seals (standard) = -20°C ÷ +60°C, with HFC hydraulic fluids = -20°C ÷ +50°C FKM seals (/PE option)= -20°C ÷ +80°C HNBR seals (/BT option)= -40°C ÷ +60°C, with HFC hydraulic fluids = -40°C ÷ +50°C		
Recommended viscosity	15÷100 mm ² /s - max allowed range 2.8 ÷ 500 mm ² /s		
Fluid contamination class	ISO 4406 class 21/19/16 NAS 1638 class 10, in line filters of 25 µm (β ₂₅ ≥75 recommended)		
Hydraulic fluid	Suitable seals type	Classification	Ref. Standard
Mineral oils	NBR, FKM, HNBR	HL, HLP, HLPD, HVLP, HVLPD	DIN 51524
Flame resistant without water	FKM	HFDU, HFDR	ISO 12922
Flame resistant with water	NBR, HNBR	HFC	
Flow direction	From A→B or B→A		
Functional cover operating pressure	Pilot valve I	Ports A, B, X, Z1, Z2: 350 bar	Port Y: 120 bar
	Pilot valve E	Ports A, B, X, Z1, Z2: 350 bar	Port Y: 210 bar for DC version; 160 bar for AC version
	Pilot valve EP	Ports A, B, X, Z1, Z2: 420 bar	Port Y: 210 bar for DC version; 160 bar for AC version

7.1 Coils characteristics

Insulation class	Pilot valve E, EP: H (180°C) for DC coils F (155°C) for AC coils Pilot valve I: H (180°C) for DC or AC coils Due to the occurring surface temperatures of the solenoid coils, the European standards EN ISO 13732-1 and EN ISO 4413 must be taken into account
Protection degree to DIN EN 60529	IP 65 (with connectors 666, 667, 669 correctly assembled)
Relative duty factor	100%
Supply voltage and frequency	See electric feature 8
Supply voltage tolerance	± 10%
Certification	cURus North American Standard

8 ELECTRIC FEATURES

Solenoid valve type	External supply nominal voltage ± 10% (1)	Voltage code	Type of connector	Power consumption (3)	Code of spare coil DHI	Colour of coil label DHI	Code of spare coil DHE, DHEP
DHI DHE DHEP	DC	12 DC 24 DC 110 DC 220 DC	666 or 667	33 W (DHI) 30 W (DHEP)	COU-12DC COU-24DC COU-110DC COU-220DC	green red black black	COE-12DC COE-24DC COE-110DC COE-220DC
	AC	110/50 AC (2) 115/60 AC 120/60 AC 230/50 AC (2) 230/60 AC	666 or 667	60 VA (DHI) 58 VA (DHEP) (4)	COI-110/50/60AC - COI-120/60AC COI-230/50/60AC COI-230/60AC	yellow - white light blue silver	COE-110/50/60AC COE-115/60AC - COE-230/50/60AC COE-230/60AC
DKE DKEP	12 DC 14 DC 24 DC 28 DC 110 DC 220 DC	12 DC 14 DC 24 DC 28 DC 110 DC 220 DC	666 or 667	36 W	CAE-12DC CAE-14DC CAE-24DC CAE-28DC CAE-110DC CAE-220DC	-	
	110/50/60 AC (2) 230/50/60 AC (2) 115/60 AC 230/60 AC	110/50/60 AC 230/50/60 AC 115/60 AC 230/60 AC			100 VA (7) 130 VA (7)		
	110/50/60 AC 230/50/60 AC	110 DC 220DC	669	36 W	CAE-110DC CAE-220DC		

- (1) For other supply voltages available on request see technical tables E010, E015, E025, TE030.
(2) Coil can be supplied also with 60 Hz of voltage frequency: in this case the performances are reduced by 10 ÷ 15%. The power consumption is 55 VA (DHI), 58 VA (DHE, DHEP) and 90 VA (DKE, DKEP)
(3) Average values based on tests performed at nominal hydraulic condition and ambient/coil temperature of 20°C.
(4) When solenoid is energized, the inrush current is approx 3 times the holding current. Inrush current values correspond to a power consumption of about 150 VA.
(5) Only for DHE, DHEP
(6) Only for DHI
(7) When solenoid is energized, the inrush current is approx 3 times the holding current.

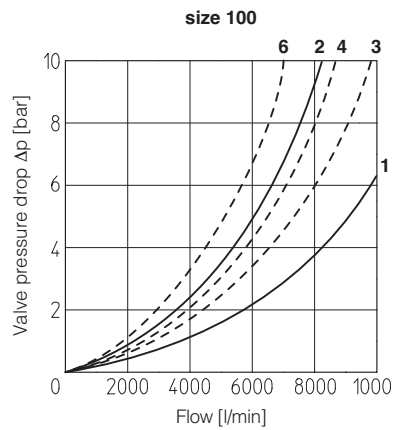
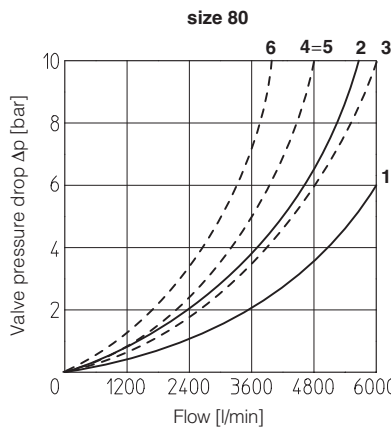
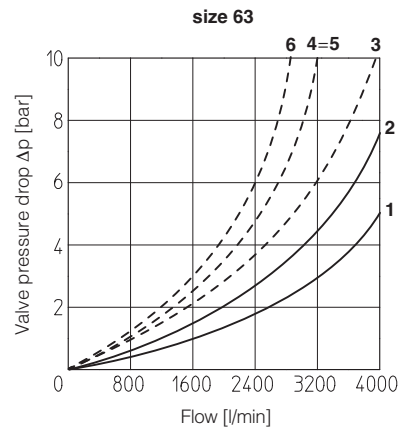
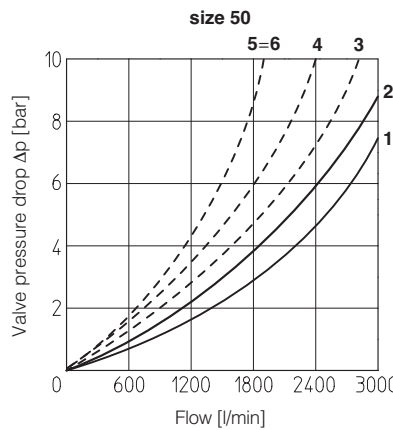
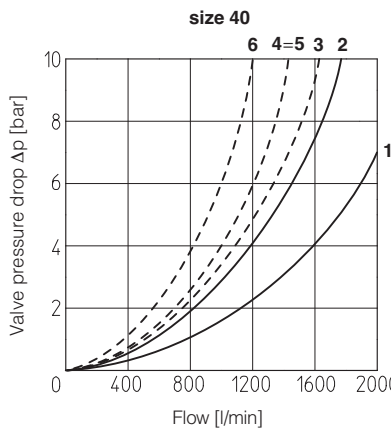
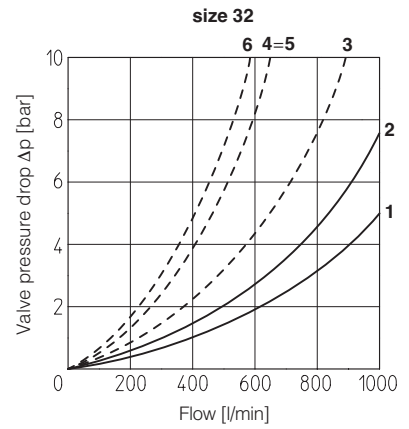
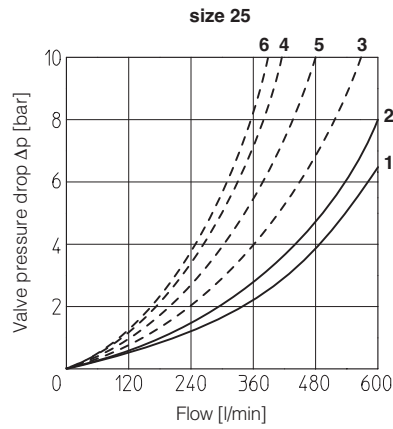
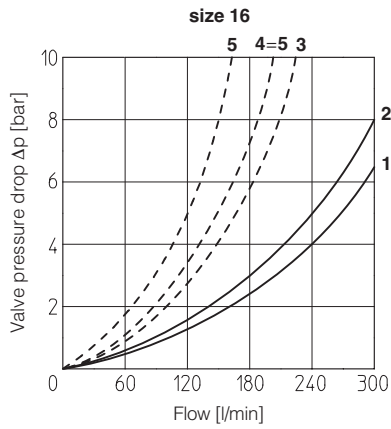

SC LI New high flow - series 40

- 1 = poppet type 32 and 33
- 2 = poppet type 42 and 43

SC LI Standard flow - series 31 (size 16 to 50), 11 (size 63 and 80), 10 (size 100)

- 3 = poppet type 32
- 4 = poppet type 33
- 5 = poppet type 42
- 6 = poppet type 43

10 COVER DIMENSIONS [mm] - for mounting interface and cavity dimensions see tech. table P006

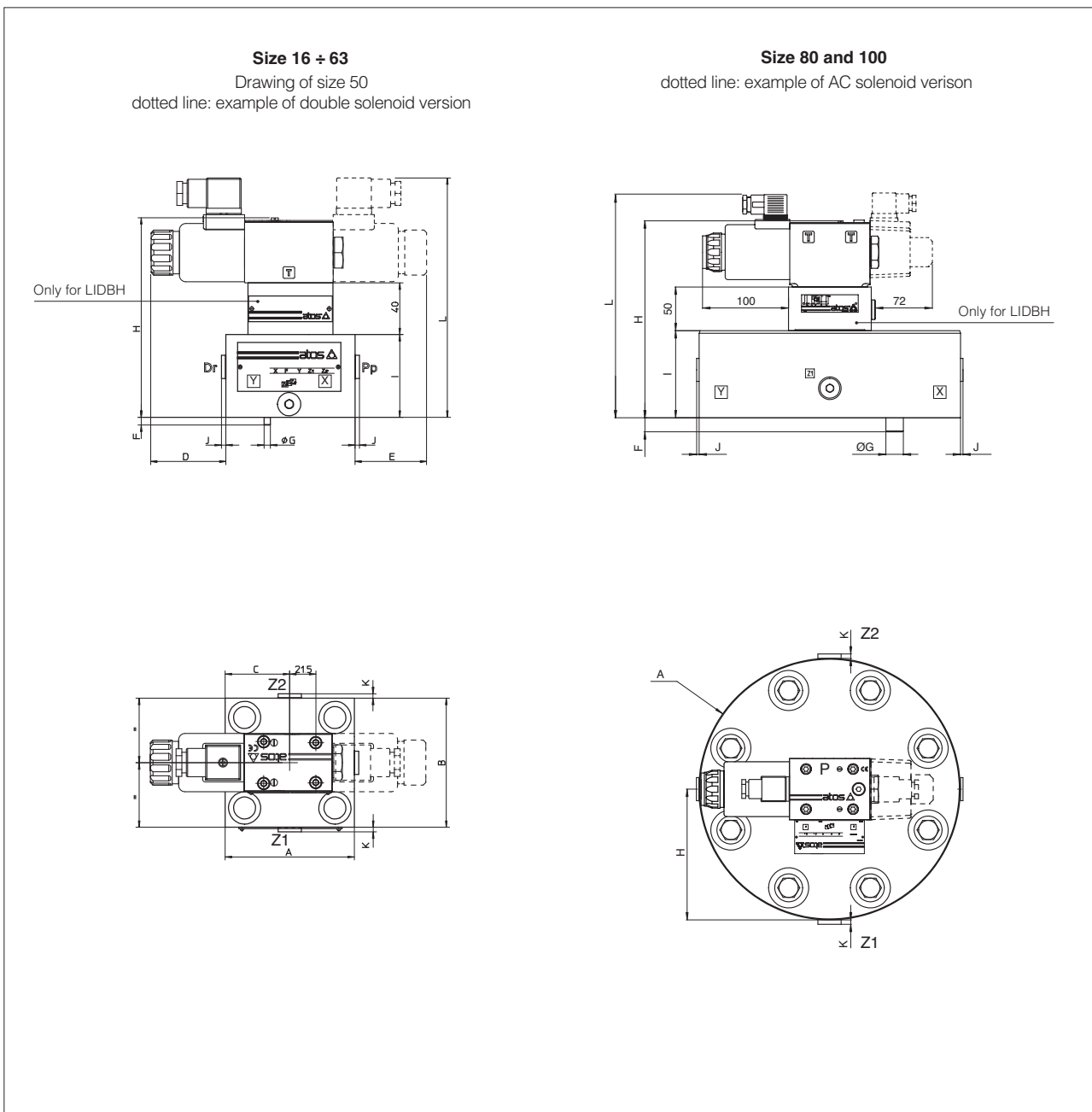

Notes referred to the below table:

- (1) LIDEW1*, LIDBH*A: solenoid at side of port Y of cover;
LIDEW2*, LIDBH*C: solenoid at side of port X of cover;

Size (1)	A	B	C	D max	E max	F	G	H max LIDEW	H max LIDBH	I	L max	J	K	Ports Pp-Dr	Ports Z1-Z2	Seals	Fastening bolts	Tightening torque [Nm]	Mass [Kg]
16	70	65	29	83,5	70,5	4	3	90,5	130,5	40	125	-	-	-	-	4 OR-108	Nr. 4 M8x45	35	2,6 ÷ 3
25	85	85	42,5	69,5	69,5	6	5	90,5	130,5	40	125	-	-	-	-	4 OR-108	Nr. 4 M12x45	125	3 ÷ 3,4
32	100	100	50	62,5	42,5	6	5	100,5	140,5	50	135	-	-	-	-	4 OR-2043	Nr. 4 M16x55	300	3,5 ÷ 4
40	125	125	62,5	49,5	49,5	6	5	110,5	150,5	60	145	3,5	-	G 1/4	-	4 OR-3043	Nr. 4 M20x70	600	6,4 ÷ 6,9
50	140	140	70	42	42	4	6	120,5	160,5	70	155	3,5	3,5	G 1/4	G 1/4	4 OR-3043	Nr. 4 M20x80	600	9,5 ÷ 10
63	180	180	90	22	22	4	6	130,5	170,5	80	165	3,5	3,5	G 3/8	G 3/8	4 OR-3050	Nr. 4 M30x90	2100	17,3÷17,7
80	Ø250	-	125	-	-	6	8	152,5	202,5	80	187	3,5	3,5	G 3/8	G 3/8	4 OR-4075	Nr. 8 M24x90	1000	27,1÷27,7
100	Ø300	-	150	-	-	8	10	182,5	222,5	100	217	3,5	3,5	G 1/2	G 1/2	4 OR-4093	Nr. 8 M30x120	2100	53÷54

Overall dimensions refer to the pilot valves with connectors type 666