



A Polyhydron Group Company

DIRECT ACTING PRESSURE RELIEF VALVE Model : DPR

ENGINEERING

1 of 6

Ref. No. D04896

Release 05 / 2014

Description

- Direct acting valve.
- Guided poppet design.
- Cushion arrangement for greater stability and noise control.
- Three sizes. - 06, 10 and 20.
- Three mounting styles - Threaded cartridge.
 Threaded port body.
 Subplate Type (Factory Std. & ISO Std.)
- Six pressure ranges - Upto 25, 50, 100, 200, 315 & 400.
 - 700 bar. (in size 06 only)
- Two options for pressure adjustment - With set screw and Lock nut.
 With hand knob.



Section

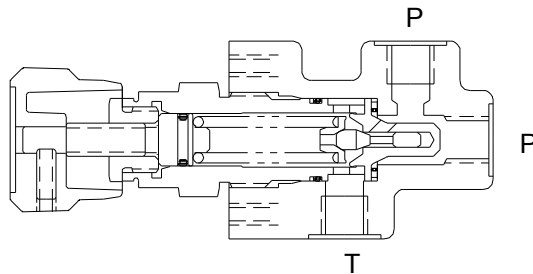

Hydraulic Symbol

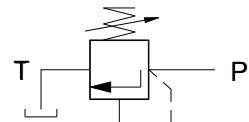

Unit dimensions

Threaded cartridge and cavity details

Dimensions in mm.

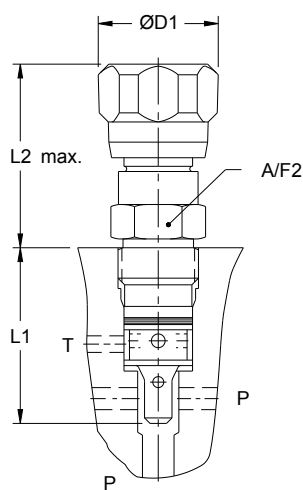

Cartridge with hand knob for pr. adjustment.

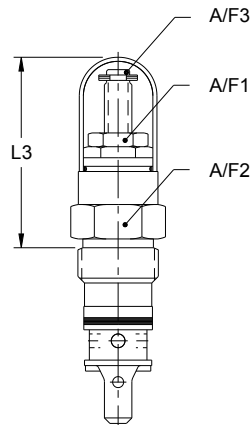

Cartridge with set screw for pr. adjustment.

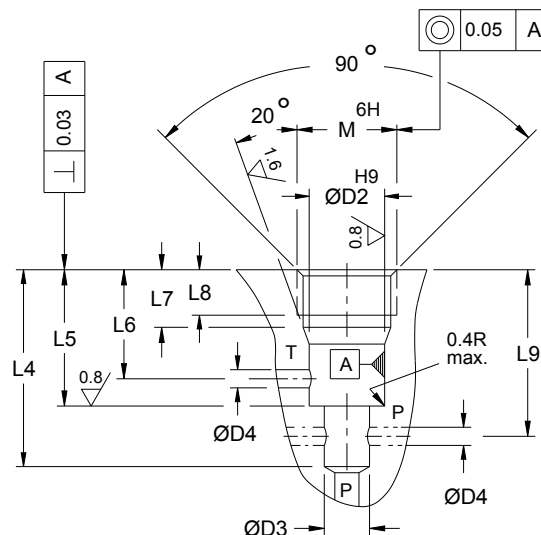

Cartridge cavity machining details.

Table 1.

Size	Mass Kg.	A/F1	A/F2	A/F3	M ^{6H}	ØD1	ØD2	ØD3	ØD4	L1	L2	L3	L4±0.5	L5±0.2	L6±0.2	L7±0.2	L8	L9	Tightning torque Nm.
6	0.45	19	30	4	M28 x 1.5	43	25	15	6	64	64	65	65	45	35	19	15	55	120
10	0.9	19	36	5	M35 x 1.5	48	32	19	10	77	82	80	80	52	41	23	18	69	140
20	1.6	19	46	5	M45 x 1.5	60	40	24	20	103	85	79	110	70	54	27	21	92	170

Polyhydron Pvt. Ltd.

78-80, Machhe Industrial Estate,
Machhe, Belgaum - 590 014. INDIA.

Phone : +91-(0)831-2411001
Fax : +91-(0)831-2411002
E-mail : polyhydron@gmail.com
Website : www.polyhydron.com



A Polyhydron Group Company

DIRECT ACTING PRESSURE RELIEF VALVE Model : DPR

ENGINEERING

2 of 6

Ref. No. D04896

Threaded port body

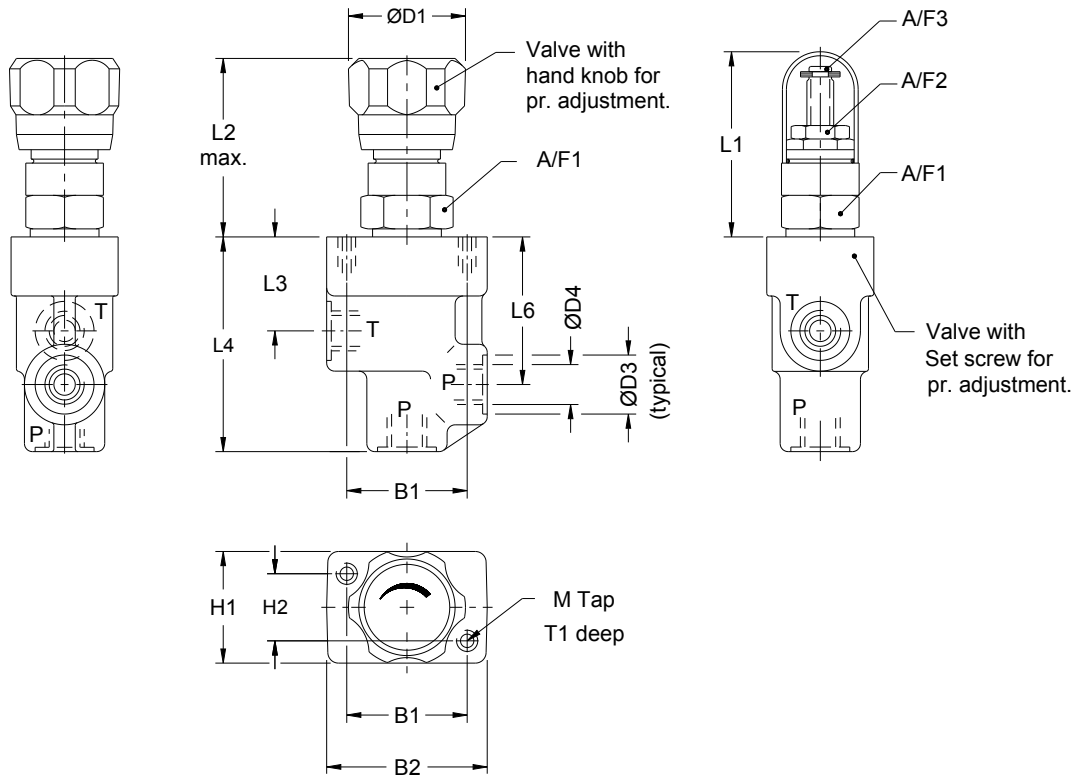

Table 2.

Size	Mass Kg	B1	B2	ØD1	ØD2	ØD4	M	A/F1	A/F2	A/F3	L1	L2	L3	L4	L6	H1	H2	T1
06	1.2	45	60	43	22	G1/4	M6	30	19	4	65	64	35	80	55	40	25	11
10	2.8	60	80	48	30	G1/2	M8	36	19	5	80	82	42	100	69	60	40	15
20	6.2	70	100	60	44	G1	M8	46	19	5	78.5	85	54	135	85	70	50	15

Subplate type (Factory Standard)

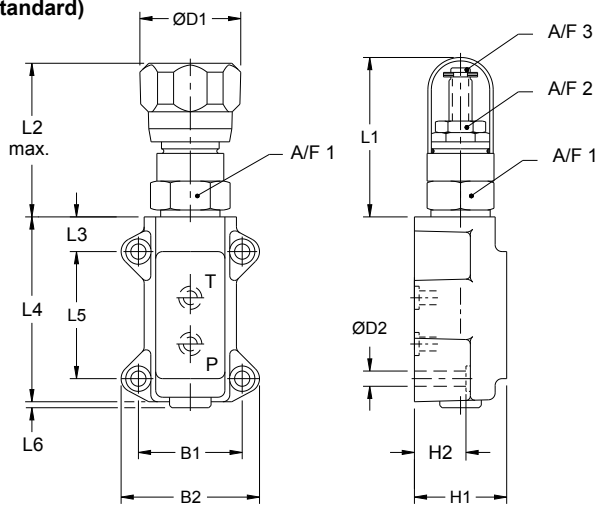
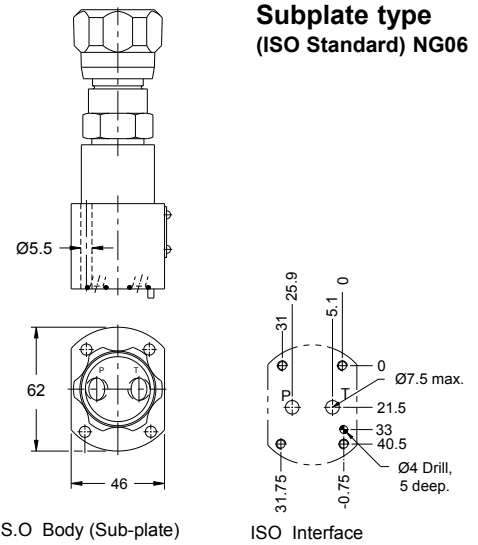

Table 3.

Size	Mass Kg.	B1	B2	ØD1	ØD2	A/F1	A/F2	A/F3	L1	L2	L3	L4	L5	L6	H1	H2
6	1.1	45	60	43	6.6	30	19	4	65	64	15	80	55	4	40	21
10	2.4	60	80	48	9	36	19	5	80	82	20	100	70	5	55	28
20	8	70	100	60	9	46	19	5	78.5	85	20	135	100	5	70	70

Subplate type (ISO Standard) NG06





A Polyhydron Group Company

DIRECT ACTING PRESSURE RELIEF VALVE Model : DPR

ENGINEERING

3 of 6

Ref. No. D04896

Subplate

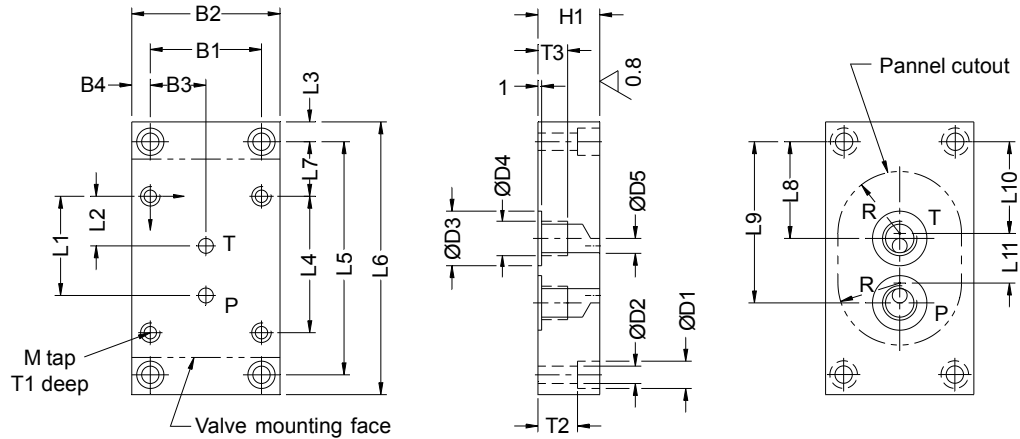

Table 4.

Size	Model	Mass	B1	B2	B3	B4	M	ØD1	ØD2	ØD3	ØD4	ØD5	H1	L1	L2	L3	L4	L5
6	1NSR03G02	1.2	45	60	22.5	7.5	M6	11	7	22	G1/4	6	25	40	20	8	55	94
10	1NSR05G03	2.4	60	80	30	10	M8	11	7	25	G3/8	10	30	45	21	10	70	115
10	1NSR05G04	2.4	60	80	30	10	M8	11	7	30	G1/2	10	30	45	21	10	70	115
20	1NSR07G08	5.3	70	100	35	15	M8	17.5	11.5	44	G1	20	40	65	34	15	100	140

Size	Model	L6	L7	L8	L9	L10	L11	T1	T2	T3	R	Valve fixing screws S.H.C.S.	Tightening Torque
6	1NSR03G02	110	22	65	39	37	20	10	16	12	25	M6 x 30 L4 Nos. (10.9)	15 N m
10	1NSR05G03	135	27.5	80.5	40.5	47.5	20	12	16	12	35	M8 x 40 L4 Nos. (10.9)	35 N m
10	1NSR05G04	135	27.5	80.5	40.5	47.5	20	12	16	14	35	M8 x 40 L4 Nos. (10.9)	35 N m
20	1NSR07G08	170	20	97	42	50	40	22	27	20	40	M8 x 80 L4 Nos. (10.9)	35 N m

Technical specifications

Construction	Direct acting, Poppet type.
Mounting style	Threaded Cartridge, Threaded Port body or Subplate Type (Factory Std. & ISO Std.)
Interface	Factory standard
	Note : Subplate mounting valves having interface as per ISO 6264-03-04 and ISO 6264-06-09 are also available on request. Please ask for details
Mounting position	Optional.
Flow direction	From P to T
Operating pressure for port P	400 bar. (Standard model)
for port P	700 bar max.(for Model DPR06*700-11 only)
for port T	315 bar.
Pressure setting ranges	Upto 25, 50, 100, 200, 315, 400 and 700 bar max.
Hydraulic medium	Mineral Oil
Viscosity range	10 Cst. to 380 Cst
Fluid temperature range	-20 °C to +70 °C
Fluid cleanliness requirement	As per ISO 16/13 or better.
Mass	Refer individual table.



A Polyhydon Group Company

DIRECT ACTING PRESSURE RELIEF VALVE Model : DPR

ENGINEERING

4 of 6

Ref. No. D04896

Ordering Code

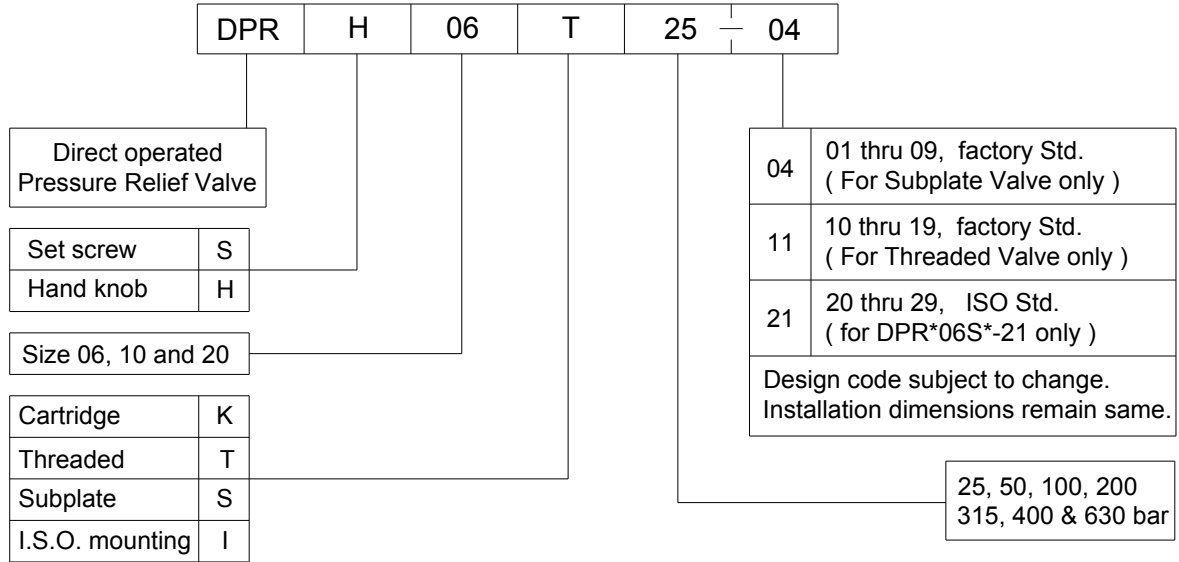

Note : Subplate to be ordered separately.

All rights reserved.
Subject to revision.



A Polyhydon Group Company

DIRECT ACTING PRESSURE RELIEF VALVE Model : DPR

ENGINEERING

5 of 6

Ref. No. D04896

Sectional View and Part List

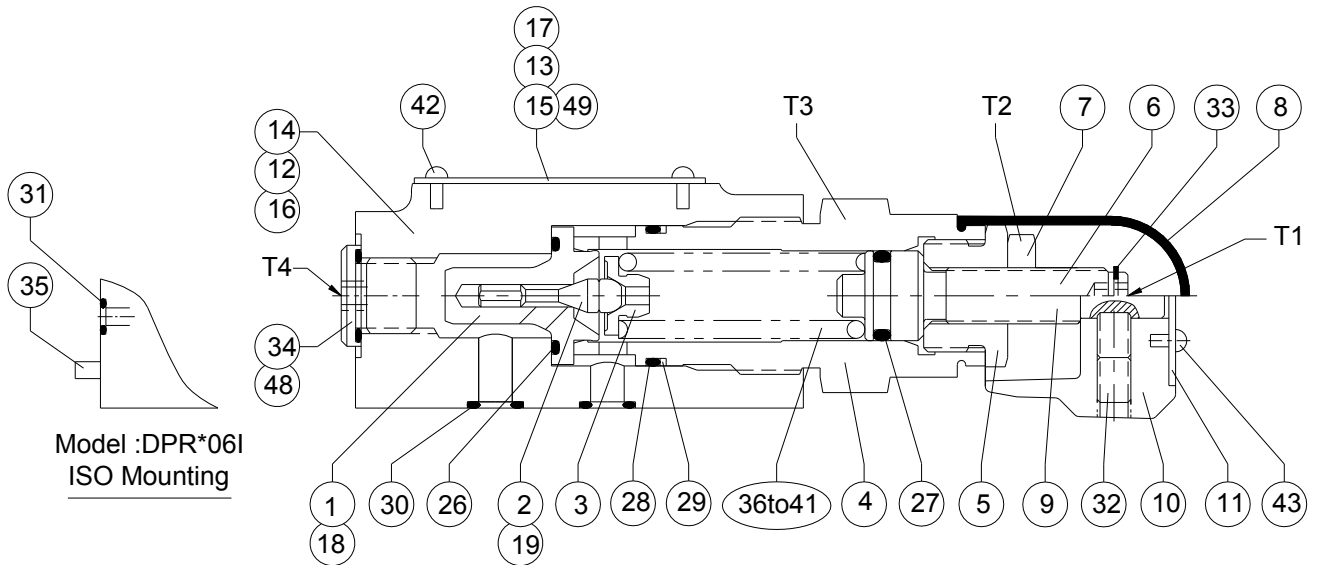

Model :DPR*06I
ISO Mounting

Hydraulic symbol

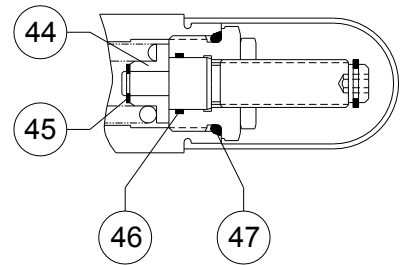
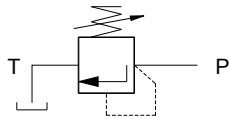

Tools required

			Size DPR06	Size DPR10	Size DPR20
T1	Wrench key	1	4 A/F	5 A/F	5 A/F
T2	Spanner	1	19 A/F	19 A/F	19 A/F
T3	Spanner	1	30 A/F	36 A/F	46 A/F
T4	Wrench key	1	6 A/F	10 A/F	6/17 A/F



A Polyhydron Group Company

**DIRECT ACTING
PRESSURE RELIEF VALVE
Model : DPR**

ENGINEERING

6 of 6

Ref. No. D04896

Sl.no.	Description	Size DPR 06			Size DPR 10			Size DPR 20		
		Part no.	Size.	Qty.	Part no.	Size.	Qty.	Part no.	Size.	Qty.
1	Valve seat	20101	--	01	20201	--	01	20301	--	01
2	Poppet	20102	--	01	20202	--	01	20302	--	01
3	Spring pad	20103	--	01	20203	--	01	20303	--	01
4	Spring casing	20104	--	01	20204	--	01	20304	--	01
5	Top nut	20105	--	01	20205	--	01	20305	--	01
6	Adjusting screw (Set pr.)	20106	--	01	20206	--	01	20306	--	01
7	Check nut	20107	--	01	20207	--	01	20307	--	01
8	Cap	20108	--	01	20208	--	01	20308	--	01
9	Adjusting screw (Hand knob)	20109	--	01	20209	--	01	20309	--	01
10	Hand knob	20110	--	01	20210	--	01	20310	--	01
11	Label (Regulation)	20111	--	01	20211	--	01	20311	--	01
12	Body (Threaded)	20112	--	01	20212	--	01	20312	--	01
13	Label (Threaded)	20113	--	01	20213	--	01	20313	--	01
14	Body (Subplate)	20114	--	01	20214	--	01	20314	--	01
15	Label (Subplate)	20115	--	01	20215	--	01	20315	--	01
16	Body (ISO mounting)	20116	--	01	--	--	--	20316	--	01
17	Label (Standard)	00002	--	01	--	--	--	00002	--	01
18	Valve seat (dia 4)	20118	--	01	--	--	--	20318	--	01
19	Poppet (dia 4)	20119	--	01	--	--	--	20319	--	01
20	Body (Threaded) - 700 bar	20120	--	01	--	--	--	20320	--	01
21	Body (Subplate) - 700 bar	20121	--	01	--	--	--	20321	--	01
22	--	--	--	--	--	--	--	--	--	--
23	--	--	--	--	--	--	--	--	--	--
24	--	--	--	--	--	--	--	--	--	--
25	--	--	--	--	--	--	--	--	--	--
* 26	O'ring (Nitrile)	20126	17 id x 1.8 csd	01	20226	23.5 id x 1.8 csd	01	20326	28.2 id x 2.65 csd	01
* 27	O'ring (Nitrile)	20127	11.3 id x 2.4 csd	01	20227	17 id x 2.5 csd	01	20327	--	01
* 28	O'ring (Nitrile)	20128	22 id x 1.8 csd	01	20228	28.3 id x 1.78 csd	01	20328	34.5 id x 2.65 csd	01
* 29	Backup ring (Teflon)	20129	22.3 x 24.98 x 1.2 th.	02	20229	31.98 x 29.3 x 1.2 th.	02	20329	31.98 x 29.3 x 1.2 th.	02
* 30	O'ring (Nitrile)	20130	7 id x 1.5 csd	02	20230	12 id x 2 csd	02	20330	23 id x 2.5 csd	02
* 31	O'ring (Nitrile)	20131	7.5 id x 1.8 csd	02	20231	--	--	20331	--	--
32	Grub screw	00045	M6 x 1, 8 L	02	00042	M8 x 8 L	02	00042	M8 x 8 L	02
33	Circlip (IS 3075-1965)	00060	'C' type, dia 6 nominal, (External)	01	20233	'C' type,dia 8 Nominal, (External)	01	20333	'C' type,dia 8 Nominal, (External)	01
34	Elastomeric plug	00202	G1/4	01	00204	G1/2	01	00202	G1 (Threaded)	01
35	Dowel pin	00036	Dia 3 x 8 L	01	--	--	--	--	--	--
# 36	Spring 25 bar	20136	Code 20136	01	20236	Code 20236	01	20336	Code 20336	01
# 37	Spring 50 bar	20137	--" -- 20137	01	20237	--" -- 20237	01	20337	--" -- 20337	01
# 38	Spring 100 bar	20138	--" -- 20138	01	20238	--" -- 20238	01	20338	--" -- 20338	01
# 39	Spring 200 bar	20139	--" -- 20139	01	20239	--" -- 20239	01	20339	--" -- 20339	01
# 40	Spring 315 bar	20140	--" -- 20140	01	20240	--" -- 20240	01	20340	--" -- 20340	01
# 41	Spring 400 bar	20141	--" -- 20141	01	20241	--" -- 20241	01	20341	--" -- 20341	01
42	Rivet (Type ' U ')	00001	2 x 4.5 M (Nettlefold)	02	00001	2 x 4.5 M (Nettlefold)	02	00001	2 x 4.5 M (Nettlefold)	02
43	Rivet (Type ' U ')	00001	--" --	01	00001	--" --	01	00001	--" --	01
44	Spring retainer	--	--	--	--	--	--	20344	--	--
45	Circlip (IS 3075 - 1965)	--	--	--	--	--	--	20345	'C' type,dia 8 Nominal, (External)	01
# 46	O'ring	--	--	--	--	--	--	20346	14 id x 1.8 csd	01
# 47	O'ring	--	--	--	--	--	--	20347	32 id x 2.3 csd	01

Note : * Recommended seal kit. * & # Recommended spare kit.
While ordering the individual spares / spare kit / seal kit, give part no. and complete details of model code as on the label.